



BY JOHNSON CONTROLS



***Model YCUL Air-Cooled Scroll Compressor Condensing Units
Style E***



50 AND 60HZ
40 – 80 TON
140 – 281 KW
R-410A



Table of Contents

<i>FORM 150.68-EG1 (509)</i>	1
<i>Introduction</i>	3
<i>Specification</i>	4
<i>MicroComputer Control Center</i>	5
<i>Options and Accessories</i>	7
<i>Unit Nomenclature</i>	9
<i>Selection Data</i>	10
<i>Ratings - R-410A (60Hz - English Units)</i>	14
<i>Ratings - R-410A (50Hz - English Units)</i>	20
<i>Physical Data - English & SI</i>	26
<i>Dimensions</i>	28
<i>Isolator Selections</i>	30
<i>Electrical Data - 50 & 60Hz</i>	33
<i>Electrical Notes</i>	35
<i>Circuit Breaker Calculations</i>	36
<i>Application Data</i>	37
<i>Guide Specifications</i>	38

Model YCUL Air-Cooled Scroll Compressor Condensing Units Style E



YORK Air-Cooled Scroll Condensing Units are the perfect refrigeration components for all air conditioning applications that use DX central station air handling. They are designed for outdoor (roof or ground level) installation. Each unit includes hermetic scroll compressors, an air cooled condenser, and a weather resistant microprocessor control center, all mounted on a formed steel base.

Specification

GENERAL

The 40 - 80 Ton (140 - 281 kW) YCUL models are shipped complete from the factory ready for installation and use.

The unit is pressure-tested, evacuated and given a nitrogen holding charge and includes an initial oil charge (R-410A refrigerant supplied by others). After assembly, a operational test is performed to assure that each control device operates correctly.

The unit structure is heavy-gauge, galvanized steel. This galvanized steel is coated with baked-on powder paint, which, when subjected to ASTM B117 1000 hour, salt spray testing, yields a minimum ASTM 1654 rating of "6". Units are designed in accordance with NFPA 70 (National Electric Code), ASHRAE/ANSI 15 Safety code for mechanical refrigeration, and are cETL listed. All units are produced at an ISO 9000-registered facility.

COMPRESSORS

The chiller has suction-gas cooled, hermetic, scroll compressors. The YCUL compressors incorporate a scroll design that is compliant in both the axial and radial direction. All rotating parts are statically and dynamically balanced.

A large internal volume and oil reservoir provides greater liquid tolerance. Compressor crankcase heaters are also included for extra protection against liquid migration.

CONDENSER

Coils – Fin and tube condenser coils of seamless, internally-enhanced, high-condensing-coefficient, corrosion resistant copper tubes are arranged in staggered rows, mechanically expanded into aluminum fins. Integral subcooling is included. The design working pressure of the coil is 650 PSIG (45 barg).

Low Sound Fans – The condenser fans are composed of corrosion resistant aluminum hub and composite blades molded into a low noise airfoil section. They are designed for maximum efficiency and are statically and dynamically balanced for vibration-free operation. They are directly driven, and positioned for vertical air discharge. The fan guards are constructed of heavy-gauge, rust-resistant, PVC (polyvinyl chloride)-coated steel wire.

Motors – The fan motors are Totally Enclosed Air-Over, squirrel-cage type, current protected. They feature ball bearings that are double-sealed and permanently lubricated.

MicroComputer Control Center

All controls are contained in a NEMA 3R/12 cabinet with hinged outer door and includes:

Liquid Crystal Display with Light Emitting Diode backlighting for outdoor viewing:

- Two display lines
- Twenty characters per line

Color coded 12-button non-tactile keypad with sections for:

DISPLAY/PRINT of typical information:

- Suction temperatures (optional)
- Ambient temperature
- System pressures (each circuit)
- Operating hours and starts (each compressor)
- Print calls up to the liquid crystal display:
- Operating data for the systems
- History of fault shutdown data for up to the last six fault shutdown conditions
- An RS-232 port, in conjunction with this press-to-print button, is provided to permit the capability of hard copy print-outs via a separate printer (by others).

ENTRY section to:

- **ENTER** setpoints or modify system values **SETPOINTS** updating can be performed to:
 - Suction pressure setting
 - Suction pressure control zone
 - Remote reset temperature range
 - Set daily schedule/holiday for start/stop
 - Manual override for servicing
 - Low and high ambient cutouts
 - Number of compressors
 - Low suction pressure cutout
 - High discharge pressure cutout
 - Anti-recycle timer (compressor start cycle time)
 - Anti-coincident timer (delay compressor starts) **UNIT** section to:
 - Set clock
 - Set options
 - Set unit option

Set unit control for Discharge Air Temperature Control or for Suction Pressure Control (requires Suction Pressure Transducers – standard.

UNIT ON/OFF switch

The microprocessor control center is capable of displaying the following:

- Suction temperatures (optional)
- Low ambient temperature cutout setting
- Outdoor air temperature
- English or Metric data
- Suction pressure cutout setting
- Each system suction pressure
- System discharge pressure
- Discharge Air Temperature Reset via a YORK ISN DDC or Building Automation System (by others) via:
 - a pulse width modulated (PWM) input as standard
 - a 4-20 milliamp or 0 -10 VDC input, or contact closure with the optional B.A.S. interface option
- Anti-recycle timer status for each system
- Anti-coincident system start timer condition
- Compressor run status
- No cooling load condition
- Day, date and time
- Daily start/stop times
- Holiday status
- Automatic or manual system lead/lag control (Discharge Air Temperature control only)
- Automatic lead/lag of compressors within a system
- Compressor starts & operating hours (each compressor)
- Status of hot gas valves, and fan operation
- Run permissive status
- Number of compressors running
- Liquid solenoid valve status
- Load & unload timer status

Provisions are included for: pumpdown at shutdown; optional remote discharge air temperature reset and two steps of demand load limiting from an external building automation system. Unit alarm contacts are standard.

The operating program is stored in non-volatile memory (EPROM) to eliminate chiller failure due to AC powered failure/battery discharge. Programmed setpoints are retained in lithium battery-backed RTC memory for 5 years minimum.

* Intensity of Protection European Standard

MicroComputer Control Center - continued

COMMUNICATIONS

- Native communication capability for BACnet (MS/TP) and Modbus
- Optional communication available for N2 and LON via eLink option

POWER PANEL

Each panel contains:

- Compressor power terminals

- Compressor motor starting contactors per I.E.C.*
- Control power terminals to accept incoming for 115-1-60 control power
- Fan contactors & overload current protection

The power wiring is routed through liquid-tight conduit to the compressors and fans.

** International Electrotechnical Commission

Options and Accessories

ELECTRICAL OPTIONS:

COMPRESSOR POWER CONNECTIONS – Single-point terminal block connection(s) are provided as standard. The following power connections are available as options. (See electrical data for specific voltage and options availability.) **(Factory-Mounted.)**

SINGLE-POINT SUPPLY TERMINAL BLOCK – (standard on YCUL models). Includes enclosure, terminal-block and interconnecting wiring to the compressors. Separate external protection must be supplied, by others, in the incoming compressor-power wiring. (Do not include this option if either the SinglePoint NonFused Disconnect Switch or Single-Point Circuit Breaker options have been included.)

SINGLE-POINT NON-FUSED DISCONNECT SWITCH – Unit-mounted disconnect switch with external, lockable handle (in compliance with Article 440-14 of N.E.C.), can be supplied to isolate the unit power voltage for servicing. Separate external fusing must be supplied, by others in the power wiring, which must comply with the National Electrical Code and/or local codes.

SINGLE-POINT CIRCUIT BREAKER – A unit mounted circuit breaker with external, lockable handle (in compliance with N.E.C. Article 440-14), can be supplied to isolate the power voltage for servicing. (This option includes the Single-Point Power connection.)

CONTROL TRANSFORMER – Converts unit power voltage to 115-1-60 (0.5 or 1.0 KVA capacity). Factory mounting includes primary and secondary wiring between the transformer and the control panel. **(Factory-Mounted.)**

POWER FACTOR CORRECTION CAPACITORS – Will correct unit compressor power factors to a 0.90-0.95. **(Factory-Mounted.)**

CONTROL OPTIONS:

AMBIENT KIT (LOW) – Units will operate to 25°F (-4°C). This accessory includes all necessary components to permit chiller operation to 0°F (-18°C). (This option includes the Discharge Pressure Transducer / Readout Capability option.) For proper head pressure control in applications below 25°F (-4°C), where wind gusts may exceed five mph, it is recommended that Optional Condenser Louvered Enclosure Panels also be included. **(Factory-Mounted.)**

AMBIENT KIT (HIGH) – Required if units are to operate when the ambient temperature is above 110°F (43°C). Includes discharge pressure transducers. (This option includes the Discharge Pressure Transducer / Readout-Capability option.) **(Factory-Mounted.)**

BUILDING AUTOMATION SYSTEM INTERFACE – The factory addition of a Printed Circuit Board to accept a 4-20 milliamp, 0-10VDC or contact closure input to reset the leaving chiller liquid temperature from a Building Automation System. (Only one of following options can be offered on a unit at a time: BAS, Remote Control Panel or Multi-unit Sequence Control.) **(Factory-Mounted.)** (The standard unit capabilities include remote startstop, remote water temperature reset via a PWM input signal or up to two steps of demand (load) limiting depending on model. The standard control panel can be directly connected to a Johnson Controls Building Automated System via the standard onboard RS485 communication port.)

LANGUAGE LCD AND KEYPAD DISPLAY – Spanish, French, and German unit LCD controls and keypad display available. Standard language is English.

DISCHARGE PRESSURE TRANSDUCERS AND READ-OUT CAPABILITY – The addition of pressure transducers allows models to sense and display discharge pressure. This is recommended for brine chilling applications. (This option is included with either the low or high ambient kits.) **(Factory-Mounted.)**

SUCTION PRESSURE TRANSDUCERS – Permits unit to sense and display suction pressure. This capability is standard on YCUL models.

MOTOR CURRENT MODULE – Capable of monitoring compressor motor current. Provides extra protection against compressor reverse rotation, phase-loss and phase imbalance. Option consists of one module per electrical system. **(Factory-Mounted.)**

OPTIVIEW REMOTE CONTROL PANEL – Graphical interface panel to remotely control and monitor up to 8 different units. (Refer to form 201.18-SG4 for detailed information)

MULTI-UNIT SEQUENCING – A separate sequencing control center is provided to handle sequencing control of up to eight chillers in parallel based on mixed liquid temperature (interconnecting wiring by others). (Only one of following options can be offered on a unit at a time: BAS, Remote Control Panel or Multi-Unit Sequence Control.) **(Factory-Mounted.)**

Options and Accessories - continued

COMPRESSOR AND PIPING OPTIONS:

CHICAGO CODE RELIEF VALVES – Unit will be provided with relief valves to meet Chicago code requirements. **(Factory-Mounted)**

SERVICE ISOLATION VALVE – Service isolation valves are standard to unit. This includes a system high pressure relief valve or internal compressor relief mechanism in compliance with ASHRAE 15. **(Factory-Mounted)**

HOT GAS BY-PASS – Permits continuous, stable operation at capacities below the minimum step of compressor unloading to as low as 5% capacity (depending on both the unit and operating conditions) by introducing an artificial load on the cooler. Hot gas by-pass is installed on only refrigerant system #1 on two-circuited units. **(Factory-Mounted)**

CONDENSER AND CABINET OPTIONS:

Condenser coil protection against corrosive environments is available by choosing any of the following options. For additional application recommendations, refer to Form 150.12-ES1. **(Factory-Mounted.)**

PRE-COATED FIN CONDENSER COILS – The unit's coils are constructed with epoxy coated aluminum fins. This can provide corrosion resistance comparable to copper-fin coils in typical seashore locations. Either these or the post-coated coils (below), are recommended for units being installed at the seashore or where salt spray may hit the unit.

POST-COATED DIPPED CONDENSER COILS – The unit's coils are constructed with dipped-cured condenser coils. This is the choice for corrosive applications (with the exception of strong alkalies, oxidizers and wet bromine, chlorine and fluorine in concentrations greater than 100 ppm).

COPPER FIN CONDENSER COILS – The unit's coils are constructed with copper fins. (This is not recommended for units in areas where they may be exposed to acid rain.)

ENCLOSURE PANELS (UNIT) – Tamperproof enclosure panels prevent unauthorized access to units. Enclosure panels can provide an aesthetically pleasing alternative to expensive fencing. Additionally, for proper head pressure control, Johnson Controls recommends the use of :

LOUVERED PANELS (FULL UNIT) – Louvered panels surround the front, back, and sides of the unit. They prevent unauthorized access and visually screen unit components. Unrestricted air flow is permitted through generously sized louvered openings. This option is applicable for any outdoor design ambient temperature up to 115°F (46°C). **(Factory-Mounted.)**

SOUND ATTENUATION – One or both of the following sound attenuation options are recommended for residential or other similar sound-sensitive locations. Louvered Panels can be ordered for winter applications where wind gusts may exceed five miles per hour. The following types of enclosure options are available:

COMPRESSOR ACOUSTIC SOUND BLANKET – Each compressor is individually enclosed by an acoustic sound blanket. The sound blankets are made with one layer of acoustical absorbent textile fiber of 5/8" (15mm) thickness; one layer of anti-vibrating heavy material thickness of 1/8" (3mm). Both are closed by two sheets of welded PVC, reinforced for temperature and UV resistance. **(Factory-Mounted.)**

ULTRA QUIET FANS – Lower RPM, 8-pole fan motors are used with steeper-pitch fans. **(Factory-Mounted.)**

VIBRATION ISOLATORS – Level adjusting, spring type 1" (25.4mm) or seismic deflection or neoprene pad isolators for mounting under unit base rails. **(Field-Mounted.)**

Unit Nomenclature

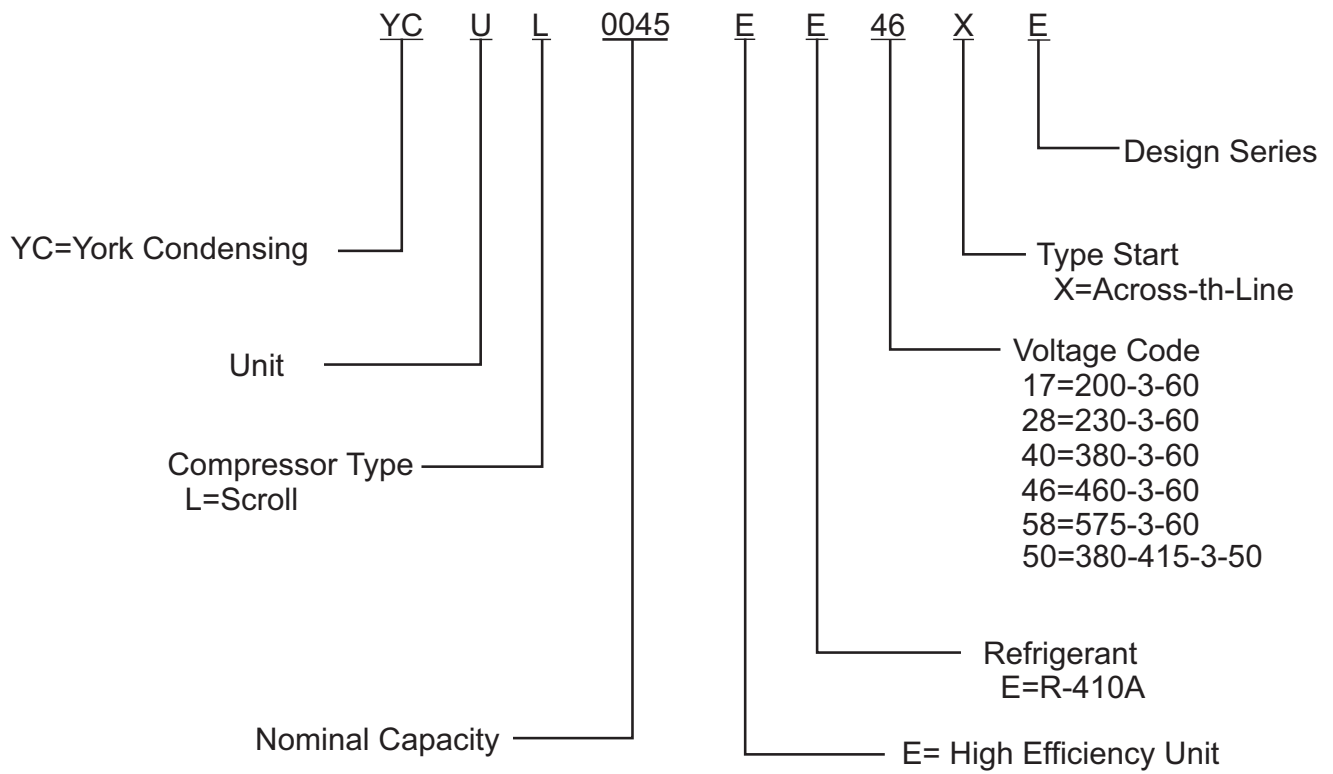

Selection Data

The ratings shown on pages 14 through 25 are based on unit operation in a well designed and properly piped system.

SELECTION RULES

1. Capabilities are based on Refrigerant R-410A.
2. Ratings may be interpolated, but must not be extrapolated.
3. Ratings shown are at saturated suction temperatures corresponding to pressures at the compressor. In actual practice, suction line pressure drop has the effect of reducing compressor capacity, forcing the compressor to operate at a lower suction pressure to maintain the desired evaporator temperature.

For normal air conditioning applications, size the suction line for a pressure drop of 3 PSI, corresponding to 2°F, for R-410A refrigerant. Thus, the evaporator temperature will be approximately 2°F higher than the compressor suction temperature. Line loss must be taken into consideration when selecting the evaporator.

SELECTION PROCEDURE

The air-cooled condensing unit may be selected from the Ratings on pages 14 through 25, if the ambient air temperature at the condenser and the saturated suction temperature at the compressor are known. The ambient air temperature is a known design parameter, but the suction temperature at the compressor, in many cases, is known only within certain allowable limits. The actual compressor operating suction temperature and the overall performance of the system will depend directly upon the choice of the evaporator. Starting with a preliminary evaporator selection at a nominal evaporator temperature and using data supplied by the evaporator manufacturer, enter the ratings tables and select a unit to meet the

required cooling load at a suction temperature at least 2°F below the evaporator temperature. The 2°F allows for normal suction line loss.

If more accurate selection is required, the evaporator capacity should be plotted against the condensing unit capacity to determine the balanced system performance. Again, it is necessary to factor in the suction line loss.

After the system balance point has been determined, the compressor KW input may be interpolated from the ratings tables.

SAMPLE SELECTION

Select an R-410A Air-Cooled Condensing Unit with a matched central station air handling unit having the following operating conditions:

Design Conditions

1. An air handling unit with two large DX coils (one per circuit) having a total cooling load of 600 MBH (50 tons).
2. The coil suction temperature required 45°F.
3. The design outdoor ambient temperature is 95°F.
4. The power supply is 460V/3Ø/60 hz.

Selection

1. Enter the **YCUL0055EE** Rating Table (page 12).
2. The model **YCUL0055EE** will provide 51.6 tons with 48.9 compressor KW input at 95°F ambient air and 45°F suction pressure.
3. Calculate the compressor Kw input for the specific design conditions of 50 tons and 95°F ambient air.

$$KW = \frac{50}{51.6 \text{ Kw}} \times 48.9 \text{ Kw} = 47.4 \text{ Kw}$$

The **YCUL0055EE** is the suitable selection for the design capacity.

Selection Data - continued

REFRIGERANT PIPING

General – When the unit has been located in its final position, the unit piping may be connected. Normal installation precautions should be observed in order to receive maximum operating efficiencies. System piping should conform to the York DX piping guide form 050.40-ES2 or ASHRAE refrigeration handbook guidelines. All piping design and installation is the responsibility of the user.

JOHNSON CONTROLS ASSUMES NO WARRANTY RESPONSIBILITY FOR SYSTEM OPERATION OR FAILURES DUE TO IMPROPER PIPING OR PIPING DESIGN.

Filter driers and sight glasses are shipped loose for field installation on each refrigerant circuit. Field refrigerant piping can be connected to the condensing unit.

All expansion valves, liquid line solenoid valves, refrigerant and refrigerant piping are supplied and installed by others.

Table 4 lists refrigerant line connections sizes per unit model number.

REFRIGERANT LINE SIZING

Refrigerant piping systems must be designed to provide practical line sizes without excessive pressure drops, prevent compressor oil from being “trapped” in the refrigerant piping, and ensure proper flow of liquid refrigerant to the thermal expansion valve. Considerations should be given to:

- 1) Suction line pressure drop due to refrigerant flow.
- 2) Suction line refrigerant velocity for oil return.
- 3) Liquid line pressure drop due to refrigerant flow.
- 4) Liquid line pressure drop (or gain) due to vertical rise of the liquid line.

Table 5 provides the pressure drops for given pipe sizes for both liquid and suction lines. The pressure drops given are per 100 equivalent ft. (30.5 m) of refrigerant piping. These friction losses do not include any allowances for strainer, filter drier, solenoid valve, isolation valve or fittings

Nominal pressure drop for solenoids, sight glass, and driers are shown in Table 2.

Table 1 includes approximate equivalent lengths for copper fittings.

To ensure a solid column of liquid refrigerant to the expansion valve, the total liquid line pressure drop should never

exceed 50 psi (3.4 bar). Refrigerant vapor in the liquid line will measurably reduce valve capacity and poor system performance can be expected.

To allow adequate oil return to the compressor, suction risers should be sized for a minimum of 1000 FPM (5.08 m/s) while the system is operating at minimum capacity to ensure oil return up the suction riser. Refer to Table 5 under column labeled Nominal Tons (KW) Unloaded.

Evaporator Below Condensing Unit

On a system where the evaporator is located below the condensing unit, the suction line must be sized for both pressure drop and oil return. In some cases a double suction riser must be installed to ensure reliable oil return at reduced loads. Table 3 indicates when a double suction riser should be used for listed pipe sizes to provide adequate oil return at reduced loads. The calculated information was based on maintaining a minimum of 1000 fpm (5.08 m/s) refrigerant vapor velocity.

Condenser Below Evaporator

When the condensing unit is located below the evaporator, the liquid line must be designed for both friction loss and static head loss due the vertical rise. The value of static head loss of 5 PSI/ft.(3.4 kPa/30 cm) must be added to the friction loss pressure drop in addition to all pressure drops due to driers, valves, etc.

OIL TRAPS

All horizontal suction lines should be pitched at least 1/4" per foot (2 cm/m) in the direction of the refrigerant flow to aid in the return of oil to the compressor. All suction lines with a vertical rise exceeding 3 feet (.91 meters) should have a “P” trap at the bottom and top of the riser. Suction lines with a vertical rise exceeding 25 feet (7.6 meters) should be trapped every 15 feet (4.6 meters).

REFRIGERANT CHARGE

The condensing unit is charged with a dry nitrogen holding charge. The remaining operating charge for the condensing unit, evaporator coil, and refrigerant piping must be weighed in after all refrigerant piping is installed, leak checked, and evacuated. Final adjustment of refrigerant charge should be verified by subcooling values (refer to section on Pre-Startup for checking subcooling).

REFRIGERANT PIPING REFERENCE

For more details, refer to ASHRAE Refrigeration Handbook, Chapter 2.

Selection Data - continued

TABLE 1 - FITTING EQUIVALENT LENGTHS

YCUL	Short Radius Ell	Long Radius Ell
3/4" (19mm)	6.5ft. (2m)	4.5 ft.(1.4m)
7/8" (22mm)	7.8 ft. (2.4m)	5.3 ft (1.6m)
1-1/8" (29mm)	2.7ft. (.8m)	1.9 ft. (.6m)
1-3/8" (35mm)	3.2 ft. (1m)	2.2 ft. (.7m)
1-5/8" (41mm)	3.8 ft. (1.2m)	2.6 ft. (.8m)
2-1/8" (54mm)	5.2 ft. (1.6m)	3.4 ft. (1m)
2-5/8" (67mm)	6.5 ft (20m)	4.2 ft. (1.3m)

*Copper Fitting Equivalent Lengths

TABLE 2 – MISCELLANEOUS LIQUID LINE PRESSURE DROPS

Solenoid Valve	2-3 PSI (13.8 - 20.7kPa)
Filter/Drier	2-3 PSI (13.8 - 20.7kPa)
Sight Glass	0.5PSI (3.4 kPa)

TABLE 3 – REFRIGERATION PIPING CHARGES

R-410a Suct @ 36 deg Liq @ 105 deg					
SUCTION LINES					
Size	ID	Cu ft	Density Lb/Cu Ft	Oz./Ft.	Grams/30 Cm
1-3/8	1.3	0.0	2.1	0.3	8.1
1-5/8	1.5	0.0	2.1	0.4	11.5
2-1/8	2.0	0.0	2.1	0.7	20.0
2-5/8	2.5	0.0	2.1	1.1	30.9
LIQUID LINES					
3/4	0.7	0.0	60.9	2.4	66.8
7/8	0.8	0.0	60.9	3.3	92.8
1-1/8	1.0	0.0	60.9	5.6	158.3
1-3/8	1.3	0.0	60.9	8.5	241.1

TABLE 4 – REFRIGERANT LINE CONNECTIONS

MODEL NUMBER	TONS	SYSTEM NUMBER	REFRIGERANT LINE CONNECTION		SUCTION LINE	LIQUID LINE	
			SUCTION	LIQUID	COPPER TYPE L INCHES OD	NOMINAL TONS UNLOADED	COPPER TYPE L INCHES OD
0045EE	41.6	1	2.1	1.1	2-1/8	10.4	1-1/8
		2	2.1	1.1	2-1/8	10.4	1-1/8
0051EE	44.1	1	2.1	1.1	2-1/8	11.7	1-1/8
		2	2.1	1.1	2-1/8	10.4	1-1/8
0055EE	51.6	1	2.1	1.1	2-1/8	12.9	1-1/8
		2	2.1	1.1	2-1/8	12.9	1-1/8
0065EE	59.5	1	2.1	1.1	2-1/8	14.9	1-1/8
		2	2.1	1.1	2-1/8	14.9	1-1/8
0072EE	73.5	1	2.3	1.1	2-3/8	21.9	1-1/8
		2	2.1	1.1	2-1/8	14.9	1-1/8

Refrigerant Piping Notes

1. Based on R-410A at the nominal capacity of the unit or system, an ambient temperature of 95°F (35°C) and a suction temperature of 45°F (7.2°C).
2. Suction line sizes were calculated based on a nominal maximum pressure drop to 3 PSI/100 ft. (20.7 kPa/30.5 m). When calculating suction line pressure drop for a specific application, it should be noted that system capacity decreases as suction line pressure drop increases.
4. Nominal Tons (KW) Unloaded is based on one compressor (per system) operating at design conditions.
5. Based on minimum compressor staging for the given pipe size, a double suction riser should be used to ensure proper oil return to the compressor on all vertical suction risers. Oil returning up the riser moves up the inner surface of the pipe and depends on the mass velocity of the refrigerant vapor at the wall surface to move the oil up the vertical rise.
6. Hot gas bypass lines are typically 7/8" for lines up to 40 feet and 1-1/8" for lines over 40 feet in length (12 meters). The field connections sizes are 7/8" for the optional factory mounted hot gas bypass valve. Note: Hot gas bypass is only available for refrigerant system number 1.
7. For more information, please refer to either the York DX Piping Guide (Form 050.40-ES2) or the ASHRAE Refrigeration Handbook.

Ratings - R-410A (60Hz - English Units)

MODEL: YCUL0045EE

AIR TEMPERATURE ON - CONDENSER (°F)

SST (°F)	75.0			80.0			85.0			90.0			95.0		
	TONS	KW	EER	TONS	KW	EER	TONS	KW	EER	TONS	KW	EER	TONS	KW	EER
35.0	39.4	30.8	13.0	38.3	32.4	12.1	37.1	34.2	11.2	35.9	36.2	10.3	34.7	38.4	9.4
37.0	40.8	31.0	13.4	39.7	32.6	12.5	38.5	34.4	11.6	37.3	36.4	10.7	36.0	38.6	9.8
39.0	42.2	31.2	13.8	41.1	32.8	12.8	39.9	34.6	11.9	38.7	36.6	11.0	37.3	38.8	10.1
41.0	43.6	31.4	14.1	42.5	33.0	13.2	41.3	34.8	12.3	40.1	36.8	11.3	38.7	39.1	10.4
43.0	45.1	31.6	14.5	44.0	33.2	13.6	42.8	35.0	12.6	41.5	37.1	11.7	40.1	39.3	10.7
45.0	46.6	31.8	14.9	45.5	33.4	14.0	44.2	35.3	13.0	42.9	37.3	12.0	41.6	39.5	11.1
47.0	48.1	32.0	15.3	47.0	33.7	14.4	45.7	35.5	13.4	44.4	37.6	12.4	43.0	39.8	11.4
49.0	49.7	32.2	15.8	48.5	33.9	14.7	47.3	35.8	13.7	45.9	37.8	12.7	44.5	40.0	11.7
51.0	51.2	32.4	16.2	50.1	34.1	15.1	48.8	36.0	14.1	47.5	38.1	13.0	46.0	40.3	12.0
53.0	52.9	32.7	16.6	51.7	34.4	15.5	50.4	36.3	14.4	49.0	38.3	13.4	47.5	40.6	12.3
55.0	54.5	32.9	17.0	53.3	34.6	15.9	52.0	36.5	14.8	50.6	38.6	13.7	49.1	40.9	12.7

MODEL: YCUL0051EE

AIR TEMPERATURE ON - CONDENSER (°F)

SST (°F)	75.0			80.0			85.0			90.0			95.0		
	TONS	KW	EER	TONS	KW	EER	TONS	KW	EER	TONS	KW	EER	TONS	KW	EER
35.0	42.0	33.7	12.8	40.8	35.5	11.9	39.5	37.5	11.0	38.2	39.7	10.1	36.9	42.1	9.3
37.0	43.5	34.0	13.2	42.2	35.8	12.2	41.0	37.8	11.3	39.6	39.9	10.4	38.3	42.3	9.6
39.0	45.0	34.2	13.6	43.7	36.0	12.6	42.4	38.0	11.7	41.1	40.2	10.8	39.7	42.6	9.9
41.0	46.6	34.5	13.9	45.3	36.3	13.0	43.9	38.3	12.0	42.6	40.5	11.1	41.1	42.9	10.2
43.0	48.2	34.8	14.3	46.8	36.6	13.3	45.5	38.6	12.4	44.1	40.8	11.4	42.6	43.1	10.5
45.0	49.8	35.0	14.7	48.4	36.9	13.7	47.1	38.9	12.7	45.6	41.1	11.7	44.1	43.4	10.8
47.0	51.4	35.3	15.1	50.1	37.2	14.0	48.7	39.2	13.0	47.2	41.4	12.1	45.6	43.7	11.1
49.0	53.1	35.6	15.5	51.7	37.5	14.4	50.3	39.5	13.4	48.8	41.7	12.4	47.2	44.1	11.4
51.0	54.9	35.9	15.8	53.4	37.8	14.8	51.9	39.8	13.7	50.4	42.0	12.7	48.8	44.4	11.7
53.0	56.6	36.2	16.2	55.2	38.1	15.1	53.6	40.2	14.1	52.0	42.4	13.0	50.4	44.7	12.0
55.0	58.4	36.6	16.6	56.9	38.4	15.5	55.4	40.5	14.4	53.7	42.7	13.3	52.1	45.1	12.3

indicates package unloaded due to high pressure conditions

? indicates no rating available at this condition

MODEL: YCUL0045EE**AIR TEMPERATURE ON - CONDENSER (°F)**

SST (°F)	100.0			105.0			110.0			115.0		
	TONS	KW	EER	TONS	KW	EER	TONS	KW	EER	TONS	KW	EER
35.0	33.3	40.9	8.6	31.9	43.6	7.8	30.5	46.5	7.0	29.1	49.6	6.3
37.0	34.6	41.1	8.9	33.2	43.7	8.1	31.8	46.6	7.3	30.3	49.7	6.6
39.0	36.0	41.3	9.2	34.5	43.9	8.4	33.0	46.8	7.6	31.5	49.9	6.8
41.0	37.3	41.5	9.5	35.8	44.1	8.6	34.3	47.0	7.8	32.8	50.1	7.1
43.0	38.7	41.7	9.8	37.2	44.4	8.9	35.6	47.2	8.1	34.0	50.2	7.3
45.0	40.1	42.0	10.1	38.6	44.6	9.2	37.0	47.4	8.4	35.3	50.5	7.6
47.0	41.5	42.2	10.4	40.0	44.8	9.5	38.4	47.7	8.6	36.7	50.7	7.8
49.0	43.0	42.5	10.7	41.4	45.1	9.8	39.7	47.9	8.9	38.0	50.9	8.1
51.0	44.5	42.8	11.0	42.8	45.4	10.1	41.2	48.2	9.2	39.4	51.2	8.3
53.0	46.0	43.1	11.3	44.3	45.7	10.4	42.6	48.5	9.5	40.8	51.5	8.6
55.0	47.5	43.4	11.6	45.8	46.0	10.7	44.1	48.8	9.7	42.2	51.8	8.8

MODEL: YCUL0051EE**AIR TEMPERATURE ON - CONDENSER (°F)**

SST (°F)	100.0			105.0			110.0			115.0		
	TONS	KW	EER	TONS	KW	EER	TONS	KW	EER	TONS	KW	EER
35.0	35.5	44.7	8.5	34.0	47.5	7.7	32.6	50.5	7.0	31.0	53.7	6.3
37.0	36.8	44.9	8.8	35.4	47.7	8.0	33.9	50.7	7.2	32.3	53.9	6.5
39.0	38.2	45.2	9.0	36.7	47.9	8.2	35.2	50.9	7.5	33.6	54.1	6.7
41.0	39.6	45.4	9.3	38.1	48.2	8.5	36.5	51.1	7.7	34.9	54.3	7.0
43.0	41.1	45.7	9.6	39.5	48.5	8.8	37.9	51.4	8.0	36.2	54.6	7.2
45.0	42.5	46.0	9.9	40.9	48.7	9.0	39.3	51.7	8.2	37.6	54.8	7.5
47.0	44.0	46.3	10.2	42.4	49.1	9.3	40.7	52.0	8.5	39.0	55.1	7.7
49.0	45.6	46.6	10.5	43.9	49.4	9.6	42.2	52.3	8.7	40.4	55.4	7.9
51.0	47.1	47.0	10.8	45.4	49.7	9.9	43.6	52.6	9.0	41.8	55.8	8.2
53.0	48.7	47.3	11.0	46.9	50.0	10.1	45.1	53.0	9.2	43.3	56.1	8.4
55.0	50.3	47.7	11.3	48.5	50.4	10.4	46.7	53.3	9.5	44.7	56.4	8.7

indicates package unloaded due to high pressure conditions

? indicates no rating available at this condition

Ratings - R-410A (60Hz - English Units) - Cont.

MODEL: YCUL0055EE

AIR TEMPERATURE ON - CONDENSER (°F)

SST (°F)	75.0			80.0			85.0			90.0			95.0		
	TONS	KW	EER	TONS	KW	EER	TONS	KW	EER	TONS	KW	EER	TONS	KW	EER
35.0	48.8	38.1	13.1	47.5	40.1	12.2	46.1	42.3	11.3	44.7	44.6	10.5	43.3	47.1	9.7
37.0	50.6	38.4	13.4	49.2	40.5	12.5	47.8	42.6	11.6	46.3	44.9	10.8	44.9	47.4	9.9
39.0	52.5	38.8	13.8	51.0	40.8	12.9	49.5	43.0	12.0	48.0	45.3	11.1	46.5	47.8	10.2
41.0	54.4	39.2	14.2	52.8	41.2	13.2	51.3	43.4	12.3	49.7	45.7	11.4	48.2	48.1	10.5
43.0	56.3	39.6	14.6	54.7	41.6	13.6	53.1	43.8	12.6	51.5	46.1	11.7	49.9	48.5	10.8
45.0	58.3	40.0	15.0	56.6	42.0	13.9	55.0	44.2	13.0	53.3	46.5	12.0	51.6	48.9	11.1
47.0	60.3	40.5	15.3	58.6	42.5	14.3	56.9	44.6	13.3	55.1	46.9	12.3	53.4	49.3	11.4
49.0	62.4	41.0	15.7	60.6	42.9	14.7	58.8	45.0	13.6	57.0	47.3	12.7	55.2	49.8	11.7
51.0	64.5	41.4	16.1	62.7	43.4	15.0	60.8	45.5	14.0	59.0	47.8	13.0	57.1	50.2	12.0
53.0	66.7	41.9	16.5	64.8	43.9	15.4	62.9	46.0	14.3	60.9	48.3	13.3	59.0	50.7	12.3
55.0	68.9	42.5	16.8	67.0	44.4	15.7	65.0	46.5	14.7	63.0	48.8	13.6	60.9	51.2	12.6

MODEL: YCUL0065EE

AIR TEMPERATURE ON - CONDENSER (°F)

SST (°F)	75.0			80.0			85.0			90.0			95.0		
	TONS	KW	EER	TONS	KW	EER	TONS	KW	EER	TONS	KW	EER	TONS	KW	EER
35.0	56.5	46.4	12.8	55.0	48.7	11.9	53.4	51.2	11.1	51.8	53.8	10.3	50.1	56.7	9.5
37.0	58.5	46.9	13.1	57.0	49.2	12.2	55.4	51.6	11.4	53.7	54.3	10.6	51.9	57.2	9.7
39.0	60.6	47.4	13.4	59.0	49.7	12.5	57.3	52.2	11.7	55.6	54.8	10.8	53.7	57.7	10.0
41.0	62.7	48.0	13.7	61.0	50.2	12.9	59.3	52.7	12.0	57.5	55.4	11.1	55.6	58.2	10.3
43.0	64.8	48.6	14.1	63.1	50.8	13.2	61.3	53.3	12.3	59.5	55.9	11.4	57.5	58.8	10.5
45.0	66.9	49.2	14.4	65.2	51.4	13.5	63.4	53.9	12.5	61.5	56.5	11.7	59.5	59.4	10.8
47.0	69.1	49.8	14.7	67.3	52.1	13.7	65.5	54.5	12.8	63.5	57.2	11.9	61.5	60.0	11.1
49.0	71.4	50.5	15.0	69.5	52.8	14.0	67.6	55.2	13.1	65.6	57.8	12.2	63.5	60.7	11.3
51.0	73.6	51.2	15.2	71.7	53.5	14.3	69.7	55.9	13.4	67.7	58.5	12.4	65.5	61.3	11.6
53.0	75.9	52.0	15.5	74.0	54.2	14.6	71.9	56.6	13.6	69.8	59.2	12.7	67.6	62.1	11.8
55.0	78.3	52.8	15.8	76.3	55.0	14.8	74.2	57.4	13.9	72.0	60.0	12.9	69.7	62.8	12.0

indicates package unloaded due to high pressure conditions

? indicates no rating available at this condition

MODEL: YCUL0055EE**AIR TEMPERATURE ON - CONDENSER (°F)**

SST (°F)	100.0			105.0			110.0			115.0		
	TONS	KW	EER	TONS	KW	EER	TONS	KW	EER	TONS	KW	EER
35.0	41.8	49.7	8.9	40.3	52.5	8.2	38.8	55.5	7.5	37.1	58.7	6.8
37.0	43.4	50.1	9.2	41.8	52.9	8.4	40.2	55.9	7.7	38.5	59.0	7.0
39.0	44.9	50.4	9.4	43.3	53.2	8.7	41.7	56.2	7.9	39.9	59.4	7.2
41.0	46.5	50.8	9.7	44.9	53.6	8.9	43.2	56.6	8.2	41.4	59.8	7.5
43.0	48.2	51.2	10.0	46.5	54.0	9.2	44.7	57.0	8.4	42.8	60.1	7.7
45.0	49.9	51.6	10.3	48.1	54.4	9.4	46.2	57.4	8.7	44.3	60.5	7.9
47.0	51.6	52.0	10.5	49.7	54.8	9.7	47.8	57.8	8.9	45.9	60.9	8.1
49.0	53.3	52.4	10.8	51.4	55.2	10.0	49.5	58.2	9.1	47.4	61.4	8.4
51.0	55.1	52.9	11.1	53.2	55.6	10.2	51.1	58.6	9.4	49.1	61.8	8.6
53.0	57.0	53.3	11.4	54.9	56.1	10.5	52.8	59.1	9.6	50.7	62.3	8.8
55.0	58.8	53.8	11.7	56.7	56.6	10.8	54.6	59.6	9.9	52.4	62.7	9.0

MODEL: YCUL0065EE**AIR TEMPERATURE ON - CONDENSER (°F)**

SST (°F)	100.0			105.0			110.0			115.0		
	TONS	KW	EER	TONS	KW	EER	TONS	KW	EER	TONS	KW	EER
35.0	48.3	59.8	8.7	46.5	63.1	8.0	44.6	66.6	7.3	42.6	70.3	6.6
37.0	50.1	60.3	9.0	48.2	63.6	8.2	46.2	67.1	7.5	44.2	70.8	6.8
39.0	51.9	60.8	9.2	49.9	64.1	8.5	47.9	67.6	7.7	45.9	71.3	7.1
41.0	53.7	61.3	9.5	51.7	64.6	8.7	49.6	68.1	8.0	47.5	71.8	7.3
43.0	55.6	61.8	9.7	53.5	65.1	8.9	51.4	68.6	8.2	49.2	72.3	7.5
45.0	57.4	62.4	10.0	55.3	65.7	9.2	53.1	69.2	8.4	50.9	72.9	7.7
47.0	59.4	63.0	10.2	57.2	66.3	9.4	54.9	69.8	8.6	52.6	73.5	7.9
49.0	61.3	63.7	10.4	59.1	66.9	9.6	56.8	70.4	8.8	54.4	74.1	8.1
51.0	63.3	64.4	10.7	61.0	67.6	9.9	58.6	71.1	9.0	56.2	74.8	8.3
53.0	65.3	65.1	10.9	63.0	68.3	10.1	60.5	71.8	9.3	58.0	75.4	8.5
55.0	67.4	65.8	11.1	64.9	69.0	10.3	62.5	72.5	9.5	59.9	76.2	8.7

indicates package unloaded due to high pressure conditions

? indicates no rating available at this condition

Ratings - R-410A (60Hz - English Units) - Cont.

MODEL: YCUL0072EE

AIR TEMPERATURE ON - CONDENSER (°F)

SST (°F)	75.0			80.0			85.0			90.0			95.0		
	TONS	KW	EER	TONS	KW	EER	TONS	KW	EER	TONS	KW	EER	TONS	KW	EER
35.0	69.9	58.2	12.9	67.9	61.1	12.0	65.8	64.2	11.1	63.7	67.7	10.3	61.6	71.4	9.5
37.0	72.5	58.9	13.2	70.4	61.8	12.3	68.2	64.9	11.4	66.1	68.3	10.6	63.9	72.1	9.7
39.0	75.1	59.6	13.6	72.9	62.5	12.6	70.7	65.6	11.7	68.5	69.0	10.8	66.2	72.8	10.0
41.0	77.7	60.4	13.9	75.5	63.2	12.9	73.2	66.4	12.0	70.9	69.8	11.1	68.6	73.5	10.3
43.0	80.4	61.1	14.2	78.1	64.0	13.3	75.8	67.1	12.3	73.4	70.6	11.4	71.0	74.3	10.5
45.0	83.2	61.9	14.5	80.8	64.8	13.6	78.4	67.9	12.6	75.9	71.4	11.7	73.5	75.1	10.8
47.0	86.0	62.7	14.9	83.5	65.6	13.9	81.0	68.8	12.9	78.5	72.2	11.9	76.0	75.9	11.0
49.0	88.9	63.5	15.2	86.3	66.4	14.2	83.8	69.6	13.2	81.2	73.1	12.2	78.6	76.8	11.3
51.0	91.8	64.4	15.5	89.2	67.3	14.5	86.5	70.5	13.4	83.9	73.9	12.5	81.2	77.7	11.5
53.0	94.8	65.3	15.8	92.1	68.2	14.7	89.4	71.4	13.7	86.6	74.9	12.7	83.9	78.6	11.8
55.0	97.8	66.2	16.1	95.1	69.2	15.0	92.2	72.4	14.0	89.4	75.8	13.0	86.6	79.6	12.0

indicates package unloaded due to high pressure conditions

? indicates no rating available at this condition

MODEL: YCUL0072EE

AIR TEMPERATURE ON - CONDENSER (°F)												
SST (°F)	100.0			105.0			110.0			115.0		
	TONS	KW	EER	TONS	KW	EER	TONS	KW	EER	TONS	KW	EER
35.0	59.5	75.4	8.7	57.3	79.8	7.9	55.1	84.5	7.3	52.9	89.5	6.6
37.0	61.7	76.1	8.9	59.4	80.4	8.2	57.2	85.1	7.5	54.9	90.2	6.8
39.0	63.9	76.8	9.2	61.6	81.1	8.4	59.3	85.8	7.7	56.9	90.9	7.0
41.0	66.2	77.5	9.4	63.8	81.9	8.6	61.4	86.5	7.9	59.0	91.6	7.2
43.0	68.6	78.3	9.7	66.1	82.6	8.9	63.6	87.3	8.1	45.4	62.0	7.9#
45.0	71.0	79.1	9.9	68.4	83.4	9.1	65.9	88.1	8.3	47.1	62.4	8.2#
47.0	73.4	79.9	10.2	70.8	84.2	9.3	68.2	88.9	8.6	48.8	62.9	8.4#
49.0	75.9	80.8	10.4	73.2	85.1	9.6	70.5	89.8	8.8	50.5	63.4	8.7#
51.0	78.5	81.7	10.7	75.7	86.0	9.8	72.9	90.7	9.0	52.3	63.8	8.9#
53.0	81.1	82.6	10.9	78.2	86.9	10.0	75.4	91.6	9.2	38.8	41.8	9.6@
55.0	83.7	83.6	11.1	80.8	87.9	10.2	77.9	92.6	9.4	40.2	42.1	9.9@

indicates package unloaded due to high pressure conditions

? indicates no rating available at this condition

Ratings - R-410A (50Hz - English Units)

MODEL: YCUL0045EE

AIR TEMPERATURE ON - CONDENSER (F)

SST (F)	75.0			80.0			85.0			90.0			95.0		
	TONS	KW	EER	TONS	KW	EER	TONS	KW	EER	TONS	KW	EER	TONS	KW	EER
35.0	32.6	24.3	14.2	31.7	25.9	13.1	30.8	27.6	12.0	29.8	29.4	10.9	28.7	31.4	9.9
37.0	33.8	24.5	14.6	32.9	26.1	13.5	31.9	27.7	12.4	30.9	29.5	11.3	29.8	31.5	10.3
39.0	35.0	24.7	15.1	34.1	26.2	13.9	33.1	27.9	12.8	32.0	29.7	11.7	30.9	31.6	10.6
41.0	36.2	24.8	15.5	35.3	26.4	14.3	34.3	28.0	13.1	33.2	29.8	12.0	32.1	31.8	11.0
43.0	37.5	25.0	15.9	36.5	26.6	14.7	35.5	28.2	13.5	34.4	30.0	12.4	33.3	31.9	11.3
45.0	38.8	25.2	16.3	37.8	26.8	15.1	36.7	28.4	13.9	35.6	30.2	12.8	34.4	32.1	11.7
47.0	40.1	25.5	16.8	39.1	27.0	15.5	38.0	28.6	14.3	36.9	30.4	13.2	35.7	32.3	12.0
49.0	41.4	25.7	17.2	40.4	27.2	15.9	39.3	28.8	14.7	38.1	30.6	13.5	36.9	32.5	12.4
51.0	42.8	25.9	17.6	41.7	27.4	16.3	40.6	29.0	15.1	39.4	30.8	13.9	38.2	32.7	12.8
53.0	44.2	26.2	18.0	43.1	27.7	16.7	41.9	29.3	15.5	40.7	31.0	14.3	39.5	32.9	13.1
55.0	45.6	26.5	18.4	44.5	28.0	17.1	43.3	29.5	15.9	42.1	31.3	14.6	40.8	33.1	13.5

MODEL: YCUL0051EE

AIR TEMPERATURE ON - CONDENSER (F)

SST (F)	75.0			80.0			85.0			90.0			95.0		
	TONS	KW	EER	TONS	KW	EER	TONS	KW	EER	TONS	KW	EER	TONS	KW	EER
35.0	34.8	26.8	13.9	33.8	28.4	12.8	32.7	30.2	11.7	31.7	32.2	10.7	30.6	34.3	9.8
37.0	36.0	26.9	14.3	35.0	28.6	13.2	33.9	30.4	12.1	32.9	32.3	11.1	31.7	34.4	10.1
39.0	37.3	27.1	14.7	36.3	28.8	13.6	35.2	30.6	12.5	34.1	32.5	11.4	32.9	34.6	10.4
41.0	38.7	27.3	15.2	37.6	29.0	14.0	36.5	30.8	12.9	35.3	32.7	11.8	34.1	34.8	10.8
43.0	40.0	27.5	15.6	38.9	29.2	14.4	37.8	31.0	13.2	36.6	32.9	12.1	35.3	35.0	11.1
45.0	41.4	27.8	16.0	40.3	29.4	14.8	39.1	31.2	13.6	37.9	33.1	12.5	36.6	35.2	11.4
47.0	42.8	28.0	16.4	41.7	29.7	15.2	40.4	31.4	14.0	39.2	33.3	12.9	37.9	35.4	11.8
49.0	44.3	28.3	16.9	43.1	29.9	15.6	41.8	31.7	14.4	40.5	33.6	13.2	39.2	35.6	12.1
51.0	45.8	28.5	17.3	44.5	30.2	16.0	43.2	31.9	14.8	41.9	33.8	13.6	40.6	35.9	12.4
53.0	47.3	28.8	17.7	46.0	30.4	16.4	44.7	32.2	15.1	43.3	34.1	13.9	41.9	36.1	12.8
55.0	48.8	29.1	18.1	47.5	30.7	16.8	46.2	32.5	15.5	44.8	34.4	14.3	43.3	36.4	13.1

indicates package unloaded due to high pressure conditions

? indicates no rating available at this condition

MODEL: YCUL0045EE**AIR TEMPERATURE ON - CONDENSER (F)**

SST (F)	100.0			105.0			110.0			115.0		
	TONS	KW	EER	TONS	KW	EER	TONS	KW	EER	TONS	KW	EER
35.0	27.6	33.5	9.0	26.5	35.8	8.1	25.3	38.3	7.3	24.0	41.0	6.5
37.0	28.7	33.6	9.3	27.5	35.9	8.4	26.3	38.4	7.6	25.0	41.0	6.8
39.0	29.8	33.7	9.7	28.6	36.0	8.7	27.3	38.5	7.9	26.1	41.1	7.0
41.0	30.9	33.9	10.0	29.7	36.1	9.0	28.4	38.6	8.2	27.1	41.2	7.3
43.0	32.1	34.0	10.3	30.8	36.3	9.4	29.5	38.7	8.4	28.1	41.3	7.6
45.0	33.2	34.2	10.7	31.9	36.4	9.7	30.6	38.8	8.7	29.2	41.4	7.8
47.0	34.4	34.3	11.0	33.1	36.6	10.0	31.7	39.0	9.0	30.3	41.6	8.1
49.0	35.6	34.5	11.3	34.3	36.7	10.3	32.9	39.1	9.3	31.4	41.7	8.4
51.0	36.9	34.7	11.7	35.5	36.9	10.6	34.1	39.3	9.6	32.6	41.9	8.7
53.0	38.1	34.9	12.0	36.7	37.1	10.9	35.3	39.5	9.9	33.8	42.1	8.9
55.0	39.4	35.2	12.3	38.0	37.3	11.2	36.5	39.7	10.2	35.0	42.3	9.2

MODEL: YCUL0051EE**AIR TEMPERATURE ON - CONDENSER (F)**

SST (F)	100.0			105.0			110.0			115.0		
	TONS	KW	EER	TONS	KW	EER	TONS	KW	EER	TONS	KW	EER
35.0	29.4	36.5	8.9	28.2	38.9	8.0	27.0	41.5	7.2	25.7	44.3	6.5
37.0	30.5	36.7	9.2	29.3	39.1	8.3	28.0	41.6	7.5	26.7	44.4	6.7
39.0	31.7	36.8	9.5	30.4	39.2	8.6	29.1	41.8	7.8	27.8	44.6	7.0
41.0	32.9	37.0	9.8	31.6	39.4	8.9	30.3	42.0	8.0	28.9	44.7	7.2
43.0	34.1	37.2	10.1	32.8	39.6	9.2	31.4	42.2	8.3	30.0	44.9	7.5
45.0	35.3	37.4	10.4	34.0	39.8	9.5	32.6	42.4	8.6	31.1	45.1	7.7
47.0	36.6	37.6	10.7	35.2	40.0	9.8	33.8	42.6	8.8	32.3	45.3	8.0
49.0	37.8	37.8	11.1	36.4	40.2	10.1	35.0	42.8	9.1	33.4	45.5	8.2
51.0	39.2	38.1	11.4	37.7	40.5	10.4	36.2	43.0	9.4	34.6	45.8	8.5
53.0	40.5	38.3	11.7	39.0	40.7	10.6	37.5	43.3	9.7	35.9	46.0	8.7
55.0	41.9	38.6	12.0	40.3	41.0	10.9	38.8	43.5	9.9	37.1	46.3	9.0

indicates package unloaded due to high pressure conditions

? indicates no rating available at this condition

Ratings - R-410A (50Hz - English Units)

MODEL: YCUL0055EE

AIR TEMPERATURE ON - CONDENSER (F)

SST (F)	75.0			80.0			85.0			90.0			95.0		
	TONS	KW	EER	TONS	KW	EER	TONS	KW	EER	TONS	KW	EER	TONS	KW	EER
35.0	40.0	29.7	14.3	39.0	31.4	13.2	37.9	33.3	12.2	36.8	35.3	11.3	35.7	37.5	10.4
37.0	41.4	30.0	14.7	40.4	31.7	13.6	39.3	33.5	12.6	38.2	35.5	11.6	37.0	37.6	10.7
39.0	42.9	30.2	15.1	41.8	31.9	14.0	40.7	33.7	13.0	39.6	35.7	12.0	38.4	37.9	11.0
41.0	44.4	30.5	15.5	43.3	32.1	14.4	42.2	33.9	13.4	41.0	35.9	12.4	39.7	38.1	11.4
43.0	45.9	30.8	15.9	44.8	32.4	14.8	43.6	34.2	13.8	42.4	36.2	12.7	41.2	38.3	11.7
45.0	47.5	31.1	16.3	46.4	32.7	15.2	45.2	34.5	14.1	43.9	36.4	13.1	42.6	38.5	12.0
47.0	49.1	31.4	16.7	47.9	33.0	15.6	46.7	34.7	14.5	45.4	36.7	13.4	44.1	38.8	12.4
49.0	50.8	31.7	17.1	49.5	33.3	16.0	48.3	35.0	14.9	46.9	37.0	13.8	45.6	39.1	12.7
51.0	52.4	32.1	17.5	51.2	33.6	16.4	49.9	35.4	15.2	48.5	37.3	14.1	47.1	39.4	13.1
53.0	54.1	32.5	17.9	52.9	34.0	16.7	51.5	35.7	15.6	50.1	37.6	14.5	48.7	39.7	13.4
55.0	55.9	32.9	18.2	54.6	34.4	17.1	53.2	36.1	16.0	51.7	37.9	14.8	50.2	40.0	13.7

MODEL: YCUL0065EE

AIR TEMPERATURE ON - CONDENSER (F)

SST (F)	75.0			80.0			85.0			90.0			95.0		
	TONS	KW	EER	TONS	KW	EER	TONS	KW	EER	TONS	KW	EER	TONS	KW	EER
35.0	46.1	36.4	13.7	45.0	38.5	12.7	43.7	40.8	11.7	42.4	43.2	10.8	41.1	45.9	9.9
37.0	47.8	36.7	14.1	46.6	38.8	13.1	45.3	41.1	12.1	44.0	43.5	11.1	42.6	46.2	10.2
39.0	49.5	37.0	14.5	48.2	39.1	13.5	46.9	41.4	12.4	45.5	43.8	11.5	44.1	46.5	10.5
41.0	51.2	37.4	14.9	49.9	39.4	13.8	48.5	41.7	12.8	47.1	44.1	11.8	45.7	46.8	10.8
43.0	52.9	37.7	15.3	51.6	39.8	14.2	50.2	42.0	13.1	48.8	44.5	12.1	47.2	47.1	11.1
45.0	54.7	38.1	15.6	53.3	40.1	14.5	51.9	42.4	13.5	50.4	44.8	12.4	48.9	47.4	11.4
47.0	56.5	38.5	16.0	55.1	40.5	14.9	53.7	42.7	13.8	52.1	45.2	12.8	50.5	47.8	11.7
49.0	58.4	39.0	16.4	57.0	40.9	15.3	55.4	43.1	14.2	53.9	45.5	13.1	52.2	48.2	12.0
51.0	60.3	39.4	16.7	58.8	41.4	15.6	57.3	43.5	14.5	55.6	45.9	13.4	54.0	48.6	12.3
53.0	62.3	39.9	17.1	60.7	41.8	15.9	59.1	44.0	14.8	57.5	46.4	13.7	55.7	49.0	12.7
55.0	64.2	40.4	17.4	62.7	42.3	16.3	61.0	44.4	15.1	59.3	46.8	14.0	57.5	49.4	13.0

indicates package unloaded due to high pressure conditions

? indicates no rating available at this condition

MODEL: YCUL0055EE**AIR TEMPERATURE ON - CONDENSER (F)**

SST (F)	100.0			105.0			110.0			115.0		
	TONS	KW	EER	TONS	KW	EER	TONS	KW	EER	TONS	KW	EER
35.0	34.5	39.8	9.5	33.3	42.2	8.7	32.0	44.8	7.9	30.7	47.6	7.2
37.0	35.8	40.0	9.8	34.5	42.4	8.9	33.2	45.1	8.2	31.9	47.8	7.4
39.0	37.1	40.2	10.1	35.8	42.7	9.2	34.5	45.3	8.4	33.1	48.1	7.6
41.0	38.5	40.4	10.4	37.1	42.9	9.5	35.7	45.5	8.7	34.3	48.3	7.9
43.0	39.8	40.6	10.7	38.5	43.1	9.8	37.0	45.7	9.0	35.6	48.5	8.1
45.0	41.2	40.9	11.1	39.8	43.3	10.1	38.4	46.0	9.2	36.9	48.8	8.4
47.0	42.7	41.1	11.4	41.2	43.6	10.4	39.7	46.2	9.5	38.2	49.1	8.7
49.0	44.1	41.4	11.7	42.6	43.9	10.7	41.1	46.5	9.8	39.5	49.3	8.9
51.0	45.6	41.7	12.0	44.1	44.1	11.0	42.5	46.8	10.1	40.9	49.6	9.2
53.0	47.1	42.0	12.3	45.6	44.4	11.3	43.9	47.1	10.4	42.3	49.9	9.4
55.0	48.7	42.3	12.7	47.1	44.7	11.6	45.4	47.4	10.6	43.7	50.2	9.7

MODEL: YCUL0065EE**AIR TEMPERATURE ON - CONDENSER (F)**

SST (F)	100.0			105.0			110.0			115.0		
	TONS	KW	EER	TONS	KW	EER	TONS	KW	EER	TONS	KW	EER
35.0	39.7	48.7	9.1	38.2	51.7	8.3	36.8	54.8	7.5	35.2	58.2	6.8
37.0	41.1	49.0	9.3	39.6	52.0	8.5	38.1	55.2	7.7	36.5	58.5	7.0
39.0	42.6	49.3	9.6	41.1	52.3	8.8	39.5	55.5	8.0	37.9	58.9	7.2
41.0	44.1	49.6	9.9	42.6	52.6	9.0	40.9	55.8	8.2	39.3	59.2	7.5
43.0	45.7	49.9	10.2	44.1	53.0	9.3	42.4	56.2	8.5	40.7	59.6	7.7
45.0	47.3	50.3	10.5	45.6	53.3	9.6	43.9	56.5	8.7	42.1	60.0	7.9
47.0	48.9	50.6	10.8	47.2	53.7	9.8	45.4	56.9	9.0	43.6	60.3	8.1
49.0	50.5	51.0	11.0	48.8	54.0	10.1	47.0	57.3	9.2	45.1	60.7	8.4
51.0	52.2	51.4	11.3	50.4	54.4	10.4	48.6	57.7	9.5	46.6	61.1	8.6
53.0	53.9	51.8	11.6	52.1	54.8	10.6	50.2	58.1	9.7	48.2	61.5	8.8
55.0	55.7	52.2	11.9	53.8	55.2	10.9	51.8	58.5	10.0	49.8	61.9	9.1

indicates package unloaded due to high pressure conditions

? indicates no rating available at this condition

Ratings - R-410A (50Hz - English Units)

MODEL: YCUL0072EE

AIR TEMPERATURE ON - CONDENSER (F)

SST (F)	75.0			80.0			85.0			90.0			95.0		
	TONS	KW	EER	TONS	KW	EER	TONS	KW	EER	TONS	KW	EER	TONS	KW	EER
35.0	58.5	47.3	13.7	56.8	49.9	12.7	55.1	52.6	11.7	53.4	55.6	10.8	51.6	58.9	9.9
37.0	60.6	47.8	14.1	58.9	50.3	13.0	57.1	53.1	12.0	55.3	56.1	11.1	53.5	59.4	10.1
39.0	62.7	48.3	14.4	61.0	50.8	13.4	59.1	53.6	12.3	57.3	56.6	11.4	55.4	59.9	10.4
41.0	64.9	48.8	14.8	63.1	51.3	13.7	61.2	54.1	12.7	59.3	57.1	11.7	57.4	60.4	10.7
43.0	67.1	49.3	15.1	65.3	51.9	14.0	63.3	54.7	13.0	61.4	57.7	12.0	59.4	61.0	11.0
45.0	69.4	49.9	15.5	67.5	52.4	14.4	65.5	55.2	13.3	63.5	58.2	12.3	61.5	61.5	11.3
47.0	71.7	50.5	15.8	69.8	53.0	14.7	67.7	55.8	13.6	65.7	58.8	12.6	63.6	62.1	11.6
49.0	74.1	51.1	16.2	72.1	53.6	15.0	70.0	56.4	13.9	67.9	59.4	12.9	65.7	62.7	11.8
51.0	76.5	51.7	16.5	74.4	54.3	15.4	72.3	57.0	14.2	70.1	60.1	13.2	67.9	63.4	12.1
53.0	79.0	52.4	16.9	76.8	54.9	15.7	74.6	57.7	14.5	72.4	60.7	13.4	70.1	64.0	12.4
55.0	81.5	53.1	17.2	79.3	55.6	16.0	77.0	58.4	14.8	74.7	61.4	13.7	72.4	64.7	12.7

indicates package unloaded due to high pressure conditions

? indicates no rating available at this condition

MODEL: YCUL0072EE**AIR TEMPERATURE ON - CONDENSER (F)**

SST (F)	100.0			105.0			110.0			115.0		
	TONS	KW	EER	TONS	KW	EER	TONS	KW	EER	TONS	KW	EER
35.0	49.8	62.4	9.0	48.0	66.2	8.2	46.1	70.2	7.5	44.2	74.6	6.8
37.0	51.6	62.9	9.3	49.7	66.7	8.5	47.8	70.7	7.7	45.8	75.1	7.0
39.0	53.5	63.4	9.5	51.6	67.2	8.7	49.6	71.3	7.9	47.5	75.7	7.2
41.0	55.4	63.9	9.8	53.4	67.7	8.9	51.4	71.8	8.1	49.3	76.2	7.4
43.0	57.4	64.5	10.1	55.3	68.3	9.2	53.2	72.4	8.4	51.1	76.8	7.6
45.0	59.4	65.1	10.3	57.2	68.9	9.4	55.1	73.0	8.6	52.9	77.4	7.8
47.0	61.4	65.7	10.6	59.2	69.5	9.7	57.0	73.6	8.8	40.7	51.9	8.8#
49.0	63.5	66.3	10.9	61.2	70.1	9.9	59.0	74.2	9.1	42.1	52.2	9.0#
51.0	65.6	66.9	11.1	63.3	70.7	10.2	61.0	74.9	9.3	43.6	52.6	9.3#
53.0	67.8	67.6	11.4	65.4	71.4	10.4	63.0	75.5	9.5	45.1	52.9	9.5#
55.0	70.0	68.3	11.6	67.6	72.1	10.7	65.1	76.2	9.7	46.7	53.3	9.8#

indicates package unloaded due to high pressure conditions

? indicates no rating available at this condition

Physical Data - English & SI

60Hz

Model No. YCUL		0045	0051	0055	0065	0072	
Length		144.8	144.8	148.8	148.8	153.6	
Width		90.6	90.6	90.6	90.6	90.6	
Height		47.8	47.8	62.6	62.6	62.6	
Nominal Tons		41.6	44.1	51.6	59.5	73.5	
Number of Refrigerant Circuits		2	2	2	2	2	
Refrig. Chg, Opt, R-410A (lbs) ckt1/ckt2		35/35	40/35	45/45	50/50	65/65	
Oil Charge, gallons ckt1/ckt2		1.8/1.8	1.8/1.8	1.7/1.7	1.7/1.7	2.3/2.2	
Shipping Weight	Alum. Fin Coils, lbs	2942	2968	3196	3208	4097	
	Copper Fin Coils, lbs	3300	3326	3673	3685	4703	
Operating Weight	Alum. Fin Coils, lbs	2967	3001	3233	3245	4142	
	Copper Fin Coils, lbs	3325	3359	3710	3722	4748	
Nominal Comp. Capacity	Comp. 1	10	12	13	15	20	
	Comp. 2	10	12	13	15	20	
	Comp. 3	–	–	–	–	–	
	Comp. 4	10	10	13	15	15	
	Comp. 5	10	10	13	15	15	
	Comp. 6	–	–	–	–	–	
Condenser	Total Face Area ft ²		87	87	116	116	128
	Number of Rows Deep	Ckt. 1	2	2	3	3	3
		Ckt. 2	2	2	3	3	3
	Fins per Inch		17	17	17	17	13
Condenser Fans, Low Sound	Number of Fans	Ckt. 1	2	2	2	2	2
		Ckt. 2	2	2	2	2	2
	Fan Power hp/fan		1.2	1.2	1.2	1.2	1.2
	Fan RPM		950	950	950	950	950
	Total Chiller CFM		39500	39500	43333	43333	43333
Condenser Fans, Ultra Quiet	Number of Fans	Ckt. 1	2	2	2	2	2
		Ckt. 2	2	2	2	2	2
	Fan Power hp/fan		1.2	1.2	1.2	1.2	1.2
	Fan RPM		698	698	698	698	698
	Total Chiller CFM		39500	39500	43333	43333	43333

50Hz

Model No. YCUL		0045	0051	0055	0065	0072	
Length		3677.9	3677.9	3779.5	3779.5	3901.4	
Width		2301.2	2301.2	2301.2	2301.2	2301.2	
Height		1214.1	1214.1	1590	1590	1590	
Nominal Tons		146.3	155.1	181.5	209.3	258.5	
Number of Refrigerant Circuits		2	2	2	2	2	
Refrig. Chg, Opt, R-410A (kg) ckt1/ckt2		15.9/15.9	18.1/15.9	20.4/20.4	22.7/22.7	29.5/29.5	
Oil Charge, gallons ckt1/ckt2		6.8/6.8	6.8/6.8	6.4/6.4	6.4/6.4	8.7/8.3	
Shipping Weight	Alum. Fin Coils, lbs	1334.5	1346.3	1449.7	1455.1	1858.4	
	Copper Fin Coils, lbs	1496.9	1508.6	1666	1671.5	2133.2	
Operating Weight	Alum. Fin Coils, lbs	1345.8	1361.2	1466.5	1471.9	1878.8	
	Copper Fin Coils, lbs	1508.2	1523.6	1682.8	1688.3	2153.7	
Nominal Comp. Capacity	Comp. 1	35.1	42.2	45.7	52.7	70.3	
	Comp. 2	35.1	42.2	45.7	52.7	70.3	
	Comp. 3	—	—	—	—	—	
	Comp. 4	35.1	35.1	45.7	52.7	52.7	
	Comp. 5	35.1	35.1	45.7	52.7	52.7	
	Comp. 6	—	—	—	—	—	
Condenser	Total Face Area ft ²		8.1	8.1	10.8	10.8	11.9
	Number of Rows Deep	Ckt. 1	2	2	3	3	3
		Ckt. 2	2	2	3	3	3
	Fins per Inch		17	17	17	17	13
Condenser Fans, Low Sound	Number of Fans	Ckt. 1	2	2	2	2	2
		Ckt. 2	2	2	2	2	2
	Fan Power kW/fan		0.9	0.9	0.9	0.9	0.9
	Fan RPM		950	950	950	950	950
	Total Chiller CFM		18641.7	18641.7	20450.7	20450.7	20450.7
	Condenser Fans, Ultra Quiet	Number of Fans	Ckt. 1	2	2	2	2
Ckt. 2			2	2	2	2	2
Fan Power hp/fan		0.9	0.9	0.9	0.9	0.9	
Fan RPM		698	698	698	698	698	
Total Chiller CFM		18641.7	18641.7	20450.7	20450.7	20450.7	

Dimensions

5/8" DIA MOUNTING HOLES (TYP)

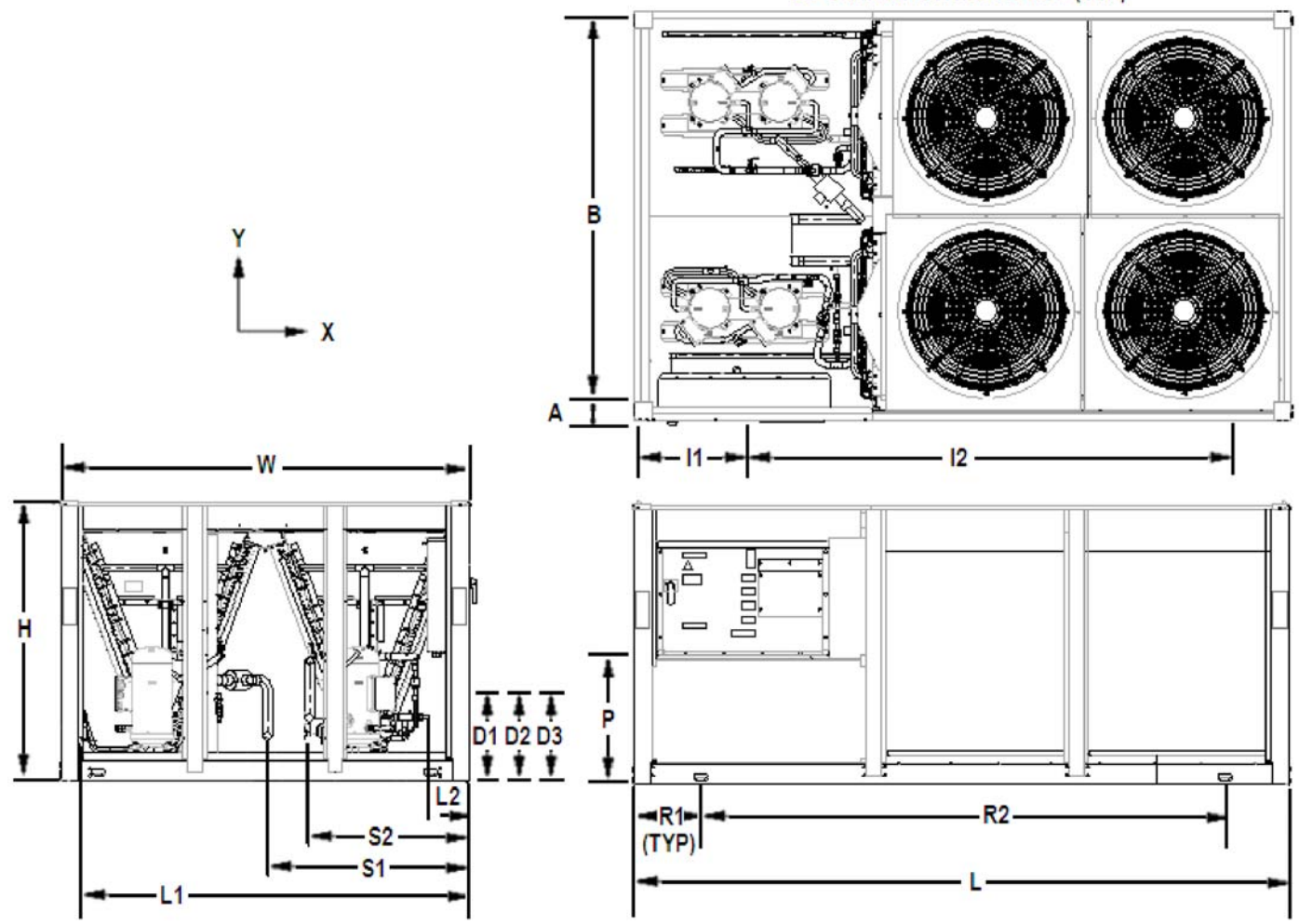

UNIT DIMENSIONS

60 HZ Model		YCUL0045EE	YCUL0051EE	YCUL0055EE	YCUL0065EE	YCUL0072EE
Length	L	144.8	144.8	148.8	148.8	153.6
Width	W	90.6	90.6	90.6	90.6	90.6
Height	H	47.8	47.8	62.6	62.6	62.6
	F					
	P	13.6	13.6	28.5	28.5	28.5
Connection Sizes	Suction In 1	2.1	2.1	2.1	2.1	2.3
	Suction In 2					2.1
	Liquid Out 1 / 2	1.1	1.1	1.1	1.1	1.1
System 1 Dimensions	Suction In	48.7	48.7	52.7	44.4	53.7
	Liquid Out	72.9	72.9	85.1	85.1	77.6
System 2 Dimensions	Suction In	41.6	41.6	35.1	35.1	33.3
	Liquid Out	17.3	17.3	14.1	14.1	15
	D1	19.6	19.7	24	9.7	6.8
	D2	6.4	6.4	9.1	9.1	5.3
	D3			13.8	13.8	9.2
	D4					
Isolator Location Dimensions	I1	9.8	9.8	9.8	9.8	9.8
	I2	135	135	135	135	143.8
	I3					
	I4					
	I5					
	I6					
	I7					
	I8					
	A	1.1	1.1	1.1	1.1	1.1
	B	89.5	89.5	89.5	89.5	89.5
Rigging Hole Locations	R1	15.1	15.1	15.1	15.1	15.1
	R2	130.9	130.9	130.9	130.8	137.6
	R3					
	R4					
Unit COG	X	59.6	59.2	61.9	61.5	59.7
	Y	43.6	43.5	42.2	42.2	44.9

Isolator Selections

ONE INCH DEFLECTION SPRING ISOLATOR CROSS-REFERENCE

CPX-X-

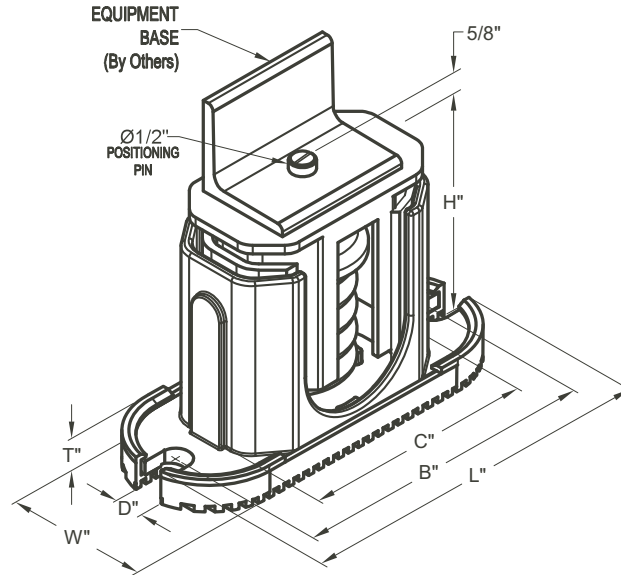

Mount Type	Dimension Data (Inches)						
	W	D	L	B	C	T	H
CP1	3	5/8	7-3/4	6-1/2	4-3/4	1/2	5-5/8
CP2	3	5/8	10-1/2	9-1/4	7-3/4	9/16	6

MODEL NUMBER	RATED CAPACITY (LBS.)	DEFLECTION RATED (IN)	COLOR CODE
CP1-1D-85	85	1.360	LT. PURPLE
CP1-1D-120	120	1.200	DK. YELLOW
CP1-1D-175	175	1.170	DK. BLUE
CP1-1D-250	250	1.400	YELLOW
CP1-1D-340	340	1.130	RED
CP1-1D-510	510	1.020	BLACK
CP1-1D-675	675	1.320	DK. PURPLE
CP1-1D-900	900	1.020	DK. GREEN
CP1-1D-1200	1200	0.900	GRAY
CP1-1D-1360	1360	0.770	WHITE
CP1-1D-1785N	1785	0.880	GRAY/RED

MODEL NUMBER	RATED CAPACITY (LBS.)	DEFLECTION RATED (IN)	COLOR CODE
CP2-1D-1020	1020	1.020	BLACK
CP2-1D-1350	1350	1.320	DK. PURPLE
CP2-1D-1800	1800	1.020	DK. GREEN
CP2-1D-2400	2400	0.900	GRAY
CP2-1D-2720	2720	0.770	WHITE
CP2-1D-3570N	3570	0.880	GRAY / RED

NEOPRENE ISOLATOR CROSS-REFERENCE

RD-Style Isolators

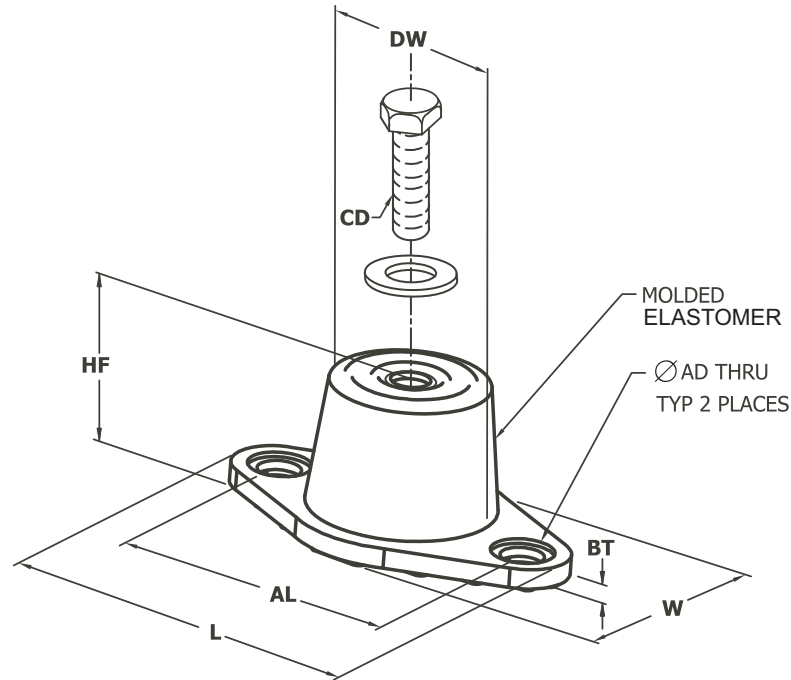

Mount Type	Dimension Data (inches)							
	L	W	HF	AL	AD	BT	CD	DW
RD1-WR	3.13	1.75	1.25	2.38	0.34	0.19	5/16-18 UNC X 3/4	1.25
RD2-WR	3.88	2.38	1.75	3.00	0.34	0.22	3/8-16 UNC X 1	1.75
RD3-WR	5.50	3.38	2.88	4.13	0.56	0.25	1/2-13 UNC X 1	2.50
RD4-WR	6.25	4.63	2.75	5.00	0.56	0.38	1/2-13 UNC X 1	3.00

MODEL NUMBER	RATED CAPACITY [LBS]	RATED DEFLECTION [IN]	DURO (± 5)
RD2-Light Blue-WR	35	0.4	30
RD2-Brown-WR	45	0.4	40
RD2-Brick Red-WR	70	0.4	50
RD 2-Lime-WR	120	0.4	60

MODEL NUMBER	RATED CAPACITY [LBS]	RATED DEFLECTION [IN]	DURO (± 5)
RD3-Brown-WR	250	0.5	40
RD3-Brick Red-WR	525	0.5	50
RD3-Lime-WR	750	0.5	60
RD3-Charcoal-WR	1100	0.5	70

MODEL NUMBER	RATED CAPACITY [LBS]	RATED DEFLECTION [IN]	DURO (± 5)
RD2-Light Blue-WR	135	0.5	30
RD2-Brown-WR	170	0.5	40
RD2-Brick Red-WR	240	0.5	50
RD 2-Lime-WR	380	0.5	60
RD2 Charcoal-WR	550	0.5	70

MODEL NUMBER	RATED CAPACITY [LBS]	RATED DEFLECTION [IN]	DURO (± 5)
RD4-Brown-WR	1500	0.5	40
RD4-Brick Red-WR	2250	0.5	50
RD4-Lime-WR	3000	0.5	60
RD4-Charcoal-WR	4000	0.5	70

Isolator Details - continued

TWO INCH DEFLECTION, SEISMIC SPRING ISOLATOR CROSS-REFERENCE

Y2RS

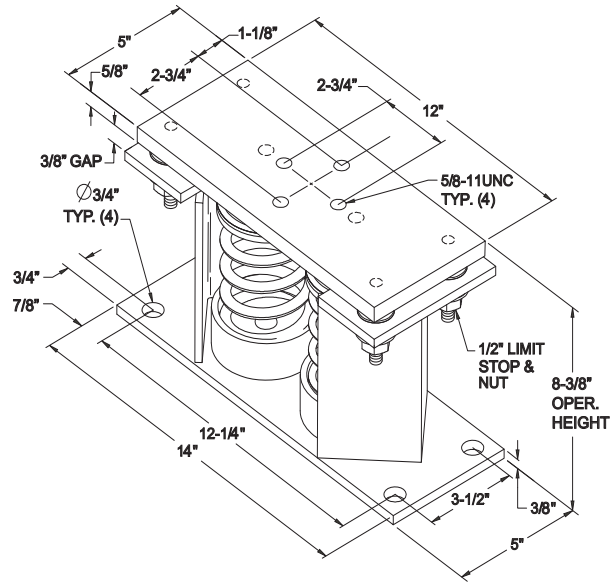

MODEL Y2RSI-2D SEISMICALLY RESTRAINED VIBRATION ISOLATOR FOR 2\" DEFLECTION

SEISMIC MOUNT SIZE	RATED LOAD (LBS)	RATED DEFLECTION (IN)	SPRING RATE (LBS/IN)	SOLID LOAD (LBS)	COLOR CODE	ALLOWABLE G RATING HORIZONTAL
Y2RSI-2D-150	150	2.4	62	234	WHITE	34.7
Y2RSI-2D-320	320	2.3	140	490	YELLOW	16.3
Y2RSI-2D-460	460	2.3	200	688	GREEN	11.3
Y2RSI-2D-710	710	2.2	330	1072	DK BROWN	7.3
Y2RSI-2D-870	870	1.9	460	1312	RED	6
Y2RSI-2D-1200N	1200	1.9	638	1818	RED/BLACK	4.3
Y2RSI-2D-1450	1450	1.8	900	2450	TAN	3.6
Y2RSI-2D-1690	1690	1.7	1140	2892	PINK	3.1
Y2RSI-2D-2000N	2000	1.7	1318	3342	PINK/BLACK	2.6
Y2RSI-2D-2640N	2640	1.5	1854	4283	PINK/GRAY	2
Y2RSI-2D-2870N	3080	1.5	2004	4629	PINK/GRAY/ORANGE	1.7
Y2RSI-2D-3280N	3740	1.8	2134	4930	PINK/GRAY/DK BROWN	1.4

Electrical Data - 50 & 60Hz

YCUL0045 - YCUL0072

CHILLER MODEL YCAL	VOLT	HZ	MINIMUM CIRCUIT AMPS MCA	MIN N/F DISC SW MDSW	MIN DUAL ELEM FUZE	MAX DUAL ELEM FUZE MAX CB	SYSTEM # 1						SYSTEM # 2							
							COMPR 1		COMPR 2		FAN		COMPR 1		COMPR 2		FAN			
							RLA	LRA	RLA	LRA	QTY	FLA	LRA	RLA	LRA	RLA	LRA	QTY	FLA	LRA
0045	200	60	224	250	250	250	45.4	250	45.4	250	2	7.6	30.9	45.4	250	45.4	250	2	7.6	30.9
	230	60	209	250	225	250	42.0	250	42.0	250	2	7.4	37.0	42.0	250	42.0	250	2	7.4	37.0
	380	60	121	150	150	150	24.2	155	24.2	155	2	4.5	22.3	24.2	155	24.2	155	2	4.5	22.3
	400	50	102	150	110	110	20.0	125	20.0	125	2	4.0	19.0	20.0	125	20.0	125	2	4.0	19.0
	460	60	99	150	110	110	20.0	125	20.0	125	2	3.4	17.2	20.0	125	20.0	125	2	3.4	17.2
	575	60	80	100	90	90	16.0	100	16.0	100	2	2.9	14.6	16.0	100	16.0	100	2	2.9	14.6
	400	50	102	150	110	110	20.0	125	20.0	125	2	4.0	19.0	20.0	125	20.0	125	2	4.0	19.0
0051	200	60	228	250	250	250	47.0	250	47.0	250	2	7.6	30.9	45.4	250	45.4	250	2	7.6	30.9
	230	60	212	250	225	250	43.5	250	43.5	250	2	7.4	37.0	42.0	250	42.0	250	2	7.4	37.0
	380	60	123	150	150	150	25.1	155	25.1	155	2	4.5	22.3	24.2	155	24.2	155	2	4.5	22.3
	400	50	103	150	110	110	20.7	125	20.7	125	2	4.0	19.0	20.0	125	20.0	125	2	4.0	19.0
	460	60	101	150	110	110	20.7	125	20.7	125	2	3.4	17.2	20.0	125	20.0	125	2	3.4	17.2
	575	60	81	100	90	90	16.6	100	16.6	100	2	2.9	14.6	16.0	100	16.0	100	2	2.9	14.6
	400	50	103	150	110	110	20.7	125	20.7	125	2	4.0	19.0	20.0	125	20.0	125	2	4.0	19.0
0055	200	60	248	400	300	300	51.3	300	51.3	300	2	7.6	44.0	51.3	300	51.3	300	2	7.6	44.0
	230	60	248	400	300	300	51.3	300	51.3	300	2	7.4	19.1	51.3	300	51.3	300	2	7.4	19.1
	380	60	132	150	150	150	26.9	139	26.9	139	2	4.5	23.1	26.9	139	26.9	139	2	4.5	23.1
	460	60	114	150	125	125	23.1	150	23.1	150	2	4.0	19.0	23.1	150	23.1	150	2	4.0	19.0
	575	60	96	150	110	110	19.9	109	19.9	109	2	2.9	15.3	19.9	109	19.9	109	2	2.9	15.3
	400	50	106	150	125	125	21.8	140	21.8	140	2	3.4	17.5	21.8	140	21.8	140	2	3.4	17.5
	200	60	268	400	300	300	55.8	425	55.8	425	2	7.6	44.0	55.8	425	55.8	425	2	7.6	44.0
0065	230	60	267	400	300	300	55.8	425	55.8	425	2	7.4	19.1	55.8	425	55.8	425	2	7.4	19.1
	380	60	171	200	200	200	36.0	239	36.0	239	2	4.5	23.1	36.0	239	36.0	239	2	4.5	23.1
	460	60	130	150	150	150	26.9	187	26.9	187	2	4.0	19.0	26.9	187	26.9	187	2	4.0	19.0
	575	60	112	150	125	125	23.7	148	23.7	148	2	2.9	15.3	23.7	148	23.7	148	2	2.9	15.3
	400	50	114	150	125	125	23.7	198	23.7	198	2	3.4	17.5	23.7	198	23.7	198	2	3.4	17.5
	200	60	324	400	350	400	76.9	505	76.9	505	2	7.6	30.9	59.9	425	59.9	425	2	7.6	30.9
	230	60	301	400	350	350	71.2	505	71.2	505	2	7.4	37.0	55.5	425	55.5	425	2	7.4	37.0
0072	380	60	175	200	200	200	41.1	280	41.1	280	2	4.5	22.3	32.0	239	32.0	239	2	4.5	22.3
	400	50	146	200	175	175	33.9	225	33.9	225	2	4.0	19.0	26.4	198	26.4	198	2	4.0	19.0
	460	60	143	200	175	175	33.9	225	33.9	225	2	3.4	17.2	26.4	187	26.4	187	2	3.4	17.2
	575	60	115	150	125	125	27.1	180	27.1	180	2	2.9	14.6	21.1	148	21.1	148	2	2.9	14.6
	400	50	146	200	175	175	33.9	225	33.9	225	2	4.0	19.0	26.4	198	26.4	198	2	4.0	19.0
	200	60	324	400	350	400	76.9	505	76.9	505	2	7.6	30.9	59.9	425	59.9	425	2	7.6	30.9

See Notes on page 35.

Electrical Data - 50 & 60Hz - continued

UNIT VOLTAGE	UNIT VOLTAGE	CONTROL POWER	MCA	OVER CURRENT PROTECTION, SEE NOTE B		NF DISC Sw
				MIN	MAX	
MODELS w/o CONTROL TRANS		115-1-60/50	15A	10A	15A	30 A / 240V
MODELS w/ CONTROL TRANS	-17	200-1-60	15A	10A	15A	30 A / 240V
	-28	230-1-60	15A	10A	15A	30 A / 240V
	-40	380-1-60	15A	10A	15A	30 A / 480V
	-46	460-1-60	15A	10A	15A	30 A / 480V
	-50	380/415-1-50	15A	10A	15A	30A / 415V
	-58	575-1-60	15A	10A	15A	30 A / 600V

A. Minimum #14 AWG, 75°C, Copper Recommended

B. Minimum and Maximum Over Current Protection, Dual Element Fuse or Circuit Breaker

VOLTAGE RANGE			
VOLTAGE CODE	UNIT POWER	MIN.	MAX.
-17	200-3-60	180	220
-28	230-3-60	207	253
-40	380-415-3-60	342	440
-46	460-3-60	414	506
-50	380-415-3-50	342	440
-58	575-3-60	517	633

LEGEND

ACR	LINE ACROSS THE LINE START
C.B.	CIRCUIT BREAKER
D.E.	DUAL ELEMENT FUSE
DISC SW	DISCONNECT SWITCH
FACT MOUNT CB	FACTORY MOUNTED CIRCUIT BREAKER
FLA	FULL LOAD AMPS
HZ	HERTZ
MAX	MAXIMUM
MCA	MINIMUM CIRCUIT AMPACITY
MIN	MINIMUM
MIN	NF MINIMUM NON FUSED
RLA	RATED LOAD AMPS
S.P. WIRE	SINGLE POINT WIRING
UNIT MTD SERV SW	UNIT MOUNTED SERVICE (NON-FUSED DISCONNECT SWITCH)
LRA	LOCKED ROTOR AMPS

Electrical Notes

NOTES:

1. Minimum Circuit Ampacity (MCA) is based on 125% of the rated load amps for the largest motor plus 100% of the rated load amps for all other loads included in the circuit, per N.E.C. Article 43024. If the optional Factory Mounted Control Transformer is provided, add the following MCA values to the electrical tables for the system providing power to the transformer: 17, add 2.5 amps; 28, add 2.3 amps; 40, add 1.5 amps, 46, add 1.3 amps; 58, add 1 amps.
2. The minimum recommended disconnect switch is based on 115% of the rated load amps for all loads included in the circuit, per N.E.C. Article 440.
3. Minimum fuse size is based upon 150% of the rated load amps for the largest motor plus 100% of the rated load amps for all other loads included in the circuit to avoid nuisance trips at startup due to lock rotor amps. It is not recommended in applications where brown outs, frequent starting and stopping of the unit, and/or operation at ambient temperatures in excess of 95°F (35°C) is anticipated.
4. Maximum fuse size is based upon 225% of the rated load amps for the largest motor plus 100% of the rated load amps for all other loads included in the circuit, per N.E.C. Article 440-22.
5. Circuit breakers must be UL listed and CSA certified and maximum size is based on 225% of the rated load amps for the largest motor plus 100% of the rated load amps for all other loads included in the circuit. Otherwise, an HACR type circuit breakers must be used. Maximum HACR circuit breaker rating is based on 225% of the rated load amps for the largest motor plus 100% of the rated load amps for all other loads included in the circuit.
6. The "INCOMING WIRE RANGE" is the minimum and maximum wire size that can be accommodated by the unit wiring lugs. The (2) preceding the wire range indicates the number of termination points available per phase of the wire range specified. Actual wire size and number of wires per phase must be determined based on the National Electrical Code, using copper connectors only. Field wiring must also comply with local codes.
7. A ground lug is provided for each compressor system to accommodate a field grounding conductor per N.E.C. Table 25095. A control circuit grounding lug is also supplied.
8. The supplied disconnect is a "Disconnecting Means" as defined in the N.E.C. 100, and is intended for isolating the unit for the available power supply to perform maintenance and troubleshooting. This disconnect is not intended to be a Load Break Device.
9. Field Wiring by others which complies to the National Electrical Code & Local Codes.

Circuit Breaker Calculations

MAX DUAL ELEM FUSE MAX CB (MOP)
 = 2.25 X CURRENT OF LARGEST MOTOR + \sum (REMAINING FLAS OR RLAS)

FOR THIS NAME PLATE THE FORMULA BELOW WAS USED:
 = 2.25 * RLACPR1 + RLACPR2 + RLACPR3 + QTY* RLAFANS + 0.49 + FLAPUMP

THIS FORMULA WILL CALCULATE THE ACTUAL MOP BUT A TABLE IS REFERENCED TO PROVIDE THE APPROPRIATE MOP.

ACTUAL COLUMN A	MINIMUM COLUMN B*	MAXIMUM COLUMN C
0	15	0
15	20	15
20	25	20
25	30	25
30	35	30
35	40	35
40	45	40
45	50	45
50	60	50
60	70	60
70	80	70
80	90	80
90	100	90
100	110	100
110	125	110
125	150	125
150	175	150
175	200	175
200	225	200
225	250	225
250	300	250
300	350	300
350	400	350

USING AN APPROXIMATE MATCH, LOOK UP THE VALUE OF THE CALCULATED ACTUAL MOP IN COLUMN A. FIND THE LARGEST VALUE I.E. LESS THAN OR EQUAL TO THE VALUE IN COLUMN A. ONCE FOUND, THE VALUE IN COLUMN C WHICH SHARES THE SAME ROW IS THE VALUED USED IN THE SYSTEM. E.G. E.G. USING THE SAME EXAMPLE THAT WAS USED TO CALCULATE THE MCA, CALCULATE THE MOP:ANS. ACTUAL = 2.25*20.4 + 20.4 + 0 + 2*2.6 + 5.29
 = 45.9 + 30.89 = 76.79
 COMPARING AGAINST VALUES IN COLUMN A: 70 < 76.79 < 80, THEREFORE THE USED MOP FOUND IN COLUMN C IS 70.

(*NOTE: COLUMN B IS USED IF ONE WERE CALCULATING THE MINIMUM DUAL ELEM FUSE WHICH IS NOT RELEVANT TO THIS EXERCISE.)

Application Data

UNIT LOCATION

The YCUL Condensing Units are designed for outdoor installation. When selecting a site for installation, be guided by the following conditions:

1. For outdoor locations of the unit, select a place having an adequate supply of fresh air for the condenser.
2. Avoid locations beneath windows or between structures where normal operating sounds may be objectionable.
3. Installation sites may be either on a roof, or at ground level. (See **FOUNDATION**, below.)
4. The condenser fans are the propeller-type, and are not recommended for use with duct work in the condenser air stream.
5. When it is desirable to surround the unit(s), it is recommended that the screening be able to pass the required chiller CFM without exceeding 0.1" of water external static pressure.
6. Protection against corrosive environments is available by supplying the units with either copper fin, cured phenolic, or epoxy coating on the condenser coils. The phenolic or epoxy coils should be offered with any units being installed at the seashore or where salt spray may hit the unit.

In installations where winter operation is intended and snow accumulations are expected, additional height must be provided to ensure normal condenser air flow.

Recommended clearances for units are given in **DIMENSION DRAWINGS**. When the available space is less, the unit(s) must be equipped with the discharge pressure transducer option to permit high pressure unloading in the event that air recirculation were to occur.

FOUNDATION

The unit should be mounted on a flat and level foundation, ground or roof, capable of supporting the entire operating weight of the equipment. Operating weights are given in the **PHYSICAL DATA** tables.

Roof Locations – Choose a spot with adequate structural strength to safely support the entire weight of the unit and service personnel. Care must be taken not to damage the roof during installation. If the roof is “bonded”, consult the building contractor or architect for special installation requirements. Roof installations should incorporate the use of spring-type isolators to minimize the transmission of vibration into the building structure.

Ground Level Installations – It is important that the units be installed on a substantial base that will not settle, causing strain on the refrigerant lines and resulting in possible leaks. A one-piece concrete slab with footers extending below the frost line is highly recommended, particularly in areas where winters are long and very cold. Additionally, the slab should not be tied to the main building foundation as noises will telegraph.

Mounting holes (11/16" diameter) are provided in the steel channel for bolting the unit to its foundation. See **DIMENSION DRAWINGS**.

For ground level installations, precautions should be taken to protect the unit from tampering by or injury to unauthorized persons. Screws on access panels will prevent casual tampering; however, further safety precautions, such as unit enclosure options, a fenced-in enclosure, or locking devices on the panels may be advisable. Check local authorities for safety regulations.

REFRIGERANT PIPING

When sizing refrigerant pipe for split system air conditioning, consideration must be given to the: (1) Suction line pressure drop due to friction, (2) Liquid line pressure drop due to friction, (3) Suction line velocity for oil return, and (4) Liquid line pressure drop due to vertical rise. Refer to **DESIGN PARAMETERS** for friction losses for both the suction and liquid lines for the condensing unit.

On a system where the evaporator blower is located below the condensing unit, the suction line must be sized for both pressure drop and oil return.

When the condensing unit is located below the evaporator blower, the liquid line must be designed for pressure drop due to friction loss and vertical rise. If the pressure drop due to vertical rise and friction loss exceeds 30 psig (2.1 barg), some refrigerant will flash before it reaches the thermal expansion valve.

All horizontal suction lines should be pitched at least 1/4 inch (6 mm) per foot in the direction of the refrigerant flow to aid the return of oil to the compressor. All suction lines with a vertical rise exceeding 3 feet (1 m) should have a ‘P’ trap at the bottom and the top to facilitate oil return. Suction lines with a vertical rise exceeding 25 feet (7.6 m) should be trapped every 15 feet (4.6 m) to provide drain points for the oil when the circuit is deactivated. When the circuit is reactivated, oil will return to the compressor more quickly and in smaller slugs.

For more details, refer to ASHRAE Refrigeration Handbook, System Practices for Halocarbon Refrigerants.

Guide Specifications

PART 1 – GENERAL

1.01 SCOPE

- A. The requirements of the General Conditions, Supplementary Conditions, Division 1, and Drawings apply to all Work herein.
- B. Provide Microprocessor controlled, multiple-scroll compressor, air-cooled, condensing units of the scheduled capacities as shown and indicated on the Drawings, including but not limited to:
 - 1. Condensing Unit package
 - 2. Electrical power and control connections
 - 3. DX Central Station Air Handling connections

1.02 QUALITY ASSURANCE

- A. Products shall be Designed, Tested, and installed in compliance with applicable sections of the following Standards and Codes:
 - 1. ANSI/ASHRAE Standard 15 – *Safety Code for Mechanical Refrigeration*
 - 2. ASHRAE 90.1 - *Energy efficiency compliance.*
 - 3. ANSI/NFPA Standard 70 – *National Electrical Code (N.E.C.)*.
 - 4. Conform to Intertek Testing Services, formerly ETL, for construction of condensing units and provide E.T.L./c E.T.L. Listing label.
 - 5. Manufactured in facility registered to ISO 9002.
- B. Factory Test: Condensing Unit shall be pressure tested, evacuated and given a nitrogen holding charge and an initial oil charge, and shall be factory operational run tested to assure each control device operates properly.
- C. Warranty: Manufacturer shall Warrant all equipment and material of its manufacture against defects in workmanship and material for a period of one year from date of initial start-up or eighteen (18) months from date of shipment, whichever occurs first.

1.03 DELIVERY AND HANDLING

- A. Unit shall be delivered to job site fully assembled, and given nitrogen holding charge and a full oil charge by the Manufacturer. (R-410A refrigerant supplied by others).
- B. Unit shall be stored and handled per Manufacturer's instructions.

PART 2 - PRODUCTS

2.01 CONDENSING UNITS MATERIALS APONENTS

- A. General: Install and commission, as shown on the schedules and plans, factory assembled, charged,

and tested air cooled scroll compressor condensing unit as specified herein. Condensing Unit shall be designed, selected, and constructed using a refrigerant with Flammability rating of "1", as defined by ANSI/ASHRAE STANDARD - 34 *Number Designation and Safety Classification of Refrigerants*. Condensing Unit shall include, but is not limited to: not less than two refrigerant circuits, scroll compressors, air-cooled condenser, refrigerant, lubrication system, interconnecting wiring, safety and operating controls including capacity controller, control center, motor starting components, and special features as specified herein or required for safe, automatic operation.

- B. Cabinet: External structural members shall be constructed of heavy gauge, galvanized steel coated with baked on powder paint which, when subject to ASTM B117, 1000 hour, 5% salt spray test, yields minimum ASTM 1654 rating of "6".

2.02 COMPRESSORS

- A. Compressors: Shall be hermetic, scroll-type, including:
 - 1. Compliant design for axial and radial sealing.
 - 2. Refrigerant flow through the compressor with 100% suction cooled motor.
 - 3. Large suction side free volume and oil sump to provide liquid handling capability.
 - 4. Compressor crankcase heaters to provide extra liquid migration protection.
 - 5. Annular discharge check valve and reverse vent assembly to provide low pressure drop, silent shutdown and reverse rotation protection.
 - 6. Initial Oil charge.
 - 7. Oil Level sightglass.
 - 8. Vibration isolator mounts for compressors.
 - 9. Brazed-type connections for fully hermetic refrigerant circuits.

2.03 REFRIGERANT CIRCUIT

Two independent refrigerant circuits will be furnished on each unit. All unit piping will be copper, with brazed joints. The liquid line will include a field connection shutoff valve with charging port located on each condenser circuit. Suction line connections are provided on each refrigeration circuit. Filter drier and sight glass are shipped loose for field installation on each refrigerant circuit. All expansion valves and liquid line solenoid valves and refrigerant field piping are supplied by others.

2.04 HEAT EXCHANGERS

- A. Air Cooled Condenser:

1. Coils: Internally enhanced, seamless copper tubes, mechanically expanded into aluminum alloy fins with full height collars. Subcooling coil an integral part of condenser. Design working pressure shall be 650 psig (45 barg).
2. Fans: Shall be dynamically and statically balanced, direct drive, corrosion resistant glass fiber reinforced composite blades molded into low noise, full airfoil cross section, providing vertical air discharge from extended orifices for efficiency and low sound. Each fan in its own compartment to prevent cross flow during fan cycling. Guards of heavy gauge PVC (polyvinyl chloride) coated steel.
3. Fan Motors: High efficiency, direct drive, 6 pole, 3 phase, insulation class "F", current-protected, Totally Enclosed Air-Over (TEAO), rigid mounted, with double sealed, permanently lubricated, ball bearings.

2.05 CONTROLS

- A. General: Automatic start, stop, operating, and protection sequences across the range of scheduled conditions and transients.
 - B. Microprocessor Enclosure: Rain and dust tight NEMA 3R/12 (IP55) powder painted steel cabinet with hinged, latched, and gasket sealed door.
 - C. Microprocessor Control Center:
 1. Condensing Unit control is set for Discharge Air Temperature Control
 2. Automatic control of compressor start/stop, anti-coincidence and anti-recycle timers, automatic pump-down shut-down, condenser fans, unit alarm contacts, and condensing unit operation from 0°F to 125°F (-18°C to 52°C) ambient. Automatic reset to normal chiller operation after power failure.
 3. Software stored in non-volatile memory, with programmed set-points retained in lithium battery-backed real time clock (RTC) memory for minimum 5 years.
 4. Forty character liquid crystal display, descriptions in English (or Spanish, French, Italian, or German), numeric data in English (or Metric) units. Sealed keypad with sections for Setpoints, Display/Print, Entry, Unit Options & clock, and On/Off Switch.
 5. Programmable Set-points (within Manufacturer limits): display language; suction pressure setting and control range, remote reset temperature
 - D. Manufacturer shall provide any controls not listed above, necessary for automatic condensing unit operation. Mechanical Contractor shall provide field control wiring necessary to interface sensors to the condensing unit control system.
- range, set daily schedule/holiday for start/stop, manual override for servicing, low and high ambient cutouts, number of compressors, low suction pressure cutout, high discharge pressure cutout, anti-recycle timer (compressor start cycle time), and anticoincident timer (delay compressor starts).
 6. Display Data: Suction temperatures (optional), low ambient temperature cutout setting, outdoor air temperature, English or metric data, suction pressure cutout setting, each system suction pressure, discharge pressure (optional), discharge air reset via Building Automation System (by others) via a 4-20milliamp or 0-10 VDC input with optional BAS interface, anti-recycle timer status for each system, anti-coincident system start timer condition, compressor run status, no cooling load condition, day, date and time, daily start/stop times, holiday status, automatic or manual system lead/lag control (when controlling based on Discharge Air Temperature only), automatic lead/lag of compressors within a system, compressor starts/operating hours (each), status of hot gas valves, and fan operation, run permissive status, number of compressors running, liquid solenoid valve status, load & unload timer status.
 7. System Safeties: Shall cause individual compressor systems to perform auto shut down; manual reset required after the third trip in 90 minutes. Includes: high discharge pressure, low suction pressure, high pressure switch, and motor protector. Compressor motor protector shall protect against damage due to high input current or thermal overload of windings.
 8. Unit Safeties: Shall be automatic reset and cause compressors to shut down if low ambient, or under voltage.
 9. Alarm Contacts: Low ambient, low voltage, low battery, and (per compressor circuit): high discharge pressure, and low suction pressure.
 10. High Ambient Control: Permits unit operation above 115°F (46°C) ambient.

2.06 POWER CONNECTION AND DISTRIBUTION

- A. Power Panels:
 1. NEMA 3R/12 (IP55) rain/dust tight, powder painted steel cabinets with hinged, latched, and

Guide Specifications – continued

gasket sealed outer doors. Provide main power connection(s), control power connections, compressor and fan motor start contactors, current overloads, and factory wiring.

2. Power supply shall enter unit at a single location, be 3 phase of scheduled voltage, and connect to individual terminal blocks per compressor. Separate disconnecting means and/or external branch circuit protection (by Contractor) required per applicable local or national codes.

- B. Exposed compressor, control and fan motor power wiring shall be routed through liquid tight conduit.

2.07 ACCESSORIES AND OPTIONS

Some accessories and options supercede standard product features. Your YORK representative will be pleased to provide assistance.

- A. Microprocessor controlled, Factory installed Across-the-Line type compressor motor starters as standard.

- B. Outdoor Ambient Temperature Control

1. Low Ambient Control: Permits unit operation to 0°F (-18°C) ambient. Standard unit controls to 32°F (0°C) ambient.

- C. Power Supply Connections:

1. Single Point Power Supply: Single point Terminal Block for field connection and interconnecting wiring to the compressors. Separate external protection must be supplied, by others, in the incoming power wiring, which must comply with the National Electric Code and/or local codes.
2. Single Point: Single point Non-Fused Disconnect(s) and lockable external handle (in compliance with Article 440-14 of N.E.C.) can be supplied to isolate the unit power voltage for servicing. Separate external fusing must be supplied, by others, in the incoming power wiring, which must comply with the National Electric Code and/or local codes.
3. Single Point Circuit Breaker: Single point Terminal Block with Circuit Breaker and lockable external handle (in compliance with Article 440-14 of N.E.C.) can be supplied to isolate power voltage for servicing. Incoming power wiring must comply with the National Electric Code and/or local codes.

- D. Pressure & Temperature Transducers and Sensors

1. Discharge Pressure Transducers: Permits unit to

sense and display discharge pressure.

2. Suction Pressure Transducers: Permits unit to sense and display suction pressure.

- E. Control Power Transformer: Converts unit power voltage to 120-1-60 (500 VA capacity). Factory mounting includes primary- and secondary-wiring between the transformer and the control panel.

- F. Motor Current Module: Capable of monitoring compressor motor current. Provides extra protection against compressor reverse rotation, phase-loss and phase imbalance. Options consists of one module per electrical system. (Factory mounted)

- G. Power Factor Correction Capacitors: Provided to correct unit compressor factors to a 0.90-0.95.

- H. Condenser Coil Environmental Protection:

1. Pre-Coated: Epoxy coated aluminum fin stock to guard from corrosive agents and insulate against galvanic potential. For mild seashore or industrial locations
2. Copper Fin: Provide copper fins in lieu of aluminum.
3. Post-Coated Dipped: Dipped-cured coating on condenser coils for seashore and other corrosive applications (with the exception of strong alkalis, oxidizers, and wet bromine, chlorine and fluorine in concentrations greater than 100ppm).

- I. Protective Condensing Unit Panels (Factory or Field Mounted):

1. Wire Panels (full unit): Heavy gauge, welded wire-mesh, coated to resist corrosion, to protect condenser coils from incidental damage and restrict unauthorized access to internal components.
2. Louvered Panels (full unit): Painted steel as per remainder of unit cabinet, to protect condenser coils from incidental damage, visually screen internal components, and prevent unauthorized access to internal components.

- J. Service Isolation valves: Service suction and discharge (ball type) isolation valves are added to unit per system. This option also includes a system high pressure relief valve in compliance with ASHRAE15. (Factory-mounted.)

- K. Hot Gas By-Pass: Permits continuous, stable operation at capacities below the minimum step of unloading to as low as 5% capacity (depending on both the unit & operating conditions) by introducing an artificial load. Hot gas by-pass is available installed on one or

both refrigerant circuit(s).

- L. Microprocessor Membrane Keypad Graphics on in lieu of Standard English:
 1. French language.
 2. German language.
 3. Spanish language.
 4. Italian language.
- M. Chicago Code Relief Valves to meet Chicago Code requirements.
- N. Building Automation System (EMS) Reset Interface: Condensing Unit to accept 4 to 20mA, 0 to 10 VDC, input to reset the discharge air temperature.
- O. Sound Reduction (Factory Mounted):
 1. Low speed, reduced noise fans
 2. Compressor Acoustic Sound Blankets
- P. Vibration Isolation (Field Mounted):
 1. Neoprene Pad Isolators.
 2. 1 Inch Deflection Spring Isolators: Level adjustable, spring and cage type isolators for mounting under the unit base rails.
 3. 2 Inch Deflection Seismic Isolators: Level adjustable, restrained mounts in rugged welded steel housing with vertical and horizontal limit stops. Housings shall be designed to withstand a mini-

mum 1.0g accelerated force in all directions to 2 inches.

PART 3 - EXECUTION

3.01 INSTALLATION

- A. General: Rig and Install in full accordance with Manufacturers requirements, Project drawings, and Contract documents.
- B. Location: Locate condensing unit as indicated on drawings, including cleaning and service maintenance clearance per Manufacturer instructions. Adjust and level condensing unit on support structure.
- C. Components: Installing Contractor shall provide and install all auxiliary devices and accessories for fully operational condensing unit.
- D. Electrical: Coordinate electrical requirements and connections for all power feeds with Electrical Contractor (Division 16).
- E. Controls: Coordinate all control requirements and connections with Controls Contractor.
- F. Finish: Installing Contractor shall paint damaged and abraded factory finish with touch-up paint matching factory finish.

Printed on recycled paper

Form 150.68-EG1 (509) New Release

© 2008 Johnson Controls, Inc. P.O. Box 423, Milwaukee, WI 53201 Printed in USA
www.johnsoncontrols.com

