



TECHNICAL GUIDE

SINGLE PIECE ECM AIR HANDLERS

FOR USE WITH SPLIT-SYSTEM
AIR CONDITIONERS & HEAT PUMPS

MODELS: AHV18 THRU 60



Due to continuous product improvement, specifications are subject to change without notice.

Visit us on the web at:

www.york.com

Additional rating information can be found at:

www.ahridirectory.org

WARRANTY

Standard 5-year limited parts warranty.

Extended 10-year limited parts warranty when product is registered online within 90 days of purchase for replacement or closing for new home construction.

DESCRIPTION

The AHV Air Handler line offers the ultimate in comfort, sound and application flexibility. The air handler is shipped ready to be installed in upflow, horizontal left or right position, with minor adjustments. No special kits are required to install this deluxe product.

Air handlers are shipped with "Flex-coils" without a factory installed metering device. Flex coil models allow these coils to be used with R-22 or R-410A for added flexibility to meet refrigerant choices. An orifice metering device or a R-410A TXV should be installed in the field to meet your system requirements.

FEATURES

Thermostatic Expansion Valve - Provides the ultimate refrigerant control required for today's high efficient product. The UPG bolt-on TXV provides easy installation to convert the air handler to the required refrigerant, which is a true bolt-on design that does not require brazing to replace or install.

Rust-proof Plastic Drain Pans - The vertical and horizontal drain pans in these units are made of a fiberglass reinforced thermoset polymer that will not rust or compromise stability at high temperatures.

Insulated Cabinet - All air handler cabinets are thermally insulated with 3/4" foil faced insulation to prevent sweating.

Factory Sealed - Achieves 2% or less total airflow leakage rate at duct leakage test conditions for system airflow verification.

Durable Finish Inside and Out - Air handler casings are made of pre-painted galvanized steel which provides a better paint to steel bond that resists corrosion and rust creep. All internal coil sheet metal parts are made of G60 galvanized or prepainted G30 galvanized steel.

Filters - All models have internal filter racks provided for use with 1" thick standard size filters.

Electric Heat Kits - The 6HK series of field installed electric heat kits are available for installation friendly and easy service applications. These 6HK kits have heat capacities from 2 kW to 25 kW to meet the application requirements.

ECM Variable Speed Motor - Designed for efficient, quiet operation with added indoor comfort control. With the use of a humidistat, the system will monitor the humidity in the home and automatically keep the desired humidity level in both winter and summer seasons. The ECM motor utilizes only 24% of the energy used by standard blower motors to reduce your overall heating and cooling costs.

The climate comfort system allows dealer to customize comfort settings based on regional location.

Communications - These models may be connected as part of a communications system using a 4-wire connection bus.

DIMENSIONS & DUCT CONNECTION DIMENSIONS

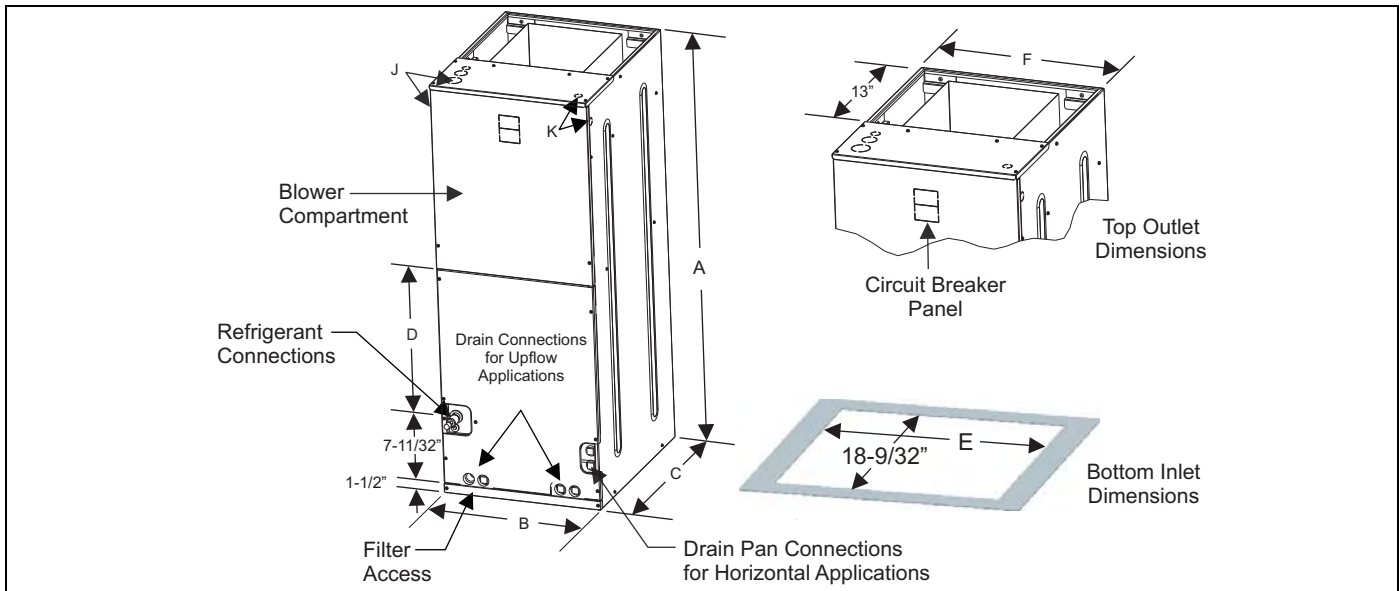

Dimensions¹

Models	Dimensions						Wiring Knockouts ²		Refrigerant Connections Line Size	
	A	B	C	D	E	F	J	K	Liquid	Vapor
	Height	Width	Depth				Power	Control		
AHV18B/AHV24B/AHV30B	46	17 1/2	21 1/2	16 1/2	13-29/32	16 1/2	7/8 (1/2)	7/8 (1/2)	3/8	3/4
AHV36C	52	21		21 1/2	17-13/32	20	1-3/8(1)			
AHV42D/AHV48D/AHV60D	57	24 1/2		26	20-29/32	23-1/2	1-23/32 (1-1/4)			

1. All dimensions are in inches.
 2. Actual size (conduit size).

COIL TECHNICAL DATA

Models	Application	Refrig. Conn. Types	Face Area (Sq. Ft.)	Rows Deep	Fins Per In.	Coil Size	Tube Geometry	Tube Dia.	Fin Type
AHV18B3XH21	Cooling /Heat Pump	Sweat	3.4	2	14	(2) 14 x 17.5	1 x 0.866	3/8	Enhanced
AHV24B3XH21	Cooling /Heat Pump	Sweat	3.9	3	12	(2) 16 x 17.5	1 x 0.866	3/8	Enhanced
AHV30B3XH21	Cooling /Heat Pump	Sweat	3.9	3	12	(2) 16 x 17.5	1 x 0.866	3/8	Enhanced
AHV36C3XH21	Cooling /Heat Pump	Sweat	4.9	3	12	(2) 20 x 17.5	1 x 0.866	3/8	Enhanced
AHV42D3XH21	Cooling /Heat Pump	Sweat	5.4	3	12	(2) 22 x 17.5	1 x 0.866	3/8	Enhanced
AHV48D3XH21	Cooling /Heat Pump	Sweat	5.8	3	11	(2) 24 x 17.5	1 x 0.866	3/8	Enhanced
AHV60D3XH21	Cooling /Heat Pump	Sweat	6.8	3	12	(2) 28 x 17.5	1 x 0.866	3/8	Enhanced

COOLING CAPACITY¹

Models	Rated CFM ²	Entering Air Dry/Wet Bulb (°F)	MBH@ Evap. Temp. and Corresponding R-410A Pressure (°F/PSIG)			
			35/107.9	40/118.9	45/130.7	50/143.3
AHV18B	610	85/72	37.9	33.7	28.3	23.3
		80/67	31.8	27	22.5	17.6
		75/62	26.4	21.5	16.7	11.6
		70/57	20.7	18.4	15.8	13.5
	850	85/72	49.7	43.2	36.9	28.4
		80/67	42.1	35.1	28.8	22.5
		75/62	33.7	28	21.4	14.7
		70/57	26.5	23.8	20.3	16.9
AHV24B	585	85/72	38.7	34.4	30.1	24.7
		80/67	33.6	28.9	23.9	18.9
		75/62	27.2	22.7	17.8	12.8
		70/57	21.2	18.6	16.2	13.7
	795	85/72	50.8	45.2	38.4	32.0
		80/67	43.7	36.8	31	24.0
		75/62	35.7	29.5	23.1	16.1
		70/57	27.9	24.5	21	17.6
	985	85/72	64.9	54	45.6	37.8
		80/67	52.3	44.6	36.9	28.4
		75/62	42.2	35.2	26.8	19.3
		70/57	33.6	29.6	25.4	21.4
AHV30B	585	85/72	38.7	34.4	30.1	24.7
		80/67	33.6	28.9	23.9	18.9
		75/62	27.2	22.7	17.8	12.8
		70/57	21.2	18.6	16.2	13.7
	795	85/72	50.8	45.2	38.4	32.0
		80/67	43.7	36.8	31	24.0
		75/62	35.7	29.5	23.1	16.1
		70/57	27.9	24.5	21	17.6
	985	85/72	64.9	54	45.6	37.8
		80/67	52.3	44.6	36.9	28.4
		75/62	42.2	35.2	26.8	19.3
		70/57	33.6	29.6	25.4	21.4
AHV36C	730	85/72	49.3	45.2	38.3	31.4
		80/67	43	37.3	31	24.0
		75/62	34.7	28.8	22.8	16.2
		70/57	26.8	23.4	20.4	16.9
	855	85/72	59.1	51	44.1	36.5
		80/67	49.3	42.4	35.4	27.6
		75/62	39.9	33.1	26.1	18.2
		70/57	31.1	26.9	23.5	19.7
	1000	85/72	65.2	59.5	51.2	41.3
		80/67	56.4	48.3	39.9	31.3
		75/62	45.8	38.1	29.7	20.8
		70/57	35.7	31.2	26.9	22.6
	1190	85/72	67.5	65.9	59.8	48.7
		80/67	64.9	56.7	46.2	35.7
		75/62	53.5	43.2	34.1	24.0
		70/57	41.4	36.6	31.5	26.2

For notes see Page 4.

COOLING CAPACITY¹ (Continued)

Models	Rated CFM ²	Entering Air Dry/Wet Bulb (°F)	MBH@ Evap. Temp. and Corresponding R-410A Pressure (°F/PSIG)			
			35/107.9	40/118.9	45/130.7	50/143.3
AHV42D	820	85/72	56.6	51.1	42.8	35.6
		80/67	48.6	41.1	34.8	27.6
		75/62	39.4	33	26	18.3
		70/57	30.5	26.6	23.1	19.6
	1000	85/72	65.7	61	52.7	42.9
		80/67	58	49.6	41.1	32.1
		75/62	46.7	38.9	30.4	21.8
		70/57	36.4	31.6	27.6	23.3
	1180	85/72	67.9	71.4	60.2	48.8
		80/67	65.6	56.9	47.1	37.1
		75/62	53.8	45.2	34.7	24.6
		70/57	42.2	37.1	31.9	27.0
	1385	85/72	69.4	81	68	57.2
		80/67	77.1	65.4	54.1	41.6
		75/62	62.1	51	39.8	28.1
		70/57	48.1	42.5	36.8	30.6
AHV48D	1000	85/72	69	59.8	51.3	41.5
		80/67	56.5	48.2	39.7	29.9
		75/62	45.1	36.8	28.3	18.9
		70/57	34.4	31	26.8	22.5
	1195	85/72	79.5	69.7	59.9	48.6
		80/67	65.2	55.5	45.5	34.9
		75/62	52.2	42.5	32.6	21.8
		70/57	40.1	36.1	31.1	26.2
	1385	85/72	90	78.1	66	54.5
		80/67	73.5	62.7	51.3	38.7
		75/62	59.2	48.2	36.9	24.0
		70/57	45.2	41	35.4	29.7
	1600	85/72	102.2	90	74.3	60.4
		80/67	83.6	70.6	57.2	43.1
		75/62	66.1	54	41.2	27.0
		70/57	50.7	46.1	39.8	33.4
AHV60D	1190	85/72	83.6	73.7	62.9	51.6
		80/67	68.2	58.4	48.4	37.1
		75/62	54.9	45.3	34.8	23.9
		70/57	42.2	37.3	31.9	26.9
	1390	85/72	95.9	84.1	71.9	58.8
		80/67	79.2	67.4	54.4	41.6
		75/62	62.4	51.2	39.7	26.9
		70/57	48	42.5	36.8	30.6
	1565	85/72	106.3	94.2	78.5	63.5
		80/67	87.6	73.9	60.2	45.9
		75/62	69.3	56.8	43.5	29.7
		70/57	53.1	46.9	40.5	34.1
	1835	85/72	122.1	107.1	90.9	72.6
		80/67	100.2	85.9	69.8	51.8
		75/62	79.7	65.3	49.8	32.9
		70/57	60.8	54.1	46.4	38.7

1. Actual capacity varies with the outdoor AC or HP that is used with the system.

2. Airflow is calculated for each system tonnage.

APPLICATION FACTORS - RATED CFM VS. ACTUAL CFM

% Of Rated Airflow (CFM)	80%	90%	100%	110%	120%
Capacity Factor	0.96	0.98	1.00	1.02	1.03

PHYSICAL & ELECTRICAL DATA - COOLING ONLY

MODELS							
Models	18B	24B	30B	36C	42D	48D	60D
Blower - Diameter x Width	10 x 8	10 x 8	10 x 8	11 x 10	11 x 10	11 x 10	11 x 10
Motor	HP	1/3 HP	1/3 HP	1/3 HP	1/2 HP	1/2 HP	3/4 HP
	Nominal RPM	1050	1050	1050	1050	1050	1050
Voltage	208/230	208/230	208/230	208/230	208/230	208/230	208/230
Full Load Amps @230V	2.3	2.3	2.3	3.2	3.2	4.9	4.9
Filter ¹	Type	DISPOSABLE OR PERMANENT					
	Size	16 x 20 x 1	16 x 20 x 1	16 x 20 x 1	20 x 20 x 1	22 x 20 x 1	22 x 20 x 1
	Permanent Type Kit	1PF0601BK	1PF0601BK	1PF0601BK	1PF0602BK	1PF0603BK	1PF0603BK
Shipping / Operating Weight (bs.)	116/104	121/106	121/106	153/138	169/151	172/154	175/157

1. Field supplied.

KW & MBH CONVERSIONS - FOR TOTAL POWER INPUT REQUIREMENT

For a power distribution voltage that is different than the provided nominal voltage, multiply the kW and MBH data from the table by the conversion factor in the following table.

DISTRIBUTION POWER	NOMINAL VOLTAGE	CONVERSION FACTOR
208V	240V	0.75
220V	240V	0.84
230V	240V	0.92

ELECTRICAL DATA - COOLING ONLY

Models	Motor FLA ¹		Minimum Circuit Ampacity		MOP ²	Minimum Wire Size (AWG) ³
	208V	230V	208V	230V		
18B 24B 30B	2.7	2.3	3.4	2.9	15	14
36C 42D	3.6	3.2	4.5	4.0	15	14
48D 60D	5.3	4.9	6.6	6.1	15	14

1. FLA = Full Load Amps.

2. MOP = Maximum Overcurrent Protection device; must be HACR type circuit breaker or time delay fuse.

3. 75 C, copper wire only. If wire other than non-plated, 75 C ambient, copper wire is used, consult applicable tables of the NEC and local codes..

ELECTRICAL HEAT: MINIMUM FAN SPEED¹

Heater Kit Models ^{2,3}	Nom. kW @240V	Air Handler Models						
		AHV18B	AHV24B	AHV30B	AHV36C	AHV42D	AHV48D	AHV60D
6HK(0,1)6500206	2.4kW	Low (D)	Low (D)	Low (D)	Low (D)	Low (D)	Low (D)	Low (D)
6HK(0,1)6500506	4.8kW	Low (D)	Low (D)	Low (D)	Low (D)	Low (D)	Low (D)	Low (D)
6HK(0,1)6500806	7.7kW	Med-Low (C)	Low (D)	Low (D)	Low (D)	Low (D)	Low (D)	Low (D)
6HK(0,1)6501006 6HK06501025	9.6kW	Med-Low (C)	Low (D)	Low (D)	Low (D)	Low (D)	Low (D)	Low (D)
6HK(1,2)6501306	12.5kW	-	Med-Low (C)	Med-Low (C)	Low (D)	Low (D)	Low (D)	Low (D)
6HK(1,2)6501506 6HK06501525	14.4kW	-	Med-Low (C)	Med-Low (C)	Med-Low (C)	Low (D)	Low (D)	Low (D)
6HK(1,2)6501806 6HK06501825	17.3kW	-	-	-	Med-Low (C)	Med-Low (C)	Low (D)	Low (D)
6HK(1,2)6502006 6HK16502025	19.2kW	-	-	-	Med-High (B)	Med-High (B)	Low (D)	Low (D)
6HK(1,2)6502506 6HK16502525	24kW	-	-	-	-	-	-	Low (D)

1. The referenced letter in this table is for the heat jumper tap.

2. (0,1) - 0 = no circuit breaker OR 1 = with circuit breaker.

3. (1,2) - 1 = with circuit breaker, no breaker jumper bar OR 2 = with circuit breaker & breaker jumper bar.

ELECTRIC HEAT PERFORMANCE DATA: 208/230-1-60 & 208/230-3-60

Heater Models ^{1,2}		Nominal kW @240V	Total Heat ³				kW Staging			
			kW		MBH		W1 Only		W1 + W2	
			208V	230V	208V	230V	208V	230V	208V	230V
1PH	6HK(0,1)6500206	2.4	1.8	2.2	6.2	7.5	1.8	2.2	1.8	2.2
	6HK(0,1)6500506	4.8	3.6	4.4	12.3	15.0	3.6	4.4	3.6	4.4
	6HK(0,1)6500806	7.7	5.8	7.1	19.7	24.1	5.8	7.1	5.8	7.1
	6HK(0,1)6501006	9.6	7.2	8.8	24.6	30.1	7.2	8.8	7.2	8.8
	6HK(1,2)6501306	12.5	9.4	11.5	32.0	39.2	3.1	3.8	9.4	11.5
	6HK(1,2)6501506	14.4	10.8	13.2	36.9	45.1	3.6	4.4	10.8	13.2
	6HK(1,2)6501806	17.3	13.0	15.9	44.3	54.2	6.5	7.9	13.0	15.9
	6HK(1,2)6502006	19.2	14.4	17.6	49.2	60.2	7.2	8.8	14.4	17.6
	6HK(1,2)6502506	24.0	18.0	22.0	61.5	75.2	7.2	8.8	18.0	22.0
3PH	6HK06501025	9.6	7.2	8.8	24.6	30.1	7.2	8.8	7.2	8.8
	6HK06501525	14.4	10.8	13.2	36.9	45.1	10.8	13.2	10.8	13.2
	6HK06501825	17.3	13.0	15.9	44.3	54.2	13.0	15.9	13.0	15.9
	6HK16502025	19.2	14.4	17.6	49.2	60.2	7.2	8.8	14.4	17.6
	6HK16502525	24.0	18.0	22.0	61.5	75.2	9.0	11.0	18.0	22.0

1. (0,1) - 0 = no circuit breaker OR 1 = with circuit breaker.

2. (1,2) - 1 = with circuit breaker, no breaker jumper bar OR 2 = with circuit breaker & breaker jumper bar.

3. For different power distributions, see conversion table on Page 5.

ELECTRICAL DATA FOR SINGLE SOURCE POWER SUPPLY - 208/230-1-60

Air Handler Models	Heater Models ^{1,2}	Heater Amps @240V	Field Wiring					
			Min. Circuit Ampacity		MOP. ³		Min Wire Size (AWG) ⁴	
			208V	230V	208V	230V	208V	230V
AHV18B	6HK(0,1)6500206	10.0	14.2	15.4	15	20	12	12
	6HK(0,1)6500506	20.0	25.0	27.9	30	30	10	10
	6HK(0,1)6500806	32.0	38.0	42.9	40	45	8	8
	6HK(0,1)6501006	40.0	46.7	52.9	50	60	8	6
AHV24B AHV30B	6HK(0,1)6500206	10.0	14.2	15.4	15	20	12	12
	6HK(0,1)6500506	20.0	25.0	27.9	30	30	10	10
	6HK(0,1)6500806	32.0	38.0	42.9	40	45	8	8
	6HK(0,1)6501006	40.0	46.7	52.9	50	60	8	6
	6HK(1,2)6501306	52.0	59.7	67.9	60	70	6	4
	6HK(1,2)6501506	60.0	68.4	77.9	70	80	4	4
AHV36C AHV42D	6HK(0,1)6500206	10.0	15.3	16.5	20	20	12	12
	6HK(0,1)6500506	20.0	26.2	29.0	30	30	10	10
	6HK(0,1)6500806	32.0	39.2	44.0	40	45	8	8
	6HK(0,1)6501006	40.0	47.8	54.0	50	60	8	6
	6HK(1,2)6501306	52.0	60.8	69.0	70	70	6	4
	6HK(1,2)6501506	60.0	69.5	79.0	70	80	4	4
	6HK(1,2)6501806	72.0	82.5	94.0	90	100	3	3
	6HK(1,2)6502006	80.0	91.2	104.0	100	110	3	3
AHV48D	6HK(0,1)6500206	10.0	17.5	18.6	20	20	12	12
	6HK(0,1)6500506	20.0	28.3	31.1	30	35	10	8
	6HK(0,1)6500806	32.0	41.3	46.1	45	50	8	8
	6HK(0,1)6501006	40.0	50.0	56.1	50	60	8	6
	6HK(1,2)6501306	52.0	63.0	71.1	70	80	6	4
	6HK(1,2)6501506	60.0	71.6	81.1	80	90	4	4
	6HK(1,2)6501806	72.0	84.6	96.1	90	100	4	3
	6HK(1,2)6502006	80.0	93.3	106.1	100	110	3	2
AHV60D	6HK(0,1)6500206	10.0	17.5	18.6	20	20	12	12
	6HK(0,1)6500506	20.0	28.3	31.1	30	35	10	8
	6HK(0,1)6500806	32.0	41.3	46.1	45	50	8	8
	6HK(0,1)6501006	40.0	50.0	56.1	50	60	8	6
	6HK(1,2)6501306	52.0	63.0	71.1	70	80	6	4
	6HK(1,2)6501506	60.0	71.6	81.1	80	90	4	4
	6HK(1,2)6501806	72.0	84.6	96.1	90	100	4	3
	6HK(1,2)6502006	80.0	93.3	106.1	100	110	3	2
	6HK(1,2)6502506	100.0	115.0	131.1	125	150	2	1/0

1. (0,1) - 0 = no circuit breaker OR 1 = with circuit breaker.

2. (1,2) - 1 = with circuit breaker, no breaker jumper bar OR 2 = with circuit breaker & breaker jumper bar.

3. MOP = Maximum Overcurrent Protection device; must be HACR type circuit breaker or time delay fuse.

4. Stated sizes are for 75°C, copper wire only. If wire other than non-plated, 75°C ambient, copper wire is used, consult applicable tables of the NEC and local codes.

ELECTRICAL DATA FOR MULTI-SOURCE POWER SUPPLY: 208/230-1-60

Air Handler Models	Heater Models	Total Heater Amps @240 V	Min. Circuit Ampacity						MOP ¹						Min. Wire Size (AWG) ²					
			208V			230V			208V			230V			208V			230V		
			Circuit						Circuit						Circuit					
			1st ³	2nd	3rd	1st ³	2nd	3rd	1st ³	2nd	3rd	1st ³	2nd	3rd	1st ³	2nd	3rd	1st ³	2nd	3rd
AHV24B	6HK16501306	52.0	22.2	37.6	–	24.6	43.3	–	25	40	–	25	45	–	10	8	–	10	8	–
AHV30B	6HK16501506	60.0	25.1	43.3	–	27.9	50.0	–	30	45	–	30	50	–	10	8	–	10	8	–
AHV36C AHV42D	6HK16501306	52.0	23.3	37.6	–	25.7	43.3	–	25	40	–	30	45	–	10	8	–	10	8	–
	6HK16501506	60.0	26.2	43.3	–	29.0	50.0	–	30	45	–	30	50	–	10	8	–	10	8	–
	6HK16501806	72.0	43.5	39.0	–	49.0	45.0	–	45	40	–	50	45	–	8	8	–	8	8	–
	6HK16502006	80.0	47.8	43.3	–	54.0	50.0	–	50	45	–	60	50	–	8	8	–	6	8	–
AHV48D	6HK16501306	52.0	25.4	37.6	–	27.8	43.3	–	30	40	–	30	45	–	10	8	–	10	8	–
	6HK16501506	60.0	28.3	43.3	–	31.1	50.0	–	30	45	–	35	50	–	10	8	–	8	8	–
	6HK16501806	72.0	45.6	39.0	–	51.1	45.0	–	50	40	–	60	45	–	8	8	–	6	8	–
	6HK16502006	80.0	49.9	43.3	–	56.1	50.0	–	50	45	–	60	50	–	8	8	–	6	8	–
AHV60D	6HK16501306	52.0	25.4	37.6	–	27.8	43.3	–	30	40	–	30	45	–	10	8	–	10	8	–
	6HK16501506	60.0	28.3	43.3	–	31.1	50.0	–	30	45	–	35	50	–	10	8	–	8	8	–
	6HK16501806	72.0	45.6	39.0	–	51.1	45.0	–	50	40	–	60	45	–	8	8	–	6	8	–
	6HK16502006	80.0	49.9	43.3	–	56.1	50.0	–	50	45	–	60	50	–	8	8	–	6	8	–
	6HK16502506	100.0	49.9	43.3	21.7	56.1	50.0	25.0	50	45	25	60	50	25	8	8	10	6	8	10

1. MOP = Maximum Overcurrent Protection device; must be HACR type circuit breaker or time delay fuse.

2. Stated sizes are for 75°C, copper wire only. If wire other than non-plated, 75°C ambient, copper wire is used, consult applicable tables of the NEC and local codes.

3. 1st Circuit includes the blower motor amps.

ELECTRICAL DATA FOR SINGLE SOURCE POWER SUPPLY - 208/230-3-60

Air Handler Models	Heater Models	Heater Amps @ 240V	Field Wiring					
			Min. Circuit Ampacity		MOP ¹		Min. Wire Size (AWG) ²	
			208V	230V	208V	230V	208V	230V
AHV24B AHV30B	6HK06501025	23.1	28.4	31.8	30	35	10	8
	6HK06501525	34.6	40.9	46.1	45	50	8	8
AHV36C AHV42D	6HK06501025	23.1	29.5	32.9	30	35	10	8
	6HK06501525	34.6	42.0	47.3	45	50	8	8
	6HK06501825	41.6	49.6	56.0	50	60	8	6
	6HK16502025 ³	46.2	54.6	61.8	60	70	6	6
AHV48D	6HK06501025	23.1	31.7	35.0	35	35	8	8
	6HK06501525	34.6	44.1	49.4	45	50	8	8
	6HK06501825	41.6	51.7	58.1	60	60	6	6
	6HK16502025 ³	46.2	56.7	63.9	60	70	6	6
AHV60D	6HK06501025	23.1	31.7	35.0	35	35	8	8
	6HK06501525	34.6	44.1	49.4	45	50	8	8
	6HK06501825	41.6	51.7	58.1	60	60	6	6
	6HK16502025 ³	46.2	56.7	63.9	60	70	6	6
	6HK16502525 ³	57.7	69.1	78.3	70	80	4	4

1. MOP = Maximum Overcurrent Protection device; must be HACR type circuit breaker or time delay fuse.

2. Stated sizes are for 75°C, copper wire only. If wire other than non-plated, 75°C ambient, copper wire is used, consult applicable tables of the NEC and local codes..

3. The 20kW and 25kW heater models (6HK16502025 and 6HK16502525) come with circuit breakers standard. Single source power MCA and MOP requirements are given here only for reference if used with field installed single point power modification.

ELECTRICAL DATA FOR MULTI-SOURCE POWER SUPPLY: 208/230-3-60

Air Handler Models	Heater Models	Total Heater Amps @ 240V	Min. Circuit Ampacity				MOP ¹				Min. Wire Size (AWG) ²			
			208V		230V		208V		230V		208V		230V	
			Circuit				Circuit				Circuit			
			1st ³	2nd	1st ³	2nd	1st ³	2nd	1st ³	2nd	1st ³	2nd	1st ³	2nd
AHV36C AHV42D	6HK16502025	46.2	29.5	25.0	32.9	28.9	30	25	35	30	10	10	8	10
AHV48D	6HK16502025	46.2	31.7	25.0	35.0	28.9	35	25	35	30	8	10	8	10
AHV60D	6HK16502025	46.2	31.7	25.0	35.0	28.9	35	25	35	30	8	10	8	10
	6HK16502525	57.7	37.9	31.3	42.2	36.1	40	35	45	40	8	8	8	8

1. MOP = Maximum Overcurrent Protection device; must be HACR type circuit breaker or time delay fuse.
2. Stated sizes are for 75°C, copper wire only. If wire other than non-plated, 75°C ambient, copper wire is used, consult applicable tables of the NEC and local codes.
3. 1st Circuit includes the fan motor.

TYPICAL APPLICATIONS

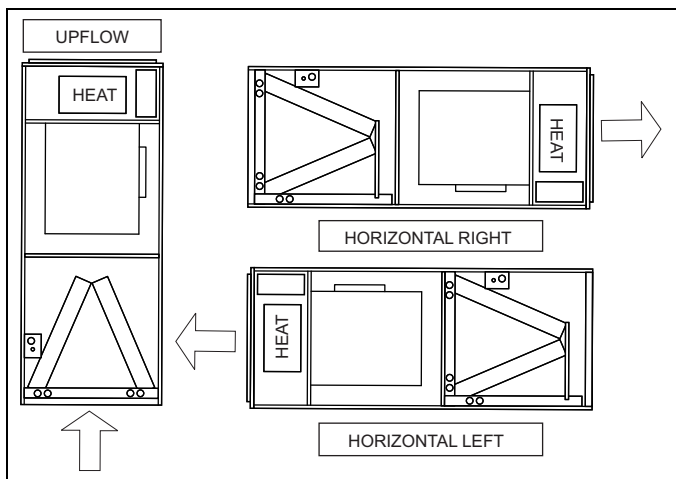

ACCESSORIES

Refer to Price Manual for specific model numbers where not shown.

TXV Kits - TXV kits are available for "Flex-coil" applications and converting R-22 to R-410A or as a service replacement. All kits are bolt-on and require no brazing to install.

Electric Heaters - 6HK models shown under electrical data include sequential operation and temperature dual limit switches for safe, efficient operation. Circuit breakers are provided where shown.

LIMITATIONS

These units must be wired and installed in accordance with all national and local safety codes.

Voltage limits are as follows:

Air Handler Voltage	¹ Normal Operating Voltage Range
208/230-1-60	187-253

1. Rated in accordance with ARI Standard 110, utilization range "A".

Airflow must be within the minimum and maximum limits approved for electric heat, evaporator coils and outdoor units.

TYPICAL THERMOSTAT CONNECTION

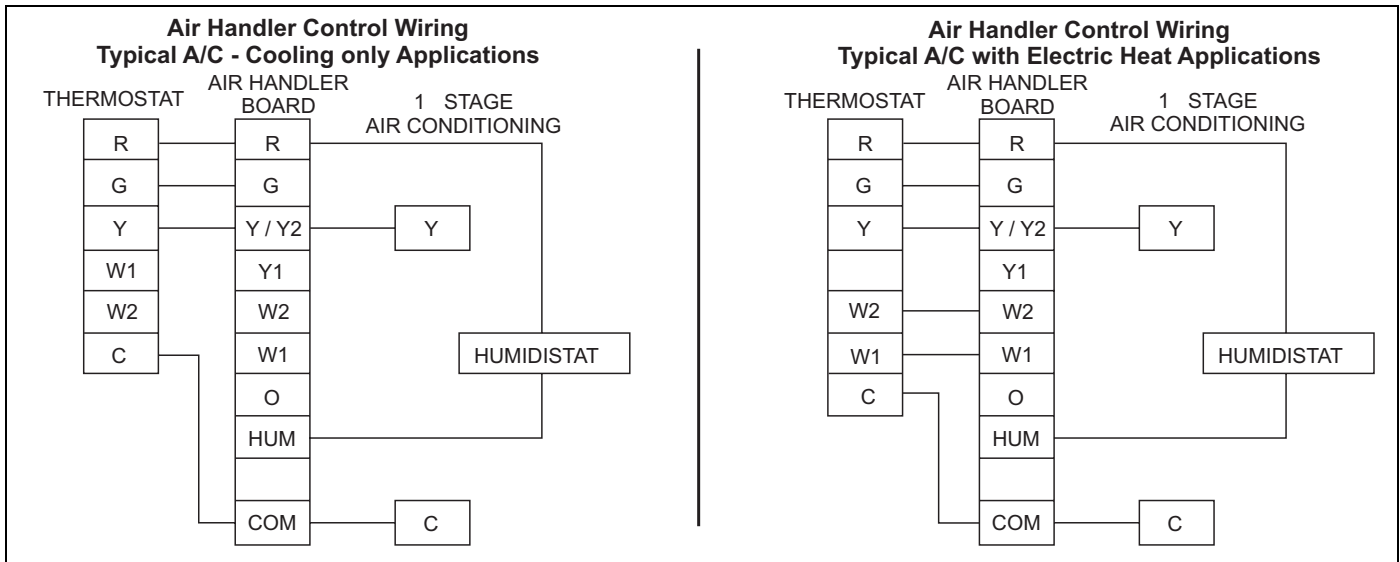

Cooling Models with and without Electric Heat Wiring

* Optional dehumidification humidistat switch contacts open on humidity rise.

NOTES:

1. "Y/Y2" Thermostat wire must be connected for full CFM and applications requiring 60 second blower off delay for SEER enhancement.
2. Remove humidistat jumper on air handler control board.
3. For heat pump applications - set AC/HP jumper on air handler control board to the HP position.

TYPICAL THERMOSTAT WIRING FOR 2-STAGE HEAT PUMP WITH ECM BLOWER MOTOR

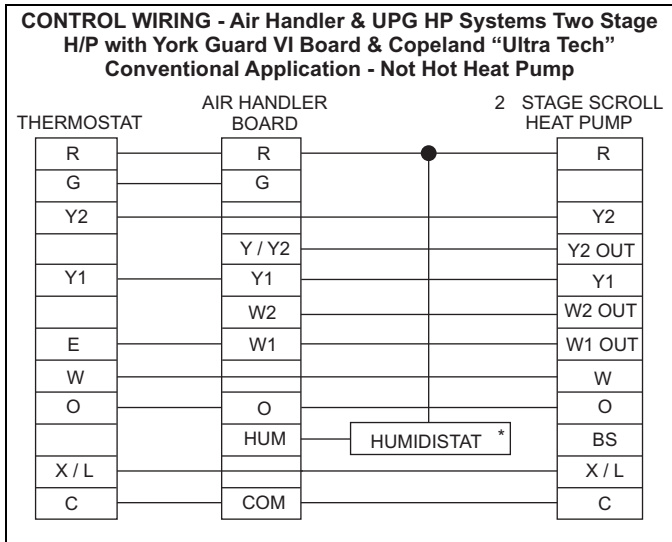

* Optional dehumidification humidistat switch contacts open on humidity rise.

NOTES:

1. "Y/Y2" Thermostat wire must be connected for full CFM and applications requiring 60 second blower off delay for SEER enhancement.
2. Remove humidistat jumper on air handler control board.
3. For heat pump applications - set AC/HP jumper on air handler control board to the HP position.

AIR HANDLER WITH COMMUNICATING AC OR HP

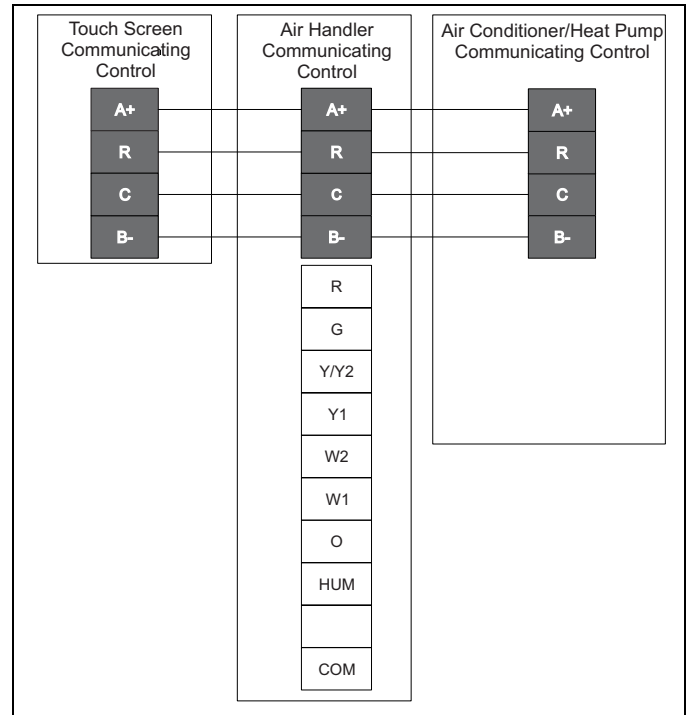

FIGURE 1: Air Handler with Communicating AC or HP

AIR FLOW DATA (CFM)¹

High/Low Speed Cooling and Heat Pump CFM									
Cool Tap	ADJ Tap ²	AHV18		AHV24		AHV30		AHV36	
		High	Low	High	Low	High	Low	High	Low
A	B	805	523	1035	673	1150	748	1380	897
B	B	690	449	920	598	1035	673	1208	794
A	A	700	455	900	585	1000	650	1200	780
B	A	600	390	800	520	900	585	1050	690
A	C	630	410	810	527	900	585	1080	702
C	B	575	374	776	506	920	598	1035	673
B	C	540	351	720	468	810	527	945	621
D	B	460	299	633	414	805	523	863	564
C	A	500	325	675	440	800	520	900	585
D	A	400	260	550	360	700	455	750	490
C	C	450	293	608	396	720	468	810	527
D	C	360	234	495	324	630	410	675	441

Cool Tap	ADJ Tap ²	AHV42		AHV48		AHV60	
		High	Low	High	Low	High	Low
A	B	1610	1047	1840	1196	2070	1346
B	B	1495	972	1668	1093	1811	1179
A	A	1400	910	1600	1040	1800	1170
B	A	1300	845	1450	950	1575	1025
A	C	1260	819	1440	936	1620	1053
C	B	1380	897	1495	972	1668	1081
B	C	1170	761	1305	855	1418	923
D	B	1265	822	1323	863	1570	1024
C	A	1200	780	1300	845	1450	940
D	A	1100	715	1150	750	1365	890
C	C	1080	702	1170	761	1305	846
D	C	990	644	1035	675	1229	801

High/Low Speed Heat CFM									
Heat Tap	ADJ Tap ²	AHV18		AHV24		AHV30		AHV36	
		High	Low	High	Low	High	Low	High	Low
A	Any	850	650	1100	740	1100	740	1360	900
B	Any	700	600	960	650	960	650	1150	770
C	Any	550	550	830	600	830	600	1000	630
D	Any	400	400	580	550	580	550	720	550

Heat Tap	ADJ Tap ²	AHV42		AHV48		AHV60	
		High	Low	High	Low	High	Low
A	Any	1550	950	1775	1000	2000	1150
B	Any	1350	800	1600	850	1840	1050
C	Any	1150	670	1360	750	1570	950
D	Any	900	550	1170	600	1370	830

1. All CFMs are shown at 0.3" w.c. external static pressure. These units have variable-speed ECM motors that automatically adjust to provide constant CFM from 0.0" to 0.4" w.c. external static pressure. From 0.4" to 0.8" external static pressure, CFM is reduced by 2% per 0.1" static pressure. Operation of these units on duct systems with external static pressure greater than 0.8" is not recommended.

At some settings, airflow may be lower than what is required to operate an airflow switch on certain models of electronic air cleaners. Consult the instructions for the electronic air cleaner for further details.

Data is for 208V or 230V.

2. The ADJ "D" tap should not be used.

WIRING DIAGRAMS

WHEN INSTALLING HEATER KIT, BE SURE THE BLOWER SPEED IS SET TO THE SPEED SPECIFIED FOR THE AIR HANDLER/HEATER KIT COMBINATION ON THIS UNIT'S INSTALLATION INSTRUCTIONS.

SEE INSTALLATION INSTRUCTIONS FOR PROPER LOW VOLTAGE FIELD WIRING CONNECTIONS.

HEATER KITS:
6HK#6500206
6HK#6500506

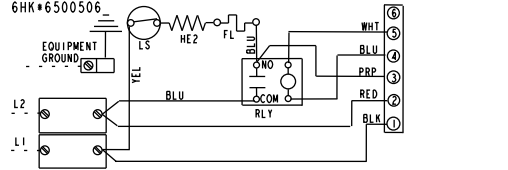

HEATER KITS:
6HK#6500806
6HK#6501006

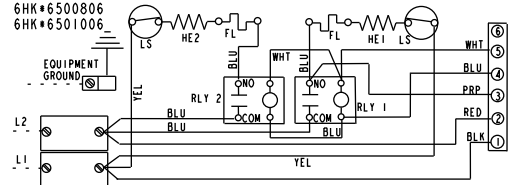

HEATER KITS:
6HK16501306
6HK16501506

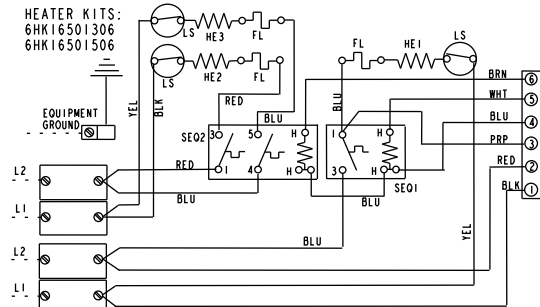

HEATER KITS:
6HK16501806
6HK16502006

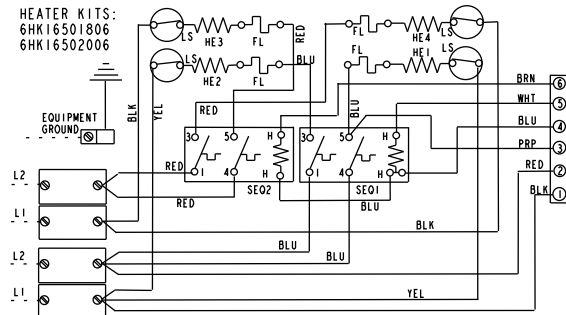

HEATER KIT:
6HK16502506

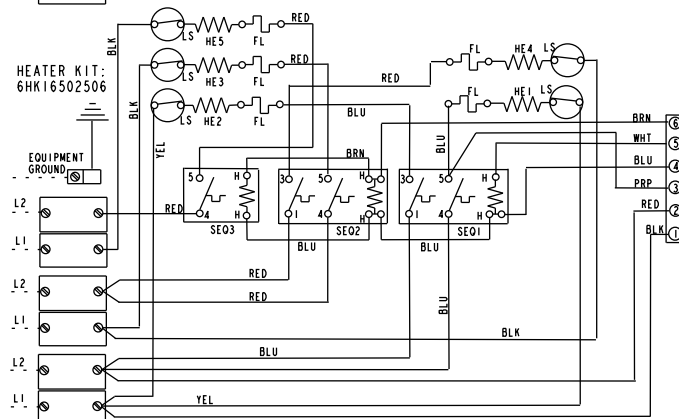

208-240 VAC 60HZ
1 PHASE SUPPLY

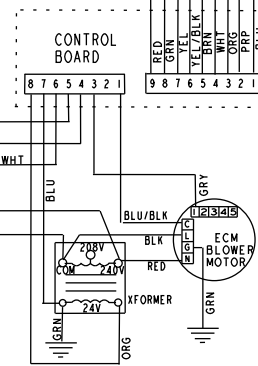

ECM AIR HANDLER WITH
NO HEAT KIT WIRING DIAGRAM

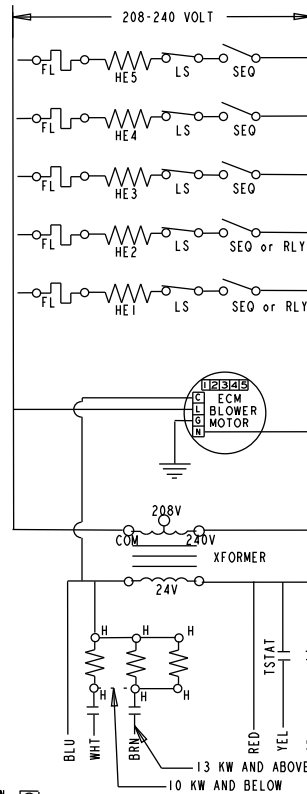

LEGEND
LS - LIMIT SWITCH
SEQ - SEQUENCER
HE - HEATING ELEMENT
FL - FUSIBLE LINK
H - SEQUENCER HEATER
RLY - RELAY
TSTAT - WALL THERMOSTAT

USE COPPER CONDUCTORS ONLY.
IF ALUMINUM CONDUCTORS ARE PRESENT,
ALL APPLICABLE LOCAL AND NATIONAL
CODES MUST BE FOLLOWED.

818695-UWD-A-1111

WIRING DIAGRAM - SINGLE PHASE HEAT KITS

HEATER KITS:
6HK06501025
6HK06501525

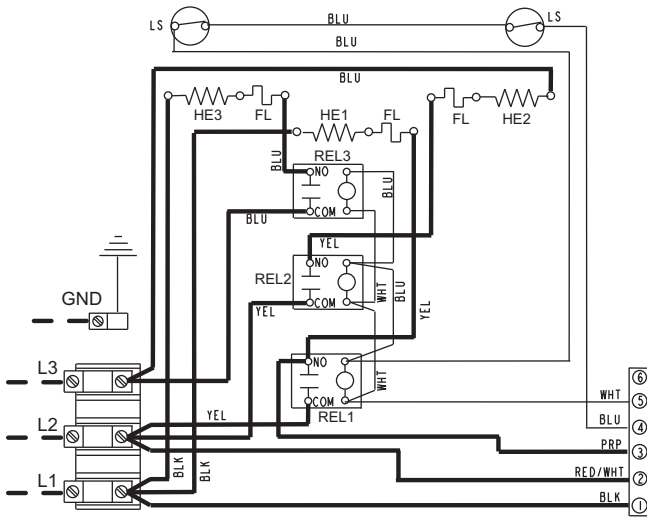

HEATER KITS:
6HK06501825

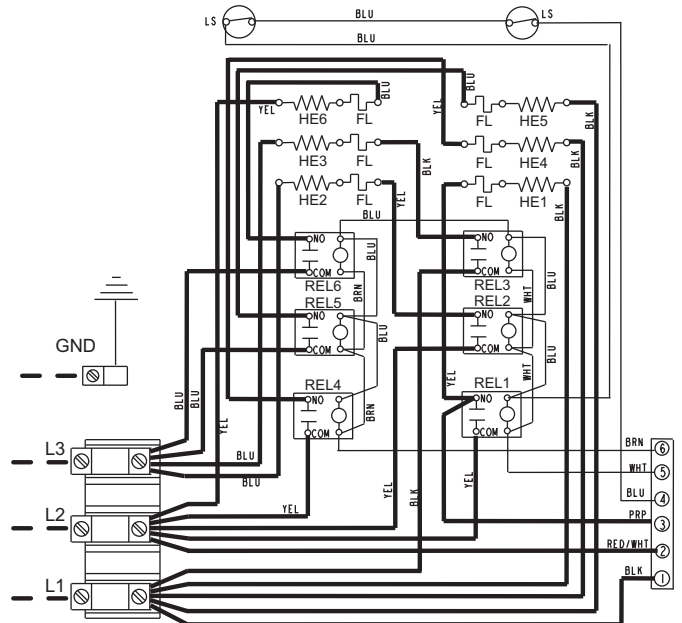

HEATER KITS:
6HK16502025
6HK16502525

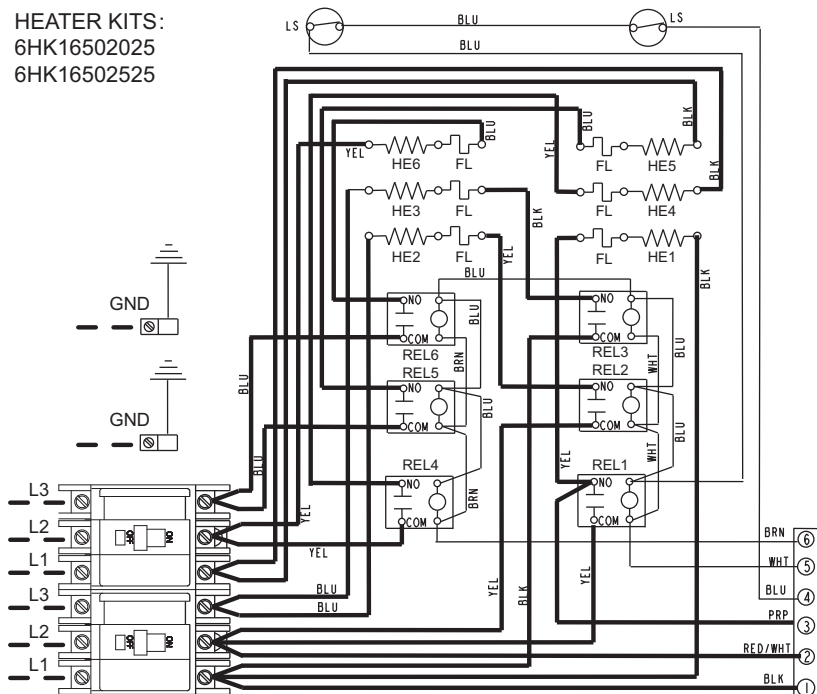

COMPONENT CODES

- GND EQUIPMENT GROUND
- FL FUSIBLE LINK
- HE HEATING ELEMENT
- LS LIMIT SWITCH
- REL RELAY

- FIELD POWER WIRING (208/230V)
- FACTORY WIRING (208/230V)
- FACTORY WIRING LOW VOLTAGE

WIRING DIAGRAM - 3 PHASE HEAT KITS

NOTES