



## TECHNICAL GUIDE

### MILLENNIUM®

### SINGLE PACKAGE ROOFTOP UNITS

#### Z2, Z3 & Z4 (R-410A)

#### 25, 30, & 40 TON

25, 30 & 40 Ton (Efficiencies up to 10.7 EER & 13.8 IEER)



40 TON UNIT SHOWN



## TOMORROW'S UNIT TODAY

### GENERAL

Introducing the YORK Millennium 25, 30, & 40 ton rooftop line - units designed to provide peak performance and value both today and for years to come. Millennium units are manufactured at an ISO 9001 registered facility, and each rooftop is completely computer-run tested prior to shipment.

The Millennium is designed to be flexible enough to meet your needs today and in the future. The true value of YORK's Millennium is that it can be designed to fit any need, from cooling only, stepped or modulating gas heat, constant volume discrete fan control (multi-speed) applications to variable air volume systems with variable frequency drive.

### FEATURING:

- Cooling Only Units
- Cooling/Gas Heating Units (Natural) Standard or Modulating Gas Heat available
- Cooling/Electric Heating Units
- Cooling/Hot Water Heating Units
- Cooling/Steam Heating Units
- ASHRAE 90.1 and IECC complaint
- Industry Leading Efficiency
- Double Wall Construction
- Stainless Steel or Powder Coated Drain Pan
- Multiple Scroll Compressors
- Multiple Refrigeration Circuits
- Enhanced Filtration
- Vibration Isolated Supply Fan and Motor
- TechniCoated Evaporator and Condenser Coils
- Single Power Point Connection
- Easy Access Hinged Doors
- Variable Air Volume
- Constant Air Volume
- IntelliSpeed™-Discrete Fan Control (Multi-Speed)
- Factory Installed Economizers/Disconnect/Convenience Outlet/Control Options

### MILLENNIUM SMART EQUIPMENT™ FEATURES:

- Built-in LCD display and easy to use navigation joystick and buttons allowing the user to quickly navigate the menus displaying unit status, options, current function, supply, return and outdoor temperatures, fault codes and other information.
- Designed to operate on both constant and variable air volume units
- 365-Day real time clock
- Occupancy Schedule allowing two schedules per day
- 20 Holiday schedules with programmable schedules that can start at any time, day or night
- Patented Comfort Ventilation operation for economical and comfortable economizer operation
- Demand Ventilation option to assure proper IAQ conditions based on available space or return air CO<sub>2</sub> levels
- Temperature/Humidity programming algorithm allows programmable limits to help control humidity in the space
- Smoke Purge automatically ventilates the space when smoke is detected
- Monitors dirty filters and proves airflow before starting heating or cooling
- Intelligent recovery to bring the space temperature up to occupied setting quicker and more economically

## TABLE OF CONTENTS

<b>GENERAL</b> .....	<b>AIR INLET SYSTEM</b> .....
FEATURING: .....	GENERAL .....
MILLENNIUM SMART EQUIPMENT™ FEATURES: .....	ECONOMIZER (OPTIONAL) .....
<b>OVERVIEW</b> .....	RELIEF SYSTEM (OPTIONAL) .....
<b>FEATURES AND BENEFITS</b> .....	BAROMETRIC RELIEF (OPTIONAL) .....
INSTALLATION FEATURES .....	EXHAUST AIR FANS (OPTIONAL) .....
CONSTRUCTION FEATURES .....	ENERGY RECOVERY VENTILATION (FIELD INSTALLED OPTION) .....
LIST OF FEATURES AND BENEFITS .....	GENERAL .....
STANDARD FEATURES .....	<b>HEATING SYSTEM</b> .....
FACTORY INSTALLED OPTIONS .....	GAS-FIRED HEATING SECTION (OPTIONAL) .....
FIELD INSTALLED ACCESSORIES .....	ELECTRIC HEATING SECTION .....
<b>NOMENCLATURE</b> .....	HOT WATER HEATING COIL .....
<b>SELECTION PROCEDURE</b> .....	STEAM HEATING COIL .....
SELECT UNIT: .....	<b>REFRIGERATION SYSTEM</b> .....
SELECT FAN SPEED AND HORSEPOWER .....	EVAPORATOR COILS .....
REQUIREMENTS OF SUPPLY AIR FAN .....	COMPRESSORS .....
SIZE OVERCURRENT PROTECTION DEVICE AND DETERMINE CIRCUIT AMPACITY .....	CONDENSER COILS .....
<b>HOT WATER HEATING</b> .....	CONDENSER FANS AND MOTORS .....
PHYSICAL DATA HOT WATER COIL - 1 ROW .....	REFRIGERANT PIPING .....
PIPING CONNECTIONS .....	HOT GAS BYPASS (OPTIONAL ON CV; STANDARD ON VAV) .....
PHYSICAL DATA HOT WATER COIL - 2 ROW .....	<b>CONTROLS</b> .....
<b>STEAM HEATING</b> .....	GENERAL DESCRIPTION .....
PHYSICAL DATA STEAM COIL - 1 ROW .....	COMPRESSOR CONTROL .....
PIPING CONNECTIONS .....	FAN CONTROL .....
<b>SUPPLY AIR DRIVE ADJUSTMENT</b> .....	EQUIPMENT CONTROL FEATURES .....
CFM, STATIC PRESSURE, AND POWER - ALTITUDE AND TEMPERATURE CORRECTIONS .....	<b>COMFORT CONTROL FEATURES</b> .....
<b>ELECTRICAL DATA</b> .....	OPTIONAL CONTROL .....
<b>GUIDE SPECIFICATIONS - YORK</b> .....	VERASYS .....
<b>MILLENNIUM 25, 30, &amp; 40 TON UNITS</b> .....	FDD (FAULT DETECTION AND DIAGNOSTICS) - REFRIG- ERANT SIDE .....
GENERAL .....	<b>AVAILABLE ACCESSORIES</b> .....
DESCRIPTION .....	PARTIAL PERIMETER ROOF CURBS .....
CONSTRUCTION .....	BURGLAR BARS .....
BASE .....	FIELD INSTALLED BAROMETRIC RELIEF .....
CASING .....	PROGRAMMABLE THERMOSTAT, WITH OR WITHOUT REMOTE SENSOR (REQUIRED FOR CONSTANT VOL- UME UNITS) .....
SUPPLY AIR SYSTEM .....	REMOTE WALL MOUNTED TEMPERATURE SENSORS ..
SUPPLY AIR FAN .....	PROPANE CONVERSION KITS .....
OPTIONAL .....	HIGH ALTITUDE CONVERSION KITS .....
BEARINGS AND DRIVES .....	ENERGY RECOVERY VENTILATORS .....
AIR FILTERING SYSTEM .....	
OPTIONAL .....	

## LIST OF FIGURES

<u>Fig.#</u>	<u>Pg.#</u>	<u>Fig.#</u>	<u>Pg.#</u>
1	HOT WATER PIPING CROSS-SECTION . . . . .	15	
2	HOT WATER COIL - 25 & 30 TON, 1 ROW, AT 10 GPM	16	
3	HOT WATER COIL - 25 & 30 TON, 1 ROW, AT 20 GPM	16	
4	HOT WATER COIL - 25 & 30 TON, 1 ROW, AT 30 GPM	17	
5	HOT WATER COIL - 25 & 30 TON, 1 ROW, AT 40 GPM	17	
6	HOT WATER COIL - 40 TON, 1 ROW, AT 10 GPM .	18	
7	HOT WATER COIL - 40 TON, 1 ROW, AT 20 GPM .	18	
8	HOT WATER COIL - 40 TON, 1 ROW, AT 30 GPM .	19	
9	HOT WATER COIL - 40 TON, 1 ROW, AT 40 GPM .	19	
10	HOT WATER COIL - 25 & 30 TON, 2 ROW, AT 20 GPM	21	
11	HOT WATER COIL - 25 & 30 TON, 2 ROW, AT 40 GPM	21	
12	HOT WATER COIL - 25 & 30 TON, 2 ROW, AT 60 GPM	22	
13	HOT WATER COIL - 25 & 30 TON, 2 ROW, AT 80 GPM	22	
14	HOT WATER COIL - 40 TON, 2 ROW, AT 20 GPM .	23	
15	HOT WATER COIL - 40 TON, 2 ROW, AT 40 GPM .	23	
16	HOT WATER COIL - 40 TON, 2 ROW, AT 60 GPM .	24	
17	HOT WATER COIL - 40 TON, 2 ROW, AT 80 GPM .	24	
18	STEAM PIPING CROSS SECTION . . . . .	25	
19	STEAM COIL - 25 & 30 TON, 1 ROW . . . . .	26	
20	STEAM COIL - 40 TON, 1 ROW . . . . .	26	
21	ALTITUDE/TEMPERATURE CONVERSION FACTOR .	38	
22	40 TON FORWARD CURVE EXAMPLE . . . . .	39	
23	FAN PERFORMANCE - 25 TON . . . . .	41	
24	FAN PERFORMANCE - 30 TON . . . . .	43	
25	FAN PERFORMANCE - 40 TON . . . . .	45	
26	POWER EXHAUST - ONE FORWARD CURVE FAN - 25 TONS . . . . .	48	
27	POWER EXHAUST - TWO FORWARD CURVED FANS - 30 & 40 TONS . . . . .	50	
28	CENTER OF GRAVITY . . . . .	76	
29	COMPONENT LOCATION . . . . .	78	
30	END RETURN, BOTTOM SUPPLY . . . . .	79	
31	BOTTOM SUPPLY AND RETURN . . . . .	80	
32	BOTTOM RETURN, FRONT & REAR SUPPLY . . . .	81	
33	END RETURN, FRONT & REAR SUPPLY . . . . .	82	
34	25 TON MILLENNIUM OVERHEAD VIEW . . . . .	83	
35	30 AND 40 TON MILLENNIUM OVERHEAD VIEW .	83	
36	25 TON MILLENNIUM MAJOR COMPONENT LAYOUT	84	
37	30 AND 40 TON MILLENNIUM MAJOR COMPONENT LAYOUT . . . . .	84	
38	MILLENNIUM CABINET DOOR CONFIGURATION .	85	
39	CLEARANCES - HOOD/ECONOMIZER & MOTOR DRIVE - SIDE . . . . .	86	
40	CLEARANCES - HOOD/ECONOMIZER & MOTOR DRIVE - FRONT & END . . . . .	86	
41	PARTIAL ROOF CURB MODEL 1RC0455P . . . . .	87	

## LIST OF TABLES

<u>Table#</u>	<u>Pg.#</u>	<u>Table#</u>	<u>Pg.#</u>
1	10	33	31
2	11	34	32
3	12	35	33
4	12	36	35
5	12	37	37
6	12	38	40
7	13	39	42
8	3	40	44
9	14	41	46
10	14	42	47
11	14	43	49
12	15	44	51
13	15	45	53
14	20	46	54
15	20	47	55
16	20	48	56
17	20	49	57
18	20	50	58
19	20	51	60
20	25	52	61
21	25	53	63
22	25	54	64
23	25	55	66
24	28	56	67
25	28	57	69
26	29	58	70
27	29	59	72
28	29	60	73
29	30	61	75
30	30	62	76
31	30	63	76
32	30	64	76
		65	76
		66	77
		67	77
		68	77
		69	78

## YORK Millennium®

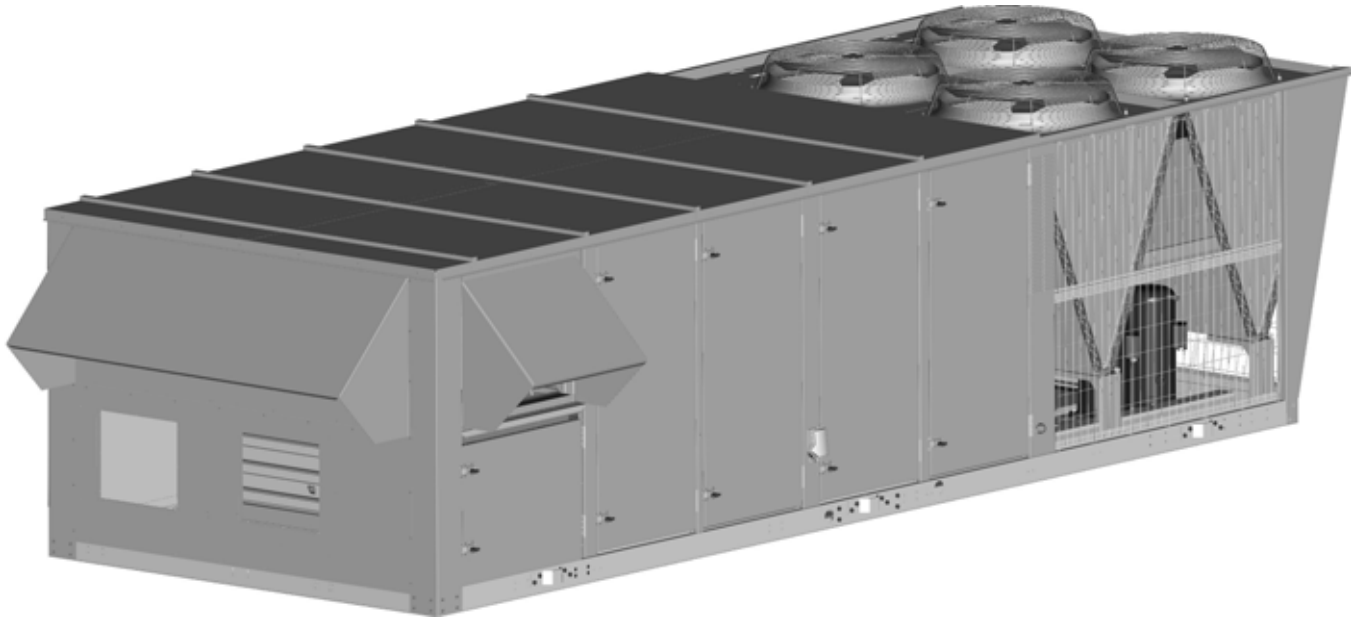

### OVERVIEW

Introducing the YORK Millennium 25, 30, & 40 ton rooftop line - units designed to provide peak performance and value both today and for years to come. When we asked our customers what they wanted in a new rooftop line, we were careful to listen to both the needs of today and tomorrow. So, you'll find that Millennium units not only help you solve today's problems, but can handle tomorrow's difficulties as well:

Industry Leading Efficiency - The Millennium with EER ratings of up to 10.7 and IEER ratings up to 13.8 make it the most frugal energy consumer in its class. When it comes to lower operating costs, Millennium simply outperforms the competition.

Double Wall Construction - Millennium units come double walled as standard. The galvanized sheet metal liner provides the best protection against microbial growth, helping both the unit and the indoor air stay fresh and clean. And, the rigid sheet metal inner liner keeps the insulation completely out of the air stream, eliminating concerns about fiberglass particles.

Drain Pan Whisks Away Condensate - Condensate is frequently the source of microbial contamination. Competitive drain pans often are insufficiently sloped to properly drain all of the condensate, causing drain pan corrosion and bacterial growth to begin almost immediately. The YORK design is sloped at the 1/4" per foot recommended by the ASHRAE 62.1-2004 ventilation draft standard, with an extra large drain connection capable of removing up to three gallons of condensate per minute. It is available in either powder coat painted steel or stainless steel for long life.

Efficient, Durable Scroll Compressors - The Millennium design uses industrial grade hermetic scroll compressors for peak efficiency and low noise operation. The compressor design is so durable that it can actually hold more liquid charge without slugging than is present in each refrigerant circuit at shipment, dramatically reducing the chances of ever slugging a compressor with liquid charge.

Multiple Refrigeration Circuits for Greater Turndown - The YORK Millennium unit has intertwined circuits giving the best unloading capability in the industry. With more and more designs requiring higher outside air quantities, the lower capacity capability is an outstanding way to neutralize outside air without over-conditioning the space on off-peak days. And, Millennium's high quality balance-port thermal expansion valves are more effective at metering refrigerant flow in part-load conditions, making Millennium a peak-performer across a wide capacity range.

### FEATURES AND BENEFITS

When it comes to flexibility, Millennium really shines. Our customers were clear about one thing - not all installations are the same. Some have very simple needs, others are more involved. The YORK Millennium serves both markets - and all of those in between - extremely well. YORK engineers crafted a design which is both uniquely flexible and competitive, giving you the best of both worlds. In addition to a competitive base product, Millennium offers unparalleled flexibility. Optional features include:

IntelliSpeed™- Discrete Fan Control - The IntelliSpeed option includes a variable frequency drive for multi-speed fan operation. This option allows the supply fan RPM to vary based on the number of compressors or heating stages activated.

Variable Air Volume - YORK gives you the ability to vary air volume by inlet guide vanes or variable frequency drive - the choice is yours. All Millennium VAV units come standard with hot gas bypass to give extended operation range.

Optional Head Pressure Control - For those applications where mechanical cooling is required below 40°F, optional low ambient operation allows compressor operation down to 0°F.

Enhanced Filtration Options - Millennium gives designers the flexibility to meet various IAQ requirements with a full range of rigid and throwaway filters at different efficiency levels.

Vibration Isolation - The Millennium's neoprene mounts are typically sufficient for most applications but when sound and vibration transmission are a major concern, YORK offers 1" and 2" isolation springs for even greater protection from supply air fan noise and vibration.

Corrosion Resistant Coils- Many industrial and seacoast applications require enhanced protection from corrosive environments.

Optional TechniCoated Coated Condenser and Evaporator Coils - Many industrial and seacoast applications require enhanced protection from corrosive environments. The special dipped phenolic coating process provides a high level of protection for the exposed condenser coil.

Optional Copper-Copper Condenser and Evaporator Coils - For corrosion resistance.

Variety of Exhaust Air Options - YORK Millennium offers a wide variety of exhaust air options, including barometric relief, non-modulating power exhaust, and modulating power exhaust. And, because Millennium units use forward-curved blowers for power exhaust fans, they can exhaust up to 100% of the nominal supply air at much greater static pressure loads than competitive units. **Not available on end return.**

**NOTE:** In most applications, the supply fan will keep the return at negative pressure. A barometric relief will function better when ducted to building space, not the return.

Optional Factory Installed Economizers - Millennium units offer economizers with Standard or Optional low leak dampers. Comparative enthalpy, single enthalpy and dry bulb control are available.

Optional Factory Installed Disconnect- A factory installed power disconnect is offered to easily allow shut off of power to the unit. The factory installed disconnect eliminates the need for a bulky, unattractive field installed disconnect to be mounted on the side of the unit. The factory disconnect is mounted internally to the unit, just behind the electrical box access panel and can also be ordered with a powered 120 volt convenience outlet. The convenience outlet is powered off when the factory disconnect is opened.

Optional Factory Installed Powered Convenience Outlet- A factory installed powered 120 volt convenience outlet option

prevents the need for a separate 120 volt circuitry on the roof to meet local codes and provides easily accessible power for tools, lighting and other 120 volt items. The optional factory convenience outlet is only available in conjunction with a factory installed disconnect.

Heating Done Your Way - Millennium offers the choice of natural gas standard or modulating gas heat, electric resistance heat, hot water heat, steam, or no heat at all. Very simply, the choice is yours.

## INSTALLATION FEATURES

With YORK Millennium, high performance doesn't mean high complexity. YORK listened carefully to make sure that Millennium was as simple as possible, and service convenience comes standard with each unit. From a single curb size to the easy service access, you'll find that Millennium was designed to be easy from start to finish.

Full Range of Air Flows and Static Pressures - The Millennium design gives a complete offering of supply air flows and static pressure combinations to meet most every application requirement.

Single Power Point Connection - Millennium units have a single gas and electric connection, minimizing time at the job site. For further installation flexibility, power and gas connections may be brought up from the curb or through the side of the unit.

Simple Controls - Millennium's controls system is easy to understand and apply, and it doesn't lock you into proprietary devices. A choice for YORK Millennium today does not limit your choices tomorrow.

Rain Hoods Rotate Into Place - No bulky, field--installed rain hoods here. Millennium rain hoods ship rotated inside the unit. Once on the job, installer merely rotates the hood upward and puts in a few screws - an easy one-person job.

Excellent Access for Service - Service access on Millennium is a snap. Hinged and latched doors give access on both sides of the unit to all major components. All doors have positive action slide latches for even greater ease of access. All service fittings are conveniently located to minimize time and effort.

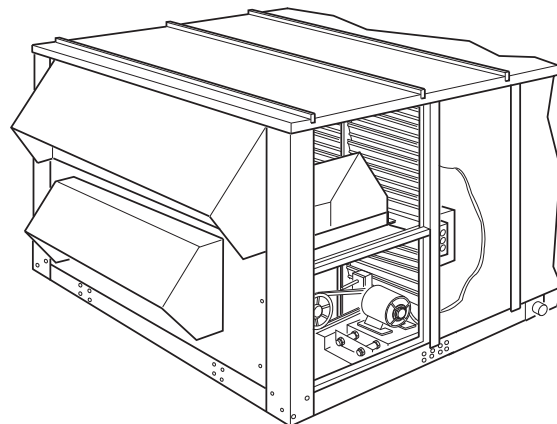

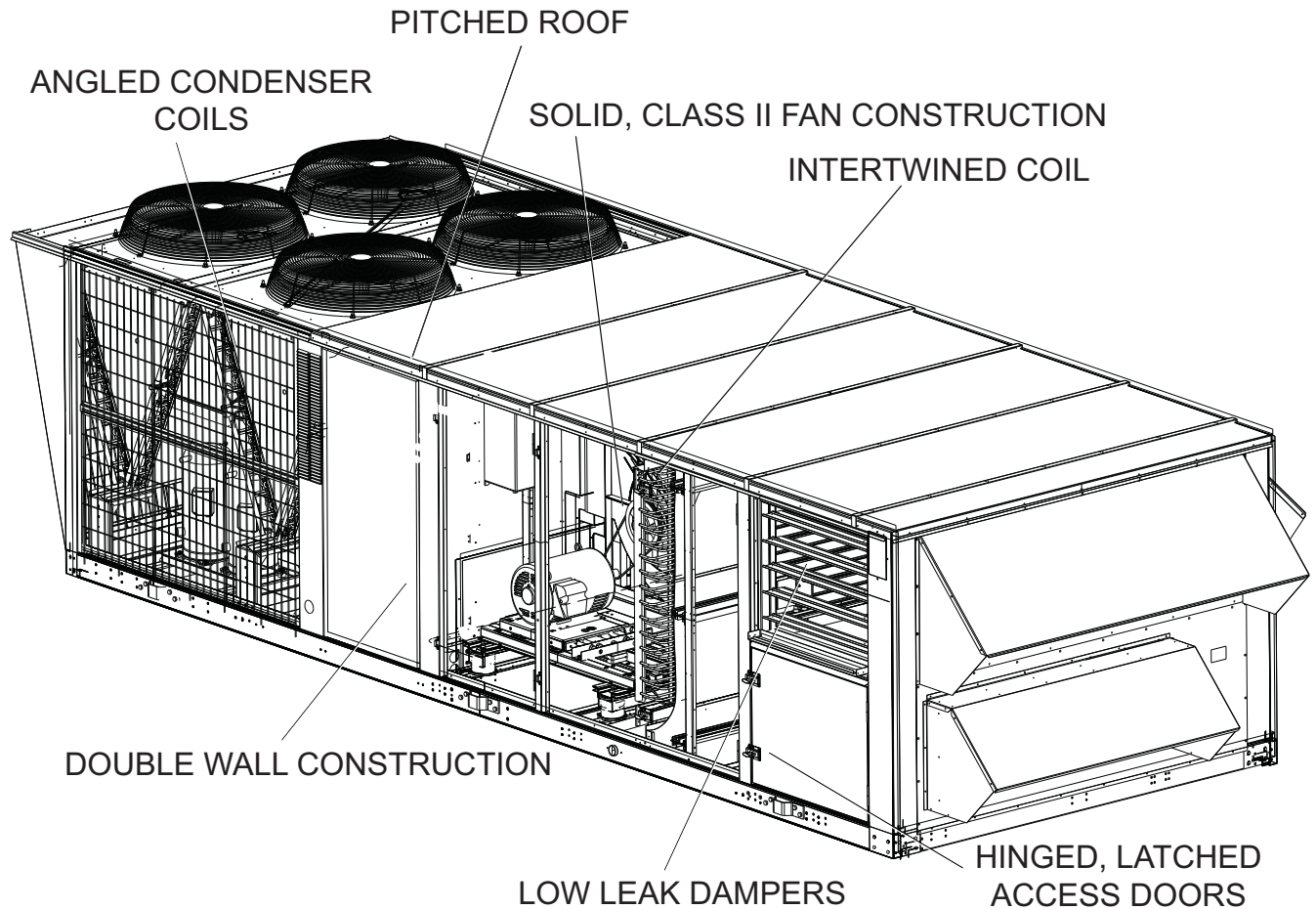

## CONSTRUCTION FEATURES

YORK's Millennium rooftop line is built for the long haul, with high end features and construction offered at a competitive price. Millennium units are manufactured at an ISO 9001 registered facility, and each rooftop is completely computer-run tested prior to shipment. Some of the valuable construction features of the Millennium which are not found on competitive units include:

**Double Wall Construction** - Each unit has both an exterior and an interior wall, which make for a more rigid design with panels and doors that are solid, not flimsy. The unit features a fully framed construction for even greater stability.

**Powder Paint** - Industry leading 750 salt spray hour paint keeps the unit in great condition for years to come.

**Low Profile** - Millennium units stand only 64" above their curb, minimizing potential aesthetic conflicts.

**Extended flue connection** - Each gas unit ships with a field mounted external flue. The flue lifts all products of furnace combustion far above the unit - eliminating the possibility of corrosion in the furnace heat exchanger from recirculating flue gases.

**Protective Covering** - Special polyurethane sleeves which cover the distributor tubing keep distributor tubes from contacting each other and wearing out.

**Built-in Hail Guard** - Condenser coils angled at 30 degrees from the vertical are inherently protected from damage due to shipment, hail, etc.

**Induced Draft Furnace** - This design provides a positive exhaust of all combustion products.

## LIST OF FEATURES AND BENEFITS

### Standard Features

- Efficiencies up to 10.7 EER and 13.8 IEER
- Double wall construction
- Major components have hinged and latched access doors
- Industrial duty scroll compressors
- Sturdy framed construction
- Sloped stainless steel or powder coated drain pan
- Four independent cooling circuits
- Intertwined evaporator coil
- Angled condenser coils for superior protection
- Single power point connection
- Through-the-curb or through-the-base utility connections
- Smart Equipment™ controls
- Powder paint tested to 750 salt spray hours
- Mechanical cooling from 40° F to 125° F
- 1-1/2" insulation
- Sloped unit roof with drip lip
- High and low refrigerant pressure protection
- Polyurethane sleeves to protect small diameter tubing
- Steel framing around blowers with deflection springs or rubber isolators for low vibration
- Fully factory packaged and run-tested
- 10 year gas heat exchanger warranty
- One year compressor warranty
- One year warranty on all parts

### Factory Installed Options

- Economizer with low leak dampers
- Retractable outside air hoods (economizer only)
- Natural gas standard or modulating gas heat with reliable induced draft design
- Electric heat in three sizes
- Variable air volume using wired for VFD (variable frequency drive), or factory installed VFD.
- 3 position (Line/Drive/Test) bypass switch for either supply or exhaust VFDs.
- 1, 2" blower isolator springs or rubber isolators
- A variety of blower horsepower offerings
- High efficiency motors
- High efficiency filtration
- Barometric relief
- Power exhaust of 100% of nominal air flow

- Technicoat corrosive resistant coating on condenser and evaporator coils
- Copper-Copper corrosive resistant condenser and evaporator coils
- 0°F low ambient operation of mechanical cooling
- Hot gas bypass (standard on all VAV units)
- Single unit disconnect
- Convenience outlet and transformer factory wired
- Hot water heating coil with one or two rows
- One row steam heating coil
- Verasys
- FDD (Fault Detection and Diagnostics) - Refrigerant side

### Field Installed Accessories

- 7-Day Programmable Wall Thermostat-Can be used with or without remote sensors. Can be used on CV and VAV units when wall thermostat is required for scheduling and temperature control.
- Energy Recovery Ventilators- 8,000 and 13,000 CFM models available. Great for applications involving 30% or more of required outdoor air where energy use and comfort must be optimized.
- Wall Sensors- Remote space sensors used with CV or VAV unit for unit control via the Smart Equipment™ control. Standard sensor, sensor with override and sensor with override and + 5 degree adjustment.
- Phase Monitor Kit- Includes control and wiring to monitor and protect the unit from phase reversal, phase loss and low voltage.
- Burglar Bars- Prevent any type of building entry through the RTU unit with bars that block the return and supply openings on downflow applications.
- Partial perimeter roofcurb- Designed for application on all 25-40 ton Millennium rooftop units. 14" height.
- Barometric Relief Kit- Provides barometric relief hood and dampers for duct mounting on units requiring end return.
- Natural Gas to Propane Conversion Kits- Contains orifices and gas valves parts to convert from Natural Gas to Propane. (Not available on modulating heat.)
- High Altitude Kit- Natural gas kit designed for natural gas heating applications between 2,000 and 6,000 feet above sea level.



# NOMENCLATURE

## Millennium™ Model Number Nomenclature 25-40 Ton Single Package

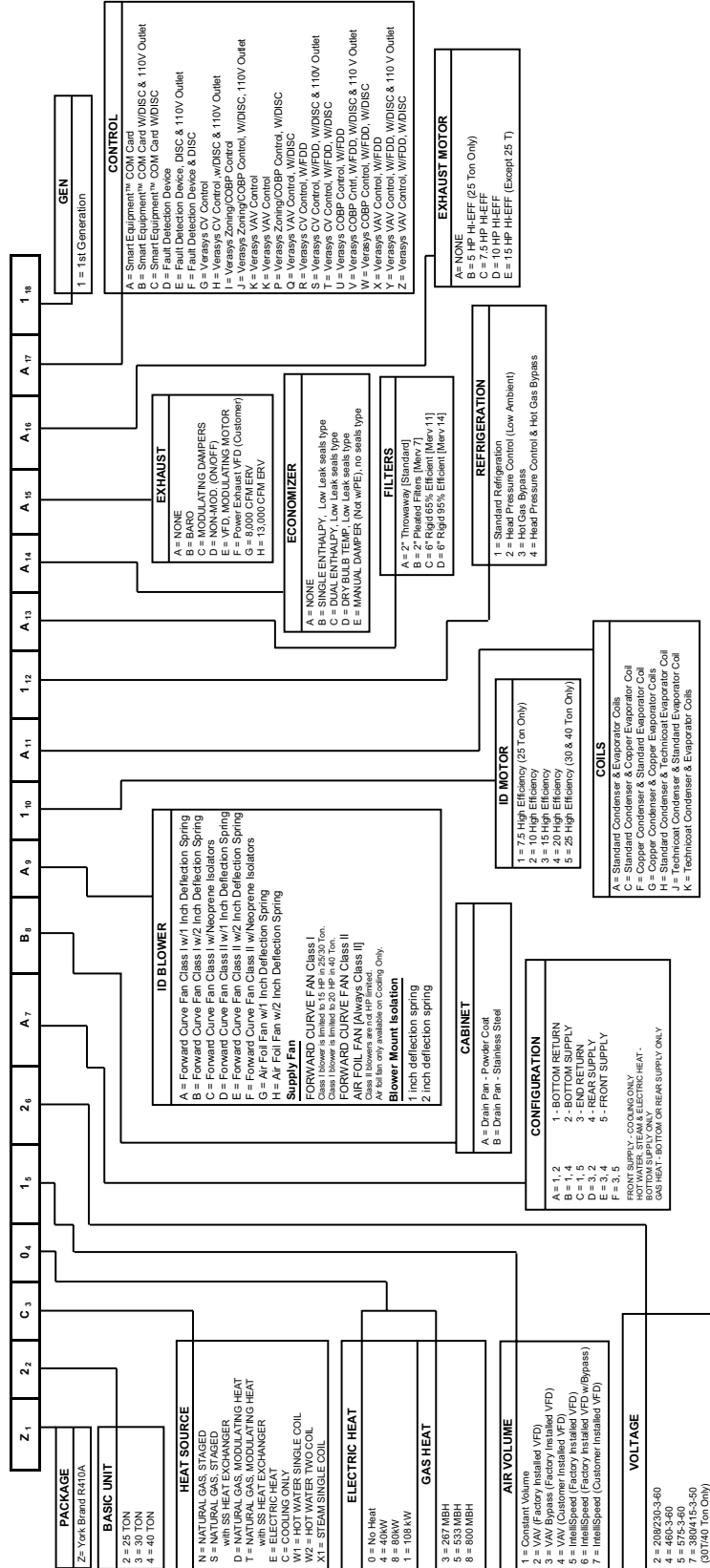

**TABLE 1: GENERAL PHYSICAL DATA**

UNIT SIZE	25 TON	30 TON	40 TON
UNIT EER	10.5	10.5	10.7
UNIT IEER CV	11.9	11.6	11.6
UNIT IEER DS (INTLLISPEED)	13.3	13.5	13.6
UNIT IEER VAV	13.8	13.5	13.6
<b>COMPRESSOR DATA</b>			
NUMBER/SIZE	4 x 5.7Ton	4 x 7 Ton	4 x 8.6 Ton
TYPE	Scroll	Scroll	Scroll
UNIT CAPACITY STEPS	25%, 50%, 75%, 100%	25%, 50%, 75%, 100%	25%, 50%, 75%, 100%
<b>INDOOR FAN AND DRIVE</b>			
NUMBER / TYPE	1 / FC	1 / FC	1 / FC
DIAMETER x WIDTH (INCHES)	22 x20	22 x 20	25 x 22
HP RANGE	7.5 - 20	10 - 25	10 - 25
CFM RANGE (FULL LOAD)	6,000 - 12,500	6,000 - 15,000	8,000 - 18,000
ESP RANGE	0.2" - 4.0"	0.2" - 4.0"	0.2" - 4.0"
<b>EXHAUST FAN</b>			
NUMBER/SIZE/TYPE	1/FC	2/FC	2/FC
HP RANGE (SINGLE MOTOR)	5 - 10	7.5 - 15	7.5 - 15
CFM	3,000 - 9,000	4,000 - 15,000	4,000 - 18,000
<b>EVAPORATOR COIL</b>			
SIZE (SQ. FT.)	26.0	26.0	30.4
ROWS/FPI	3 / 16	4 / 16	4 / 16
<b>CONDENSER COIL</b>			
SIZE (SQ. FT.)	65	104	104
ROWS/FPI	2/16	2 / 16	2 / 16
<b>CONDENSER FANS</b>			
QUANTITY / DIAMETER (INCHES)	4 / 24	4 / 30	4 / 30
NOMINAL CFM	6,800	8,770	9,460
MOTOR HP	1.0	1.5	1.5
<b>ELECTRIC HEAT</b>			
KW RANGE	40 - 108	40 - 108	40 - 108
40 kW / CAPACITY STEPS (CV/VAV)	1	1	1
80 kW / CAPACITY STEPS (CV/VAV)	2 / 1	2 / 1	2 / 1
108 kW / CAPACITY STEPS (CV/VAV)	3 / 1	3 / 1	3 / 1
<b>NATURAL GAS HEAT</b>			
UNIT SIZE	25 TON	30 TON	40 TON
267 MBH CAPACITY STEPS (CV/VAV)	1 / 1	1 / 1	1 / 1
533 MBH CAPACITY STEPS (CV/VAV)	2 / 1	2 / 1	2 / 1
800 MBH CAPACITY STEPS (CV/VAV)	-	-	3 / 1
267 MBH "MODULATING" CAPACITY STEPS (CV ONLY)	6 / 1	6 / 1	6 / 1
533 MBH "MODULATING" CAPACITY STEPS (CV ONLY)	12 / 2	12 / 2	12 / 2
800 MBH "MODULATING" CAPACITY STEPS (CV ONLY)	-	-	17 / 3
<b>HOT WATER COIL</b>			
SIZE (INCHES)	22.5" x 65"	22.5" X 65"	22.5" X 65"
CAPACITY	25 Ton	30 Ton	40 Ton
<b>STEAM COIL</b>			
SIZE (INCHES)		21" X 65"	
TYPE		Steam Coil	
<b>FILTERS 2" TA</b>			
NUMBER / SIZE	4 / 16 x 25 & 6 / 20 x 25	4 / 16 x 25 & 6 / 20 x 25	4 / 16 x 25 & 6 / 20 x 25
FACE AREA (SQ. FT.)	30.4	30.4	30.4
<b>FILTERS 2" PLEATED, 30%</b>			
NUMBER / SIZE	4 / 16 x 25 & 6 / 20 x 25	4 / 16 x 25 & 6 / 20 x 25	4 / 16 x 25 & 6 / 20 x 25
FACE AREA (SQ. FT.)	30.4	30.4	30.4
<b>FILTERS 65% RIGID W/ 2" TA PREFILTERS</b>			
NUMBER / SIZE	4 / 16 x 25 & 6 / 20 x 25	4 / 16 x 25 & 6 / 20 x 25	4 / 16 x 25 & 6 / 20 x 25
FACE AREA (SQ. FT.)	30.4	30.4	30.4
<b>FILTERS 95% RIGID W/ 2" TA PREFILTERS</b>			
NUMBER / SIZE	4 ea. 16 x 25 / 6 ea. 20 x 25	4 ea. 16 x 25 / 6 ea. 20 x 25	4 ea. 16 x 25 / 6 ea. 20 x 25
FACE AREA (SQ. FT.)	30.4	30.4	30.4

**TABLE 2: REFRIGERANT FACTORY CHARGE R-410A**

UNIT (Tons)	MODEL	CHARGE			
		SYSTEM #1	SYSTEM #2	SYSTEM #3	SYSTEM #4
25	w/o HGBP	13lb 8oz	12lb 8oz	12lb 8oz	12lb 8oz
25	w/ HGBP	14lb	12lb 8oz	12lb 8oz	12lb 8oz
30	w/o HGBP	22lb 15oz	20lb 7.5oz	22lb 4oz	20lb 6oz
30	w/ HGBP	23lb 7oz	20lb 7.5oz	22lb 4oz	20lb 6oz
40	w/o HGBP	20lb 8oz	18lb 8oz	18lb 8oz	20lb
40	w/ HGBP	21lb	18lb 8oz	18lb 8oz	20lb

**SELECTION PROCEDURE**

## GIVEN:

Required Cooling Capacity	460,000 Btuh
Required Sensible Cooling	390,000 Btuh
Required Heating (Gas)	320,000 Btuh
Entering Air on Evaporator	83° F DB/ 67° F WB
Outside Design Temperature	95° F
Supply Fan CFM	13,000 CFM
External Static Pressure	1.25 IWG
Electrical Supply Voltage	460-3-60
Economizer Required	
2" Throw Away Filters	
Constant Volume	

**SELECT UNIT:**

- Determine nominal tons:  
 $460,000 / 12,000 = 38.33$  Tons  
 Thus, a nominal 40 ton unit is selected.
- Reference Cooling Capacity Table for a 40 ton unit.
  - Locate the table for the 40 ton evaporator coil with 95° F air on the condenser.
  - Enter table at 13,000 CFM and 67°F WB air on evaporator
  - Trace to 83° F Entering Dry Bulb column.
  - Read 493 MBH total capacity and 403 MBH sensible capacity.

The 40 ton unit will meet the cooling requirements. From the nomenclature, the unit will be a Z4. Choose the appropriate configuration for the next digit. Assuming bottom return and supply, the fourth digit would be an "A," making the model Z4A.

- Find Gas Heating Capacity Table.
  - Trace down Output column.
  - Find output which exceeds 320,000 Btuh requirement. The N5 option gives 426 MBH output.

- Ensure that it is offered in the Z4 unit. Read option model as N5.

From the basic nomenclature, the model now becomes Z4AN5. Add voltage code of "4" for 460-3-60. Nomenclature becomes Z4AN44.

**SELECT FAN SPEED AND HORSEPOWER REQUIREMENTS OF SUPPLY AIR FAN**

- Find Supply Air Performance Tables for the 40 ton unit.
  - Check footnotes and make necessary additions or deductions to static resistance of ductwork:  
 Ductwork static resistance                      1.25 IWG  
 Economizer static resistance addition (interpolate) = .25 IWG + Gas Heat (High) = 0.5 IWG  
 Total Static Resistance                              2.0 IWG
- Enter Fan Performance Table at 13,000 CFM and 2.0 IWG static pressure:  
 RPM = 733  
 BHP = 11.8

**NOTE:** Either Class I or Class II blower could be used.

- Enter the Fan Motor Drive Tables. Selecting a 15 hp motor allows (service factor of 1.5) for a maximum operating BHP greater than the 11.8 BHP requirement.

**SIZE OVERCURRENT PROTECTION DEVICE AND DETERMINE CIRCUIT AMPACITY**

- Find electrical tables for the basic 40 ton unit.
  - Enter table for 460-3-60 voltage.
  - Find 15 hp in the Supply Air Fan column.
  - Trace to Minimum Circuit Ampacity column - read 105.
  - Trace to Max. Fuse/Breaker Size column - read 125 amps.
  - Size wire and overprotection device accordingly.
  - Check all footnotes.

**TABLE 3: STANDARD GAS HEATING CAPACITIES**

GAS HEAT OPTION	AVAILABLE ON MODELS	INPUT CAPACITY (MBH) <sup>1</sup>		OUTPUT CAPACITY (MBH) <sup>2</sup>	GAS RATE, CU. FT./HR. <sup>3</sup>	
		1ST STAGE	TOTAL		1ST STAGE	TOTAL
N3	Z2/Z3/Z4	267	267	213	247	247
N5	Z2/Z3/Z4	267	533	426	247	495
N8	Z4 ONLY	267 <sup>4</sup>	800	638	247	742

1. Heating capacity is only staged on CV models. VAV models use only one stage at full capacity.
2. Blower motor heat not included.
3. Based on a heat content of 1075 Btu/Ft.<sup>3</sup>

$$\text{GAS RATE} = \frac{\text{Input MBH}}{(1.075\text{MBH})/\text{Ft}}^3$$

4. Unit Control Board with 3 heating outputs only. For all other Unit Control Boards the 1st Stage is 533 MBH.

**TABLE 4: TEMPERATURE RISE**

TON	MODULES		
	1	2	3
25	5-35	25-55	-
30	5-35	20-50	-
40	5-30	10-45	25-55

**TABLE 5: MINIMUM HEATING CFM**

TON	MODULES		
	1	2	3
25	5,644	7,183	-
30	5,644	7,901	-
40	6,584	8,779	13,169

**TABLE 6: MODULATING GAS HEATING CAPACITIES**

GAS HEAT OPTION	AVAILABLE ON MODELS	INPUT CAPACITY (MBH)		STEPS	OUTPUT CAPACITY (MBH) <sup>1</sup>	GAS RATE, CU. FT./HR.	
		MINIMUM	MAXIMUM			MINIMUM	MAXIMUM
D3 <sup>2</sup>	Z2/Z3/Z4	69	267	6	213	64	247
D5 <sup>2</sup>	Z2/Z3/Z4	69	533	12	426	64	495
D8 <sup>2</sup>	Z4 ONLY	69	800	17	638	64	744

1. Output Capacity at Full Fire.
2. Modulating Gas Heat available on CV models only.

TABLE 7: MODULATING HEAT

STAGES OF GAS CONTROL (% OF FULL HEAT OUTPUT)					
GAS HEAT OPTION	AVAILABLE ON MODELS	STEP	INPUT	OUTPUT	% OF TOTAL OUTPUT
D3 (Turn down ratio 3.8 to 1)	Z2, Z3, Z4	1	69,333	55,466	26%
		2	106,666	85,333	40%
		3	165,332	132,266	62%
		4	202,665	162,132	76%
		5	229,332	183,466	86%
		6	266,666	213,333	100%
D5 (Turn down ratio 7.7 to 1)	Z2, Z3, Z4	1	69,333	55,466	13%
		2	106,666	85,333	20%
		3	165,332	132,266	31%
		4	202,665	162,132	38%
		5	229,332	183,466	43%
		6	266,666	213,333	50%
		7	325,331	260,265	61%
		8	362,664	290,132	68%
		9	389,331	311,465	73%
		10	426,664	341,331	80%
		11	495,997	396,798	93%
		12	533,330	426,664	100%
D8 (Turn down ratio 11.5 to 1)	Z4 Only	1	69,333	55,466	9%
		2	106,666	85,333	13%
		3	165,332	132,266	21%
		4	202,665	162,132	25%
		5	229,332	183,466	29%
		6	266,666	213,333	33%
		7	325,331	260,265	41%
		8	362,664	290,132	45%
		9	389,331	311,465	49%
		10	426,664	341,331	53%
		11	495,997	396,798	62%
		12	533,330	426,664	67%
		13	586,663	469,330	73%
		14	655,996	524,797	82%
		15	693,329	554,663	87%
		16	762,662	610,130	95%
		17	799,995	639,996	100%

TABLE 8: ELECTRIC HEATING CAPACITIES

ELECTRIC HEAT OPTION	AVAILABLE ON MODELS	RATED VOLTAGE	NOMINAL KW	NOMINAL MBH <sup>1</sup>	MBH AND KW PER STAGE <sup>2</sup>			
					STAGE 1		STAGE 2	
					KW	MBH	KW	MBH
E4	Z2, Z3, Z4	240 <sup>3</sup> /480 <sup>4</sup> / 575	40	137	40	137	0	0
E8	Z2, Z3, Z4	240 <sup>2</sup> /480 <sup>3</sup> / 575	80	273	40	137	40	137
E1	Z2, Z3, Z4 (460 & 575 volt only)	480 <sup>3</sup> /575	108	369	72	246	36	123

- Supply air fan motor heat not included.
- Heating capacity is only staged on CV models. VAV models use only one stage at full capacity.
- For 208 volts, multiply kW and MBH values by .751. For 230 volts, multiply kW and MBH values by .918
- For 460 volts, multiply kW and MBH values by .918.

## HOT WATER HEATING<sup>1</sup>

The YORK Millennium Rooftop units (30 - 40 Ton sizes) can be furnished with a YORK hot water coil as the source of heat (Bottom Supply Only). A one or two row coil will be factory installed in the heating section downstream of the supply air fan and just above the supply air opening in the bottom of the unit.

The hot water control valve will not be provided. The installer will need to field supply a water valve. The installer must also connect the hot water piping, and valve wiring at the job site for the hot water heat section to be operational.

For all hot water coils the entering water temperature should not exceed 200°F.

### PHYSICAL DATA HOT WATER COIL - 1 ROW

Coil Casing . . . . .	Galvanized Steel
Coil Construction . . . . .	Al Fin / Cu. Tube
Rows Deep . . . . .	1
Fin Thickness . . . . .	.006"
Tube Wall . . . . .	.016"
Tubes / Circuit . . . . .	2
Fins Per Inch . . . . .	8
Tubes High . . . . .	22.50"
Tube Length . . . . .	65"
Face Area . . . . .	10.16ft. <sup>2</sup>
Weight . . . . .	.71lbs.
Operating Weight . . . . .	.83lbs.

**TABLE 9: WATER PRESSURE DROP (1 ROW, 25 & 30 TON)**

GPM	10	20	30	40
<b>WATER PRESSURE DROP</b>	0.9	3.0	6.0	10.0

**TABLE 10: STATIC RESISTANCE HOT WATER COIL (25 & 30 TON)**

CFM	6000	8000	10000	15000
<b>AIR PRESSURE DROP 1 ROW</b>	0.07	0.11	0.16	0.32
<b>AIR PRESSURE DROP 2 ROW</b>	0.14	0.23	0.33	0.65

**NOTE:** Water pressure drop numbers are based on 60°F entering air temperature, 2.00" maximum air pressure drop across the hot water coil(s). AHRI certified ratings at other conditions are available upon request. Hot water coils are approved for use with glycol (rates available upon request).

1. Hot water, steam or electric heat is not available for front or rear supply.

## ▲ WARNING

DO NOT use tin based solder. Brazing with tin based solder could cause equipment damage or possible injury to OCCUPANTS of the structure that is being conditioned.

**TABLE 11: HOT WATER COIL (1 ROW, 25 & 30 TON)<sup>1</sup>**

GPM	CFM	CAPACITY (MBH) AT ENTERING WATER TEMPERATURE			
		140 °F	160 °F	180 °F	200 °F
10	6000	91.4	115.3	139.3	163.6
	8000	102	128.8	155.8	182.9
	10000	110.4	139.5	168.8	198.4
	12000	117.3	148.4	179.6	211.2
	15000	125.9	159.2	192.9	226.9
20	6000	103	129.4	156	182.7
	8000	116.8	147	177.2	207.7
	10000	128.2	161.3	194.7	228.2
	12000	137.8	173.6	209.5	245.6
	15000	150	189	228.2	267.8
30	6000	107.6	135	162.5	190.1
	8000	122.8	154.3	185.8	217.5
	10000	135.5	170.3	205.1	240.2
	12000	146.4	184	221.8	259.7
	15000	160.3	201.6	243	284.8
40	6000	110.1	138	166	194.1
	8000	126.1	158.2	190.5	222.8
	10000	139.6	175.2	210.9	246.8
	12000	151.2	189.8	228.5	267.5
	15000	166.1	208.6	251.3	294.1

1. Based on 60°F entering air temperature, 2.00" maximum pressure drop across the hot water coil.

### PIPING CONNECTIONS

The hot water piping must enter the unit through the floor of the heat section compartment. The access doors to the compartment are gasketed so the compartment can be sealed. However, as added protection for water leakage into the space, the piping access holes should be sealed with a heat resistant mastic (see the following illustration for approximate location of the compartment and piping connections).

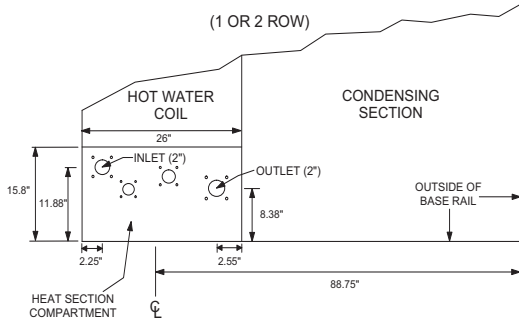

**FIGURE 1 - HOT WATER PIPING CROSS-SECTION**

**TABLE 12: STATIC RESISTANCE HOT WATER COIL (1 ROW, 40 TON)**

CFM	8000	11000	14000	20000
AIR PRESSURE DROP 1 ROW	0.11	0.19	0.29	0.52
AIR PRESSURE DROP 2 ROW	0.23	0.39	0.58	1.06

**TABLE 13: HOT WATER COIL (1 ROW 40 TON)<sup>1</sup>**

GPM	CFM	CAPACITY (MBH) AT ENTERING WATER TEMPERATURE			
		140 °F	160 °F	180 °F	200 °F
10	8000	102	128.8	155.8	182.9
	11000	114	144.1	174.4	205.1
	14000	123.2	155.9	188.8	222.1
	17000	130.6	165.4	200.4	235.8
	20000	136.8	173.3	210.1	247.3
20	8000	116.8	147	177.2	207.7
	11000	133.2	167.7	202.3	237.2
	14000	146.2	184.2	222.4	260.8
	17000	157	197.9	239	280.5
30	8000	122.8	154.3	185.8	217.5
	11000	141.2	177.4	213.8	250.3
	14000	155.9	196.1	236.4	276.9
	17000	168.3	211.8	255.4	299.3
40	8000	179.1	225.3	271.8	318.6
	11000	126.1	158.2	190.5	222.8
	14000	145.6	182.7	220	257.5
	17000	161.4	202.6	244.1	285.8
	20000	174.7	219.5	264.5	309.7
	20000	186.3	234.2	282.3	330.6

<sup>1</sup>. Based on 60°F entering air temperature, 2.00" maximum pressure drop across the hot water coil.

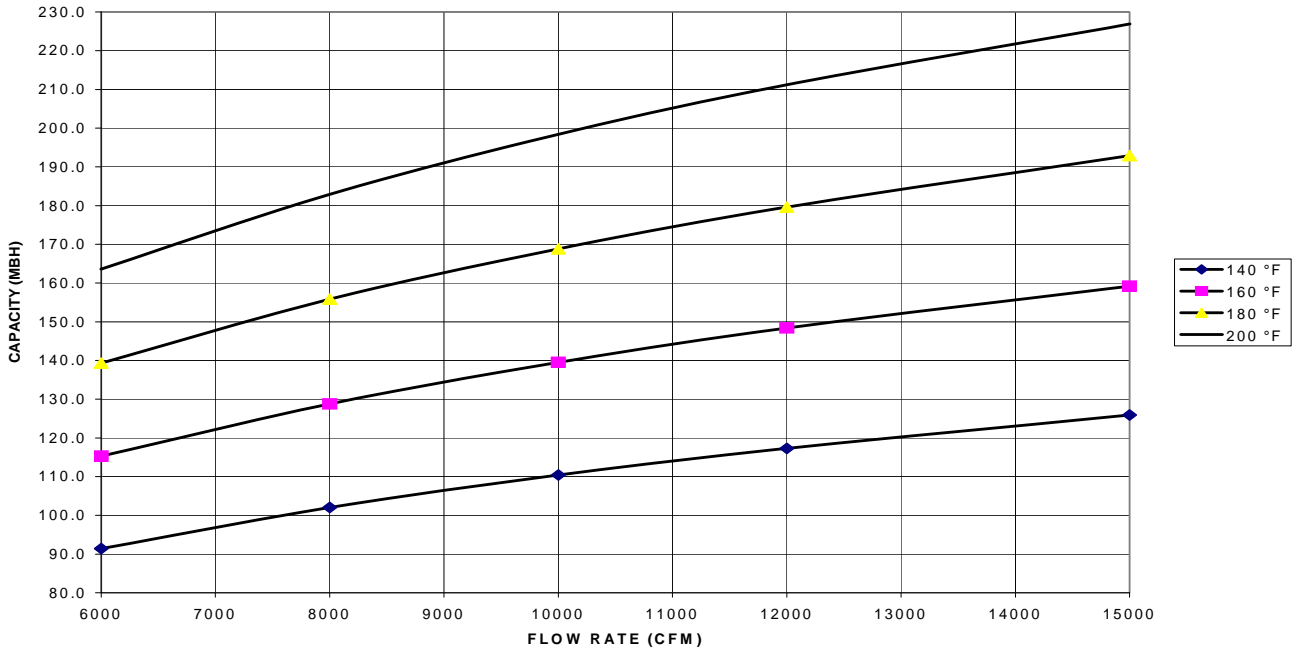

FIGURE 2 - HOT WATER COIL - 25 & 30 TON, 1 ROW, AT 10 GPM

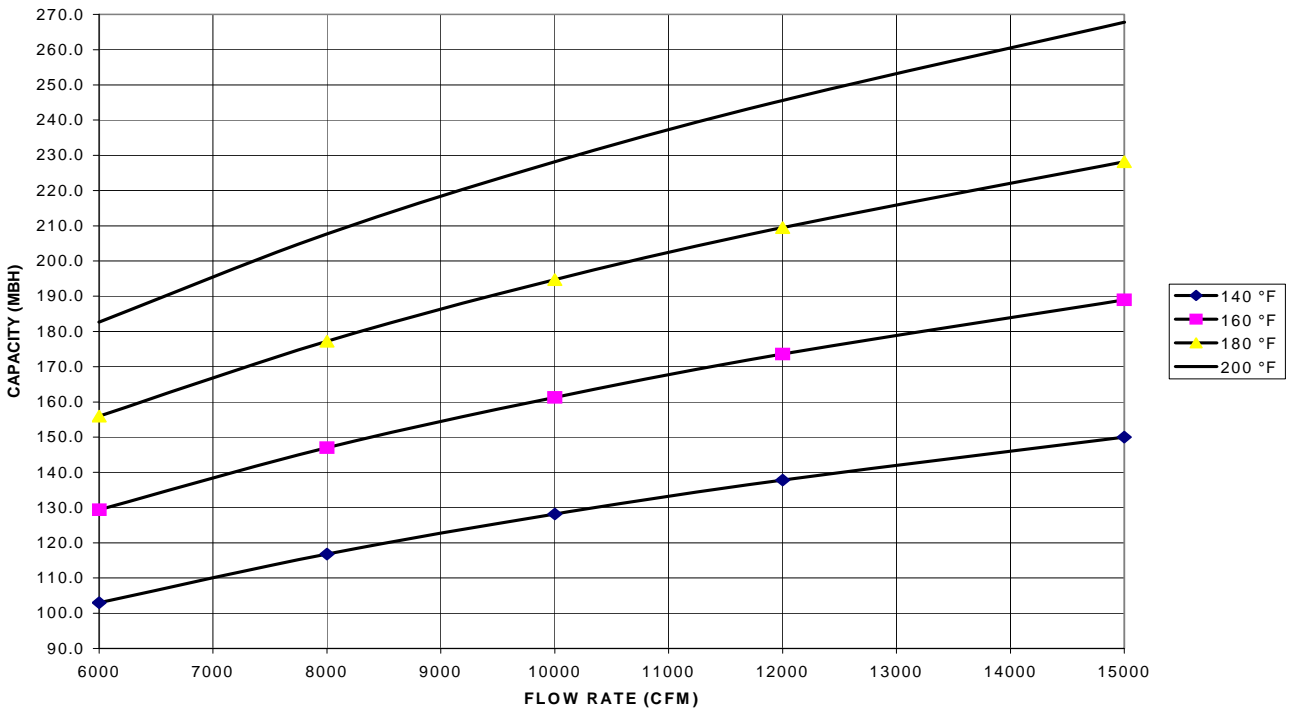

FIGURE 3 - HOT WATER COIL - 25 & 30 TON, 1 ROW, AT 20 GPM



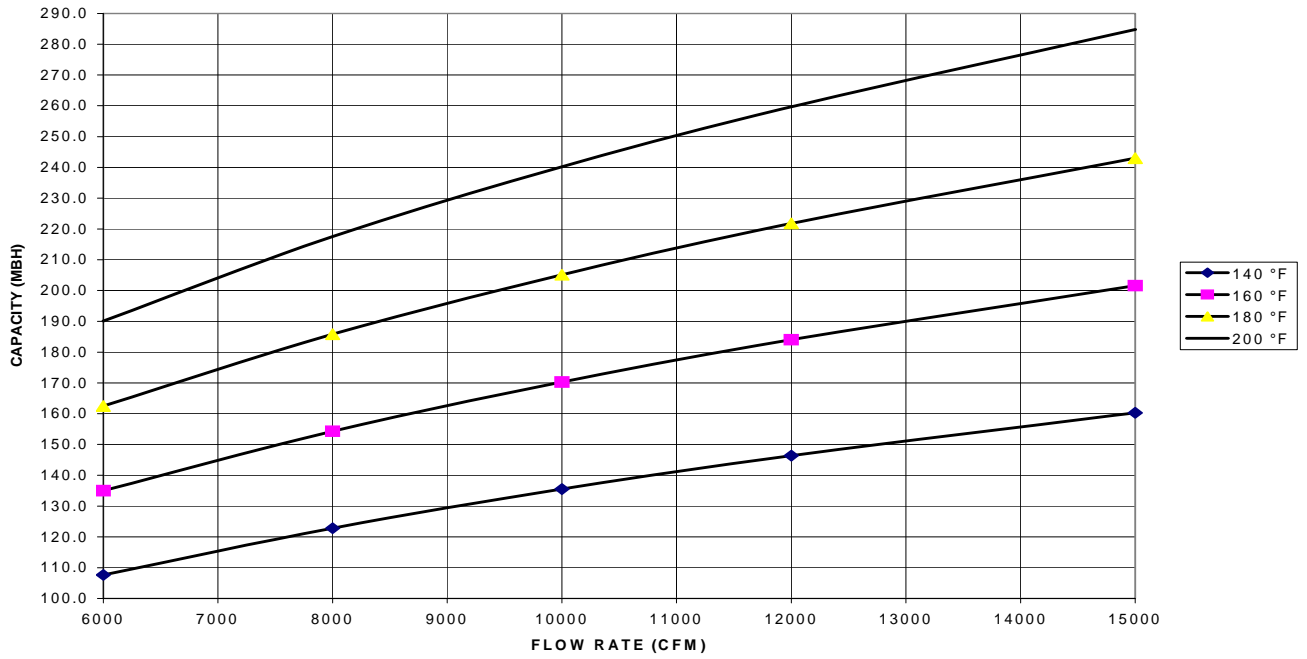

FIGURE 4 - HOT WATER COIL - 25 & 30 TON, 1 ROW, AT 30 GPM

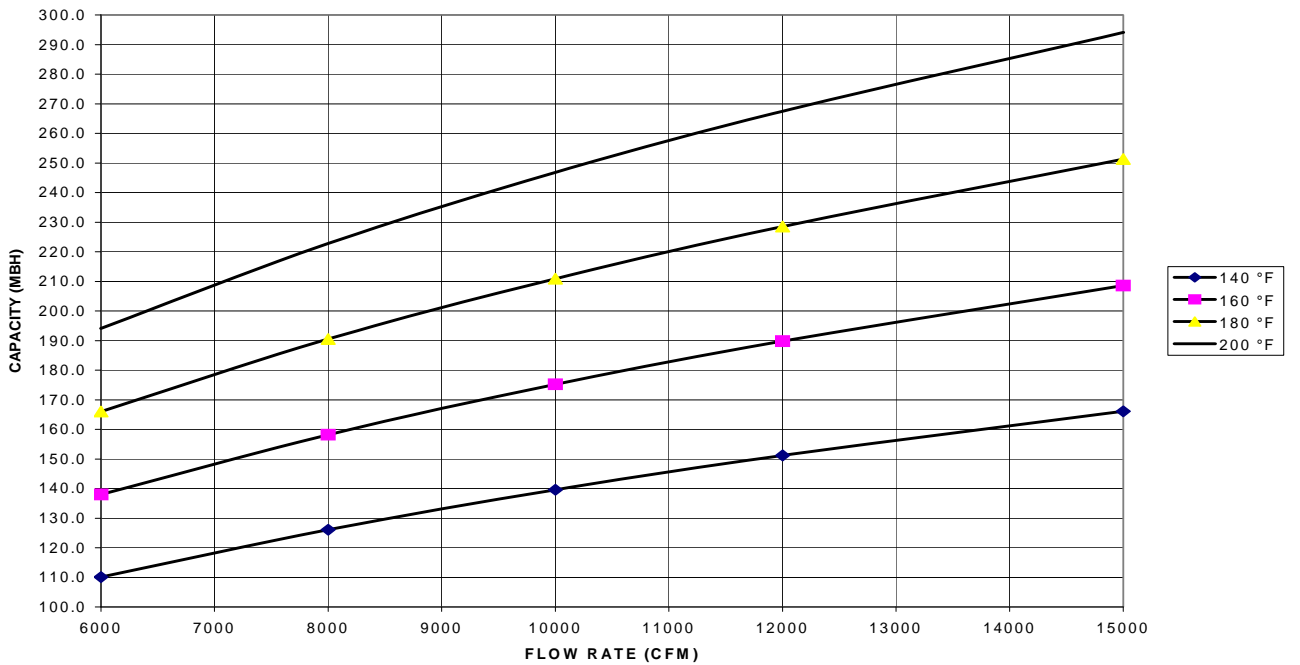

FIGURE 5 - HOT WATER COIL - 25 & 30 TON, 1 ROW, AT 40 GPM

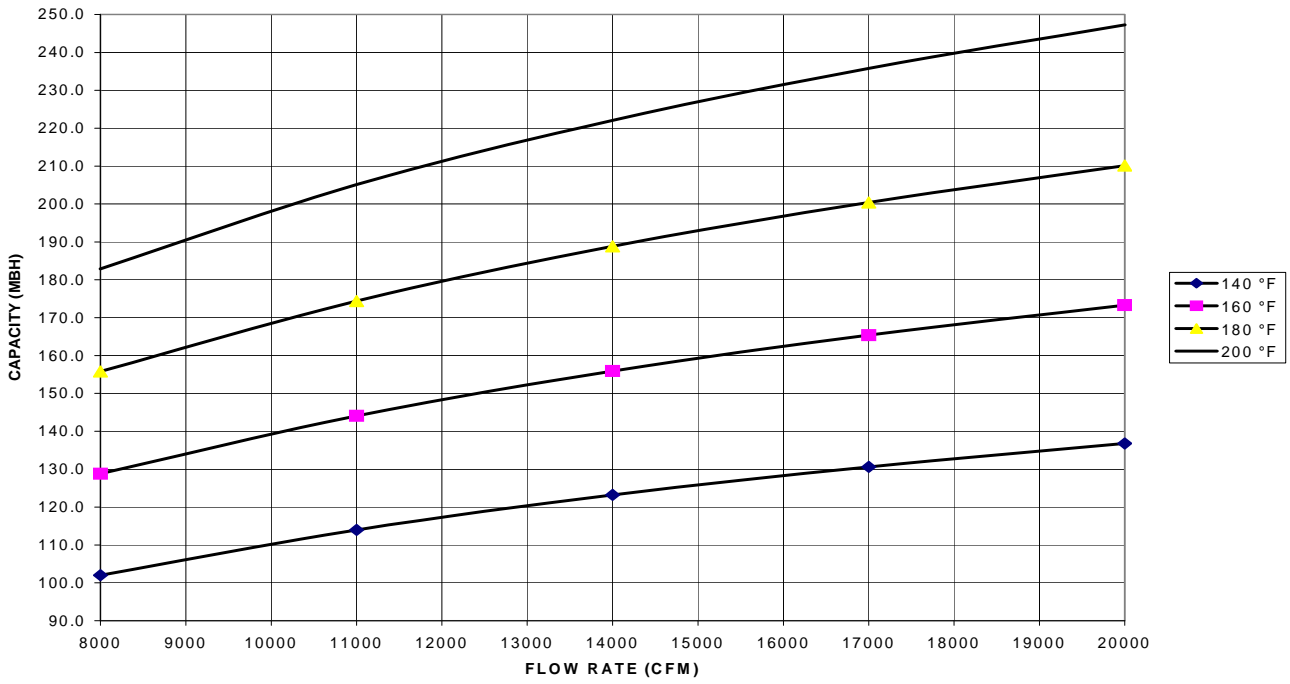

FIGURE 6 - HOT WATER COIL - 40 TON, 1 ROW, AT 10 GPM

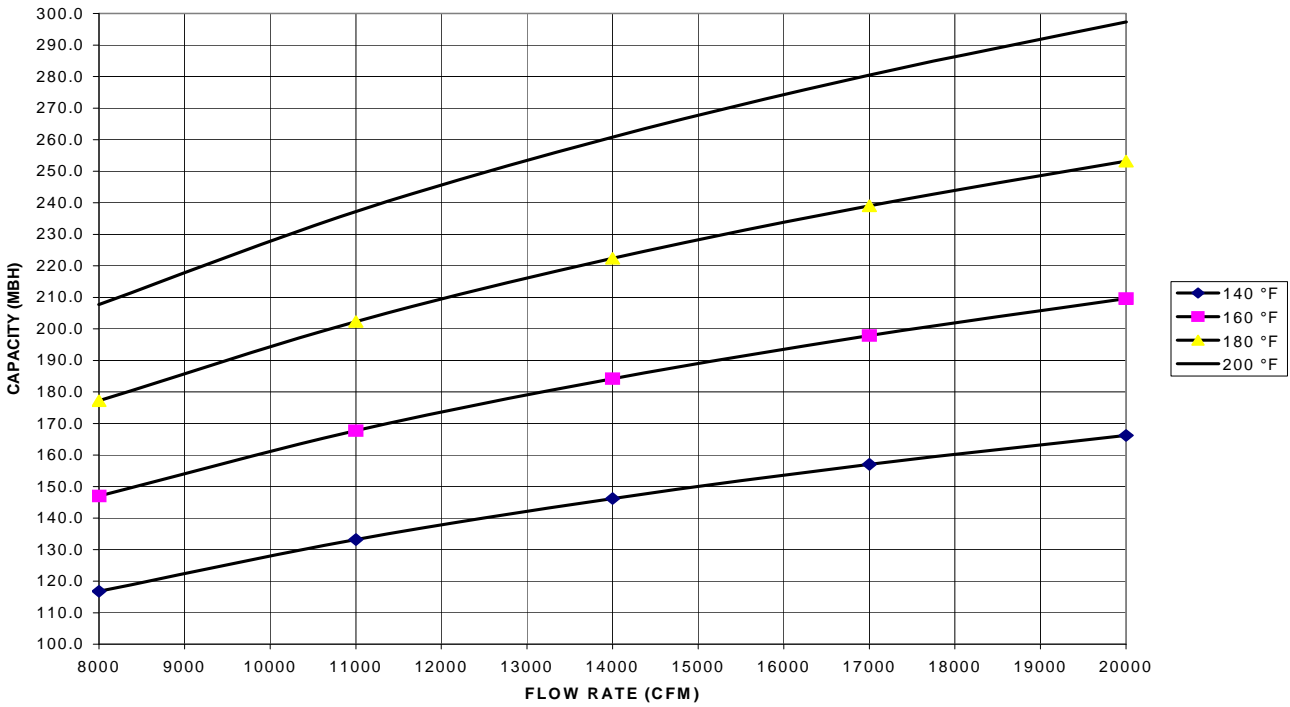

FIGURE 7 - HOT WATER COIL - 40 TON, 1 ROW, AT 20 GPM

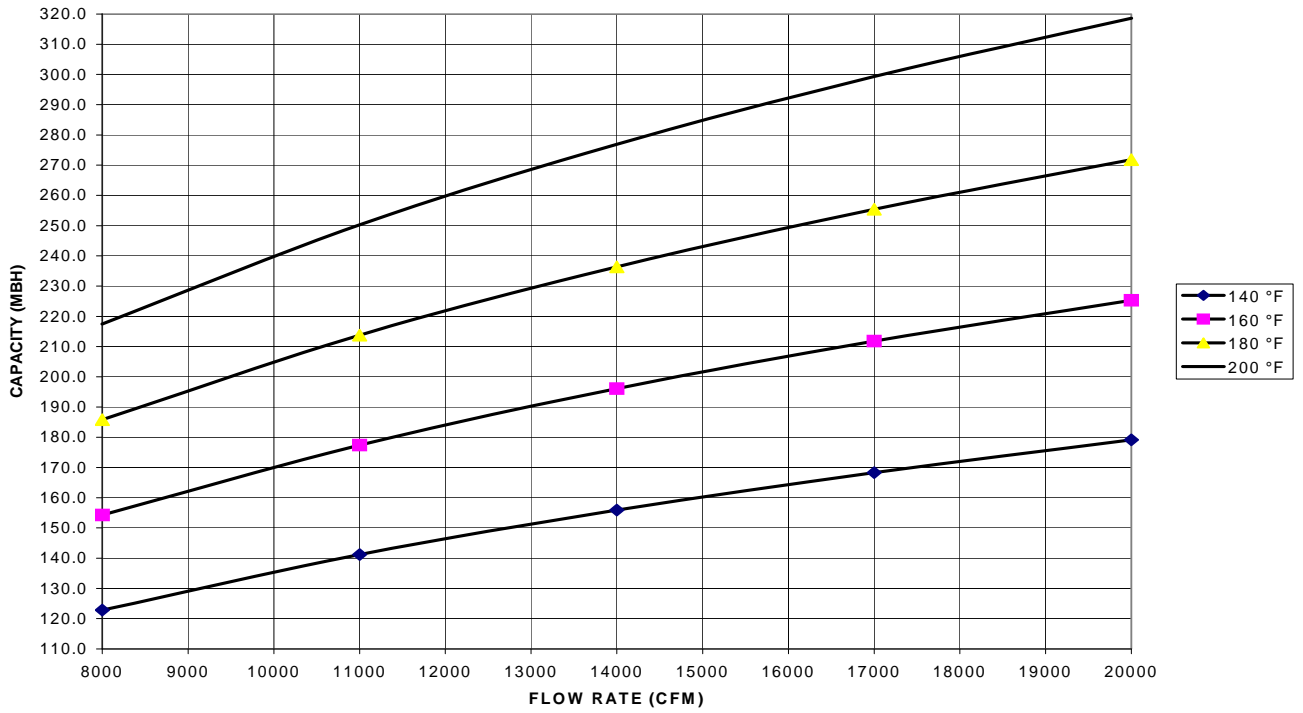

FIGURE 8 - HOT WATER COIL - 40 TON, 1 ROW, AT 30 GPM

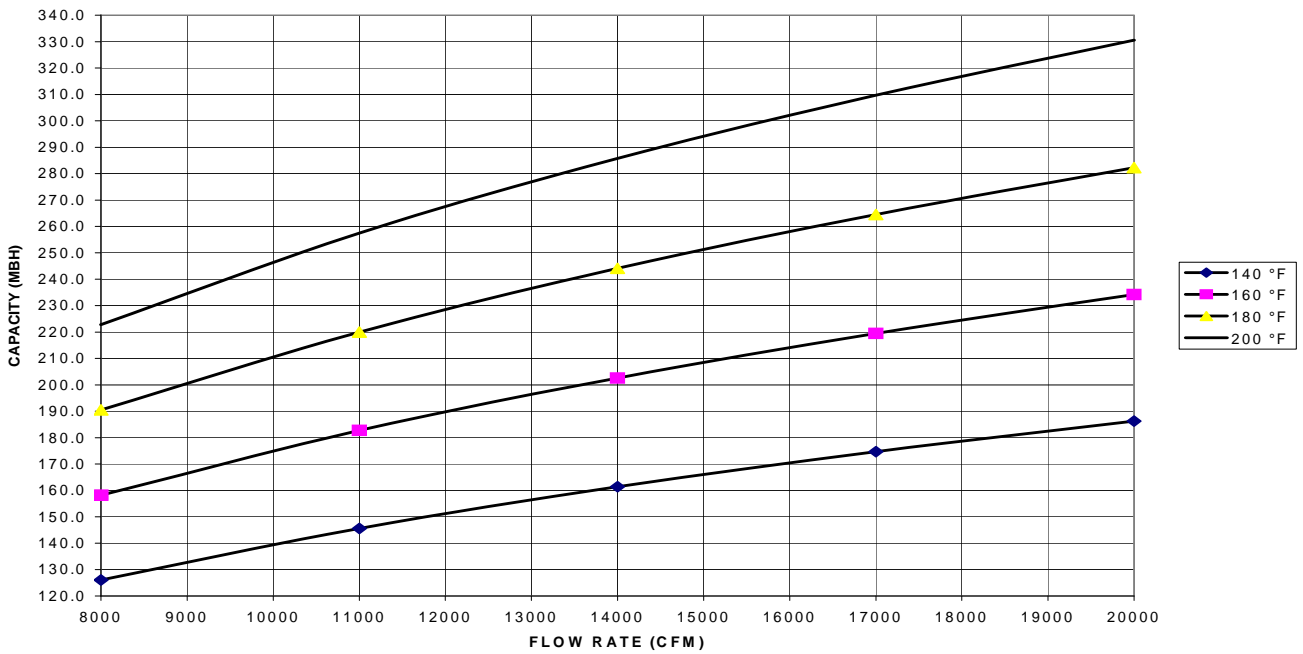

FIGURE 9 - HOT WATER COIL - 40 TON, 1 ROW, AT 40 GPM

**PHYSICAL DATA HOT WATER COIL - 2 ROW**

Coil Casing . . . . . Galvanized Steel  
 Coil Construction . . . . . Al Fin / Cu. Tube  
 Rows Deep . . . . . 2  
 Fin Thickness . . . . . .006"  
 Tube Wall . . . . . .016"  
 Tubes / Circuit . . . . . 2  
 Fins Per Inch . . . . . 8  
 Tubes High . . . . . 22.50"  
 Tube Length . . . . . 65"  
 Face Area . . . . . 10.16 ft.<sup>2</sup>  
 Weight . . . . . 90 lbs  
 Operating Weight . . . . . 110 lbs

**TABLE 14: WATER PRESSURE DROP (2 ROW, 25 & 30 TON)**

GPM	20	40	60	80
<b>WATER PRESSURE DROP</b>	0.9	3.0	6.0	10.0

**TABLE 15: STATIC RESISTANCE HOT WATER COIL (25 & 30 TON)**

CFM	6000	8000	10000	15000
<b>AIR PRESSURE DROP 1 Row</b>	0.07	0.11	0.16	0.32
<b>AIR PRESSURE DROP 2 Row</b>	0.14	0.23	0.33	0.65

**NOTE:** Water pressure drop numbers are based on 60°F entering air temperature, 2.00" maximum air pressure drop across the hot water coil(s). AHRI certified ratings at other conditions are available upon request. Hot water coils are approved for use with glycol (rates available upon request.)

**TABLE 16: HOT WATER COIL (2 ROW, 25 & 30 TON)<sup>1</sup>**

GPM	CFM	CAPACITY (MBH) AT ENTERING WATER TEMPERATURE			
		140 °F	160 °F	180 °F	200 °F
20	6000	177.5	223.8	270.4	317.3
	8000	203.8	257.2	311.1	365.5
	10000	224.8	284.1	343.9	404.2
	12000	242.2	306.4	371.1	436.4
	15000	263.6	333.8	404.6	476.1
40	6000	198.1	248.9	300.0	351.3
	8000	232.2	292.0	352.2	412.7
	10000	260.7	328.1	395.9	464.1
	12000	285.0	359.0	433.4	508.3
	15000	316.0	398.4	481.3	564.8

**TABLE 16: HOT WATER COIL (2 ROW, 25 & 30 TON)<sup>1</sup>(CONT.)**

GPM	CFM	CAPACITY (MBH) AT ENTERING WATER TEMPERATURE			
		140 °F	160 °F	180 °F	200 °F
60	6000	206.1	258.7	311.4	364.2
	8000	243.6	305.9	368.4	431.1
	10000	275.3	345.9	416.8	488.0
	12000	302.9	380.7	458.9	537.6
	15000	338.4	425.7	513.4	601.7
80	6000	210.5	263.9	317.4	371.1
	8000	249.8	313.3	377.1	441.1
	10000	283.3	355.6	428.2	501.0
	12000	312.7	392.7	473.0	553.6
	15000	351.0	440.9	531.3	622.1

<sup>1</sup>. Based on 60°F entering air temperature, 2.00" maximum pressure drop across the hot water coil.

**TABLE 17: HOT WATER COIL (2 ROWS, 40 TON)<sup>1</sup>**

GPM	CFM	CAPACITY (MBH) AT ENTERING WATER TEMPERATURE			
		140 °F	160 °F	180 °F	200 °F
20	8000	203.8	257.2	311.1	365.5
	11000	233.9	295.7	358.1	421.0
	14000	257.0	325.3	394.2	463.8
	17000	275.5	349.0	423.3	498.3
	20000	290.9	368.7	447.4	526.9
40	8000	232.2	292.0	352.2	412.7
	11000	273.3	344.1	415.3	487.0
	14000	306.3	386.0	466.3	547.1
	17000	333.9	421.1	508.9	597.3
	20000	357.5	451.1	545.4	640.5
60	8000	243.6	305.9	368.4	431.1
	11000	289.5	363.9	438.5	513.6
	14000	327.2	411.5	496.3	581.5
	17000	359.2	452.0	545.3	639.2
	20000	386.9	487.1	587.9	689.4
80	8000	249.8	313.3	377.1	441.1
	11000	298.5	374.7	451.2	528.1
	14000	338.9	425.7	512.8	600.5
	17000	373.4	469.3	565.6	662.5
	20000	403.6	507.5	611.8	716.8

<sup>1</sup>. Based on 60°F entering air temperature, 2.00" maximum air pressure drop across the hot water coil. AHRI certified ratings at other conditions available upon request. Hot water coils are approved for use with glycol (ratings available upon request).

**TABLE 18: STATIC RESISTANCE HOT WATER COIL (40 TON)**

CFM	8000	11000	14000	20000
<b>AIR PRESSURE DROP 1 Row</b>	0.11	0.19	0.29	0.52
<b>AIR PRESSURE DROP 2 Row</b>	0.23	0.39	0.58	1.06

**TABLE 19: WATER PRESSURE DROP (2 ROW, 40 TON)**

GPM	20	40	60	80
<b>WATER PRESSURE DROP</b>	0.9	3.0	6.0	10.0

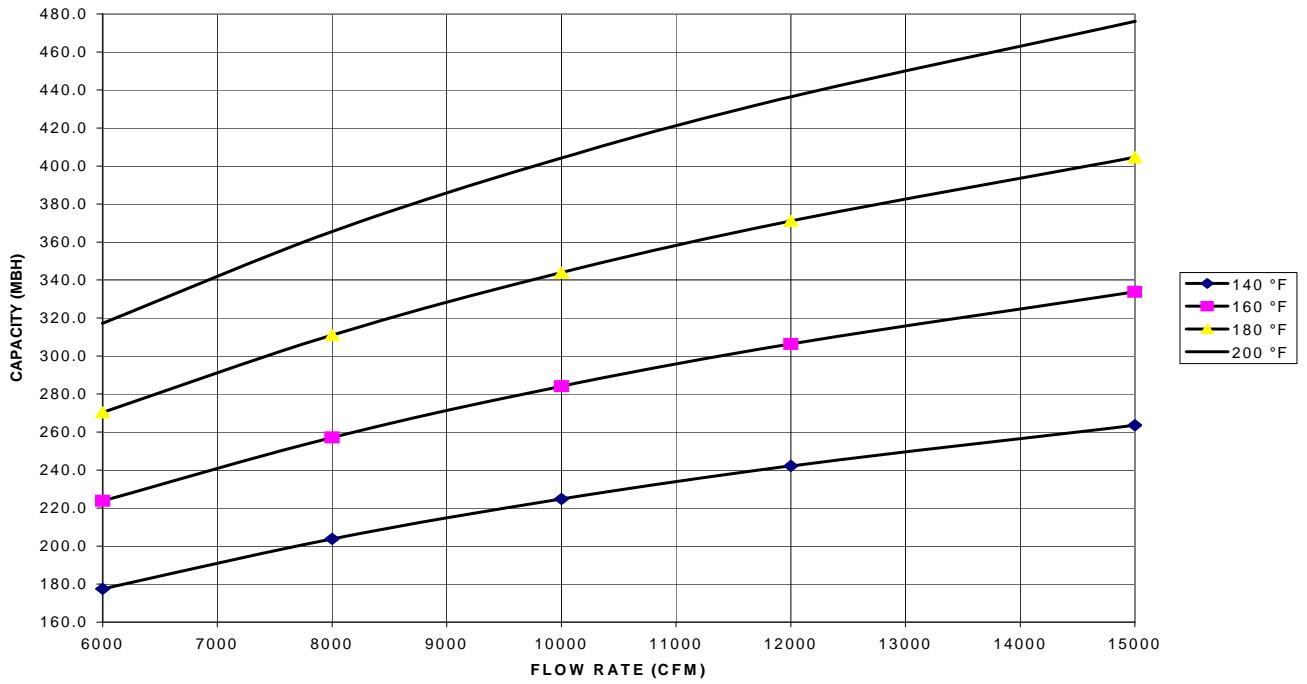

FIGURE 10 - HOT WATER COIL - 25 & 30 TON, 2 ROW, AT 20 GPM

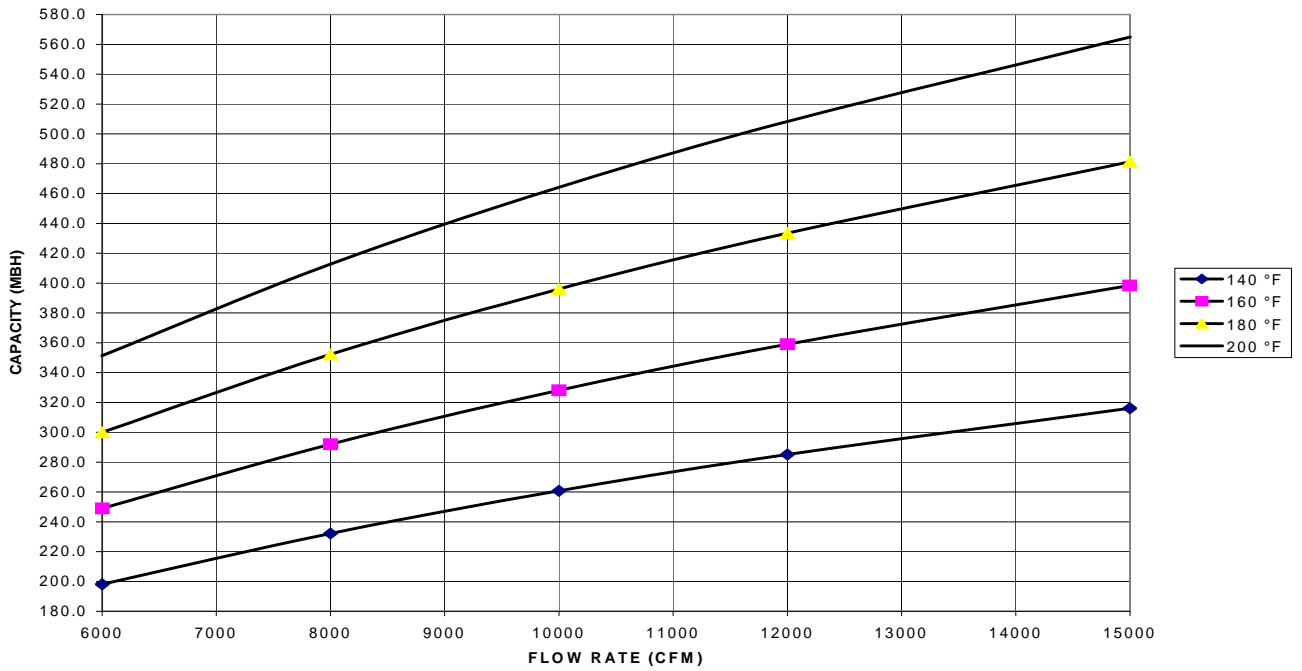

FIGURE 11 - HOT WATER COIL - 25 & 30 TON, 2 ROW, AT 40 GPM

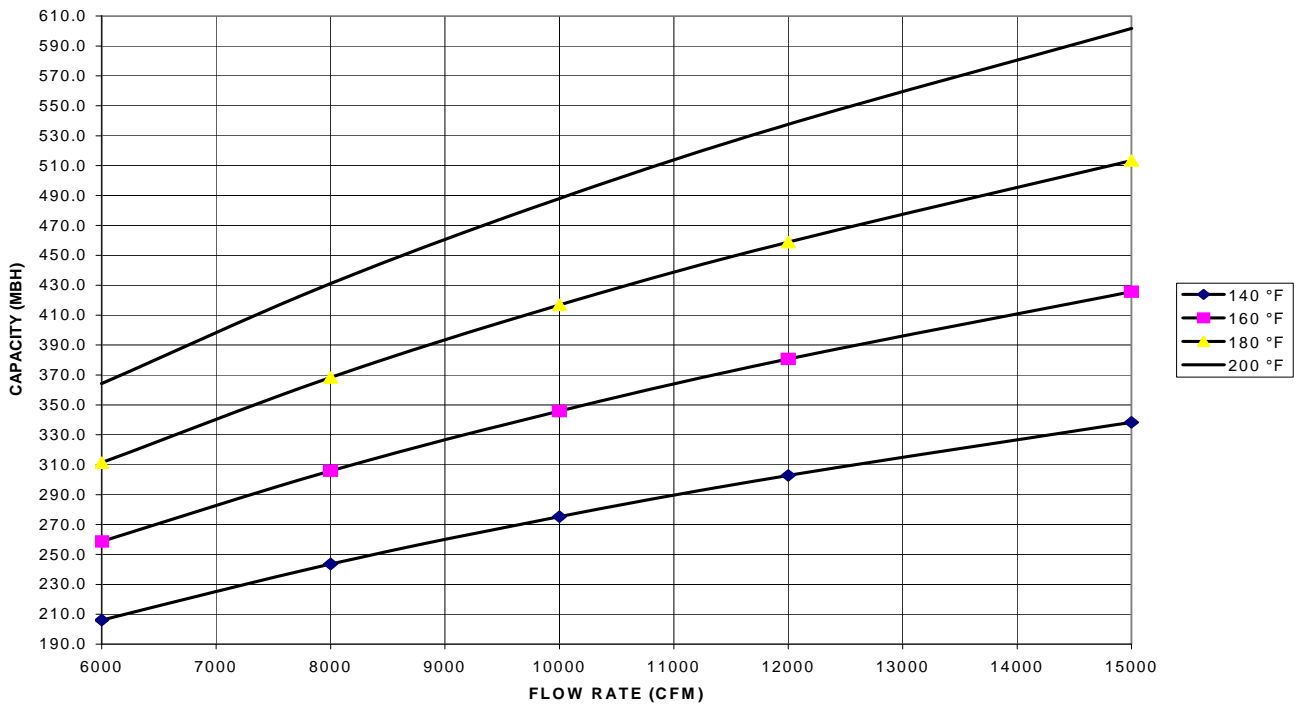

FIGURE 12 - HOT WATER COIL - 25 & 30 TON, 2 ROW, AT 60 GPM

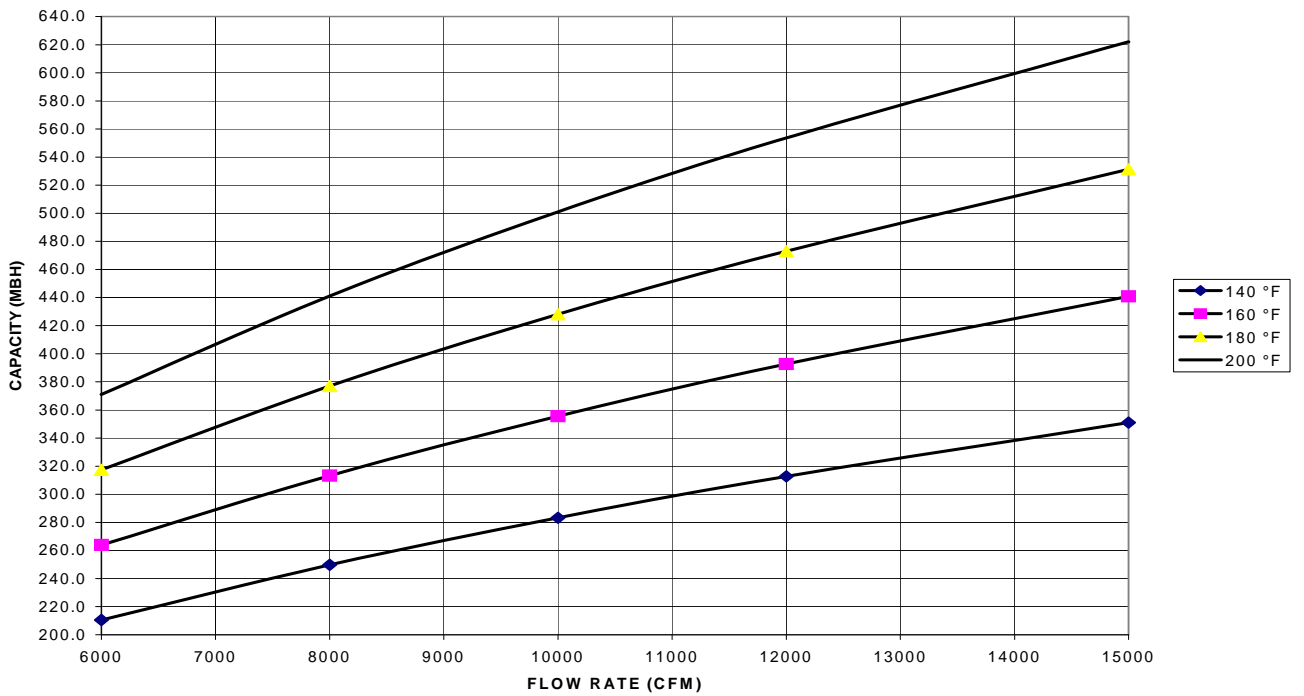

FIGURE 13 - HOT WATER COIL - 25 & 30 TON, 2 ROW, AT 80 GPM

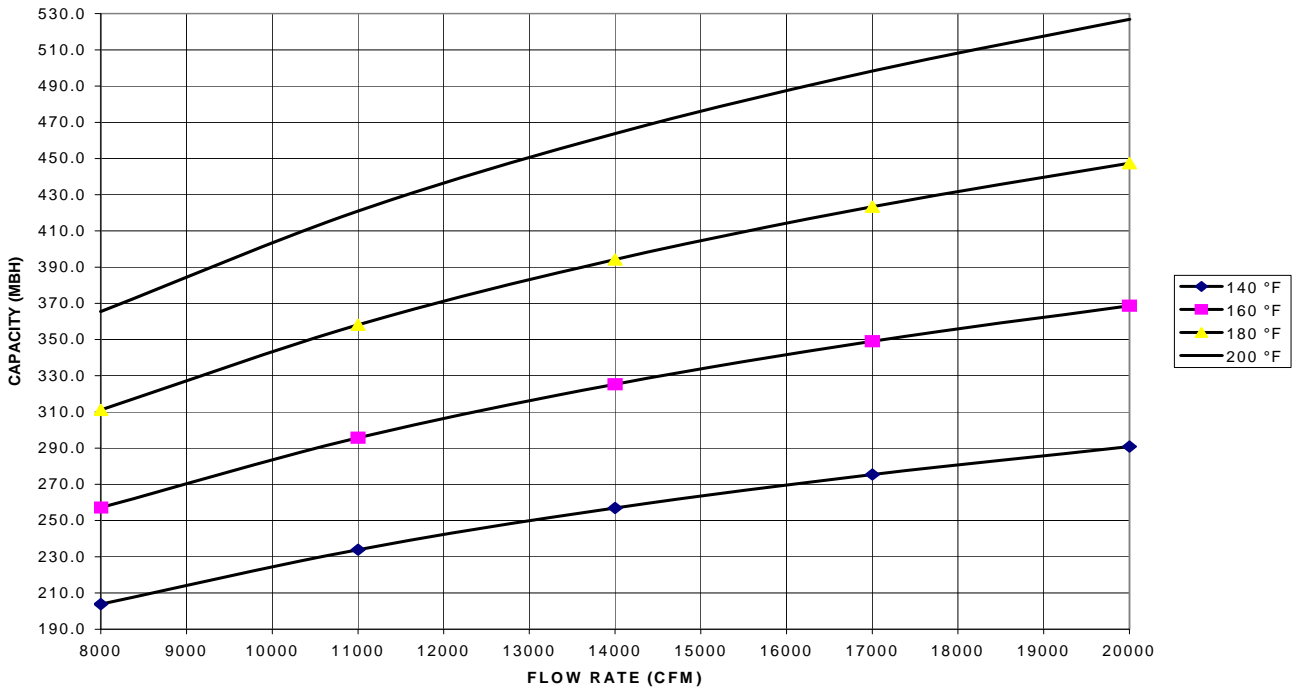

FIGURE 14 - HOT WATER COIL - 40 TON, 2 ROW, AT 20 GPM

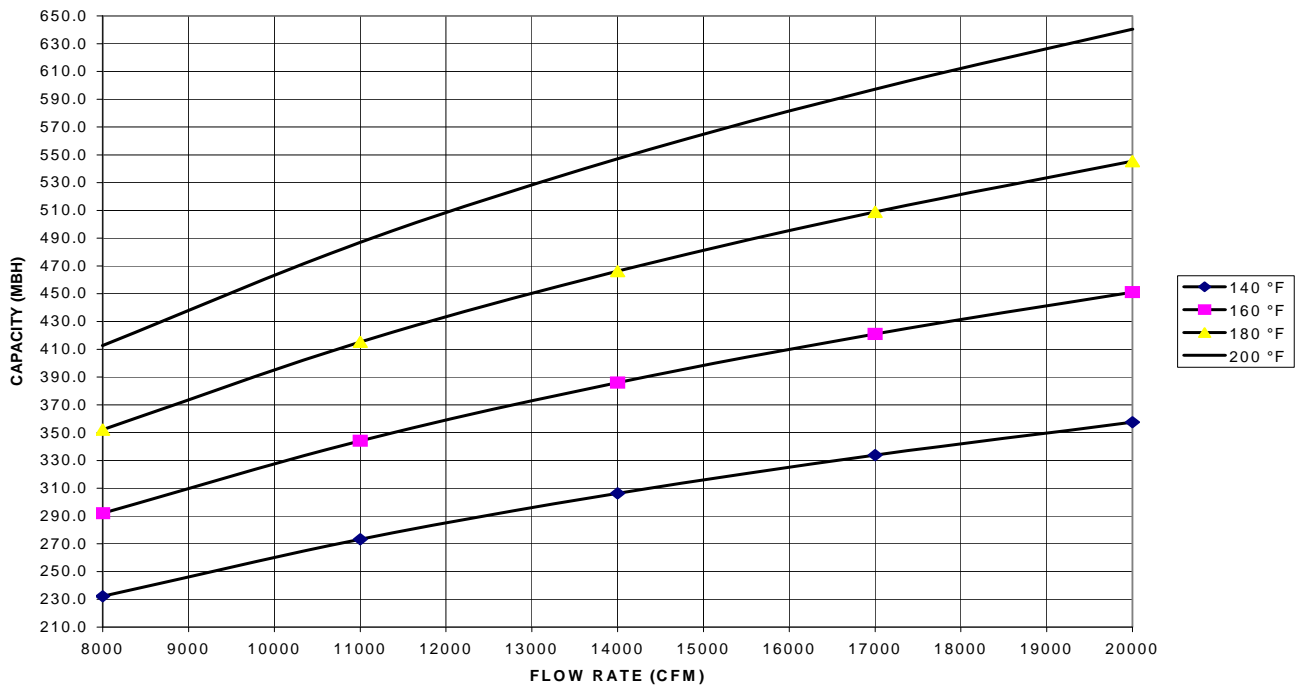

FIGURE 15 - HOT WATER COIL - 40 TON, 2 ROW, AT 40 GPM

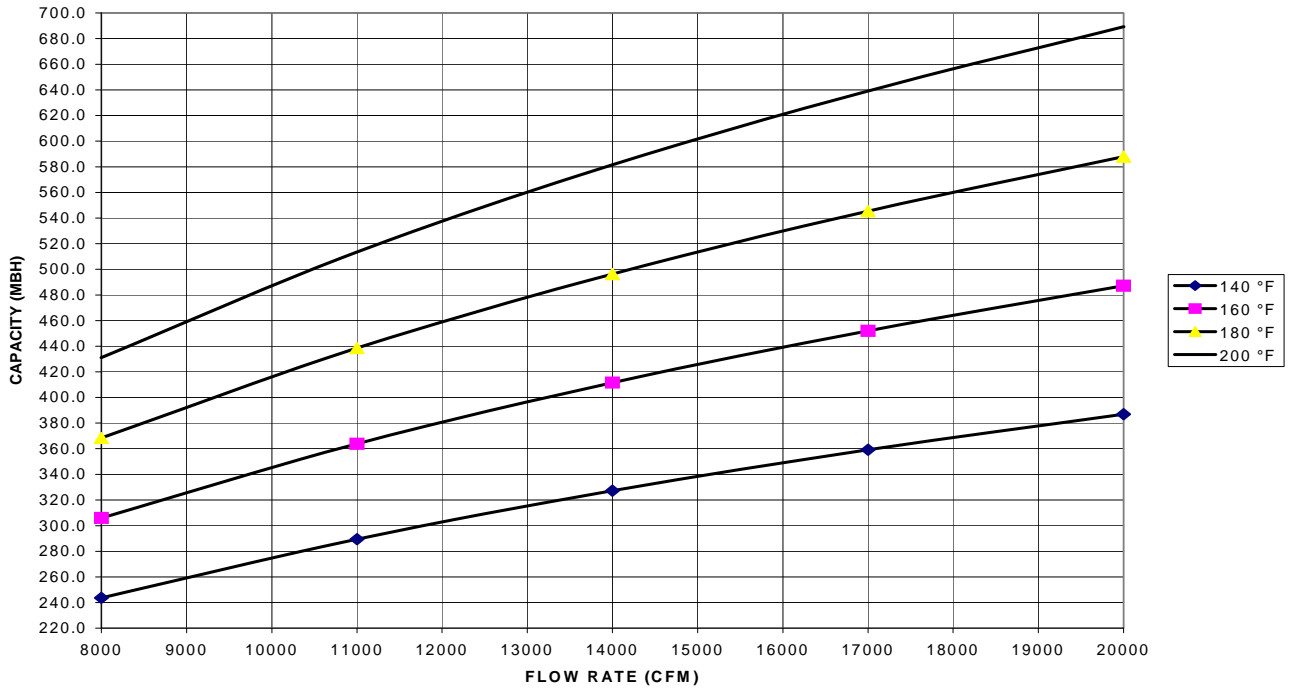

FIGURE 16 - HOT WATER COIL - 40 TON, 2 ROW, AT 60 GPM

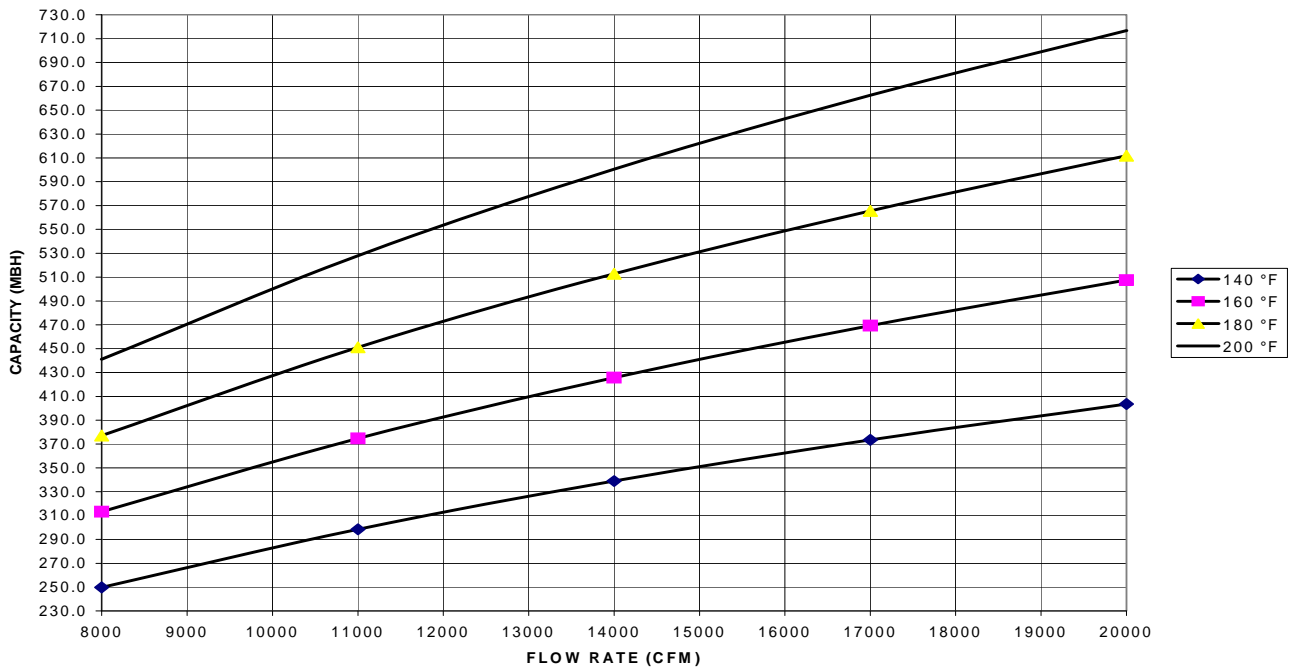

FIGURE 17 - HOT WATER COIL - 40 TON, 2 ROW, AT 80 GPM



## STEAM HEATING

The YORK Millennium units (25, 30, and 40 ton sizes) can be manufactured with a steam heat coil (Bottom Supply only). YORK's one row steam coil is installed in the heating section just downstream of the supply air fan and just above the supply air opening in the bottom of the unit.

The steam control valve will not be provided. The installer will need to field supply a steam control valve. Connect the steam piping and valve power wiring at the job site for the steam heat section to be operational.

There are no provisions in the coil or control sequence to prevent freezing of condensate. The control valve, piping and field installed wiring connections are particularly vulnerable because they are installed in the vestibule outside of the conditioned air stream.

All piping, control valves, and wiring that is field installed must conform to all local and national codes

Condensate can freeze on the control valve and piping if they are not properly insulated.

### PHYSICAL DATA STEAM COIL - 1 ROW

Coil Casing . . . . . Galvanized Steel  
 Coil Construction . . . . . Al Fin / Cu. Tube  
 Rows Deep . . . . . 1  
 Fin Thickness . . . . . .010"  
 Tube Wall . . . . . .035"  
 Tubes / Circuit. . . . . .2  
 Fins Per Inch . . . . . .6  
 Tubes High . . . . . 21"  
 Tube Length . . . . . 65"  
 Face Area . . . . . 9.48 ft.<sup>2</sup>  
 Weight. . . . . 92 lbs.

\*Hot water, steam coil or electric heat not available for front or rear supply.

**TABLE 20: STEAM COIL (1 ROW, 25 & 30 TON)<sup>1</sup>**

CFM	CAPACITY (MBH) AT STEAM PRESSURE (PSI)			
	2	6	10	15
6000	194.1	207.9	219.8	232.6
8000	221.1	236.9	250.4	265.0
10000	243.2	260.5	275.4	291.4
12000	261.9	280.6	296.6	313.9
15000	285.6	306.0	323.5	342.4

<sup>1</sup>. Based on 60°F entering air temperature, 2.00" maximum air pressure drop across the coil.

**TABLE 21: STATIC RESISTANCE STEAM COIL (1 ROW, 25 & 30 TON)**

CFM	6000	8000	10000	12000	15000
AIR PRESSURE DROP	0.11	0.18	0.26	0.36	0.54

**TABLE 22: STEAM COIL (1 ROW, 40 TON)<sup>1</sup>**

CFM	CAPACITY (MBH) AT STEAM PRESSURE (PSI)			
	2	6	10	15
8000	221.1	236.9	250.4	265.0
11000	252.9	271.0	286.4	303.1
14000	278.2	298.0	315.0	333.4
17000	299.4	320.7	339.0	358.8
20000	317.6	340.2	359.6	380.6

<sup>1</sup>. Based on 60°F entering air temperature, 2.00" maximum air pressure drop across the coil.

**TABLE 23: STATIC RESISTANCE STEAM COIL (1 ROW, 40 TON)**

CFM	8000	11000	14000	17000	20000
AIR PRESSURE DROP	0.18	0.31	0.48	0.67	0.88

### PIPING CONNECTIONS

The steam piping must enter the unit through the floor of the heat section compartment. The access doors to the compartment are gasketed to the compartment can be sealed. However, as added protection for condensate leakage into the space, the piping access holes should be sealed with a heat resistant mastic. The following figure illustrates the approximate location of the compartment and piping connections.

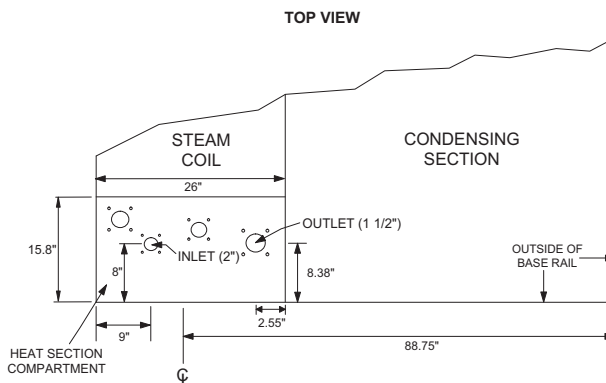

**FIGURE 18 - STEAM PIPING CROSS SECTION**

**WARNING**

DO NOT use tin based solder. Brazing with tin based solder could cause equipment damage or possible injury to OCCUPANTS of the structure that is being conditioned.

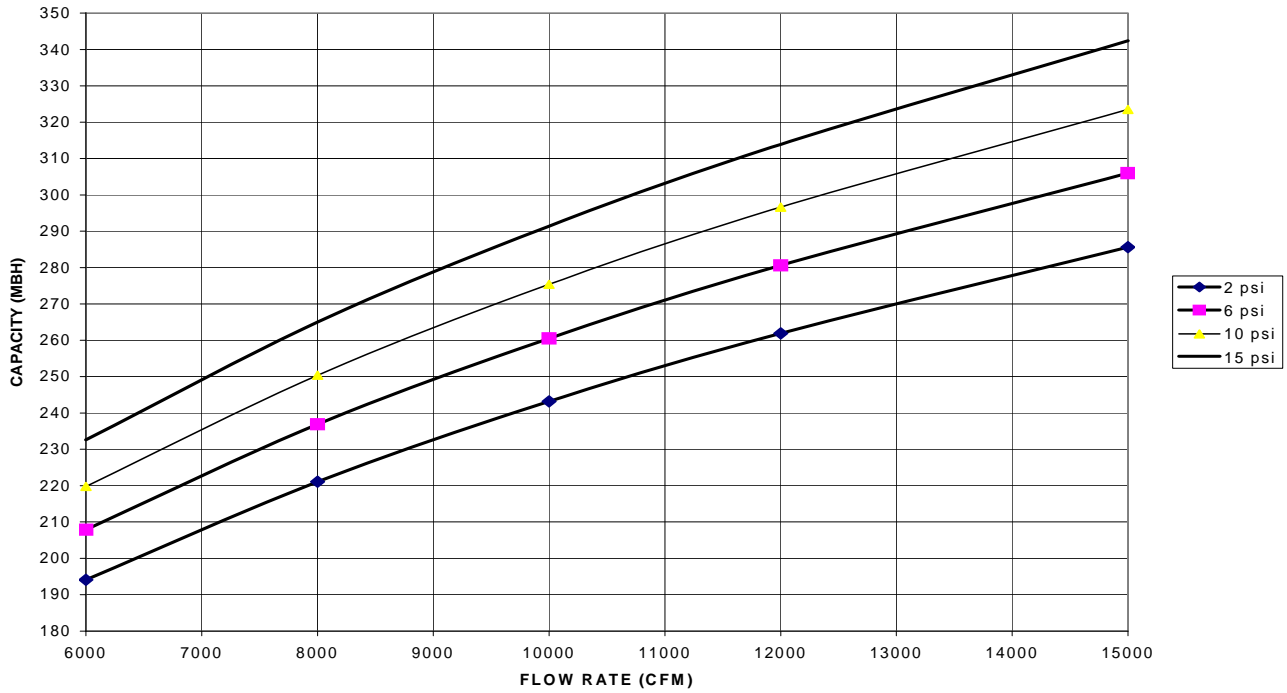

FIGURE 19 - STEAM COIL - 25 & 30 TON, 1 ROW

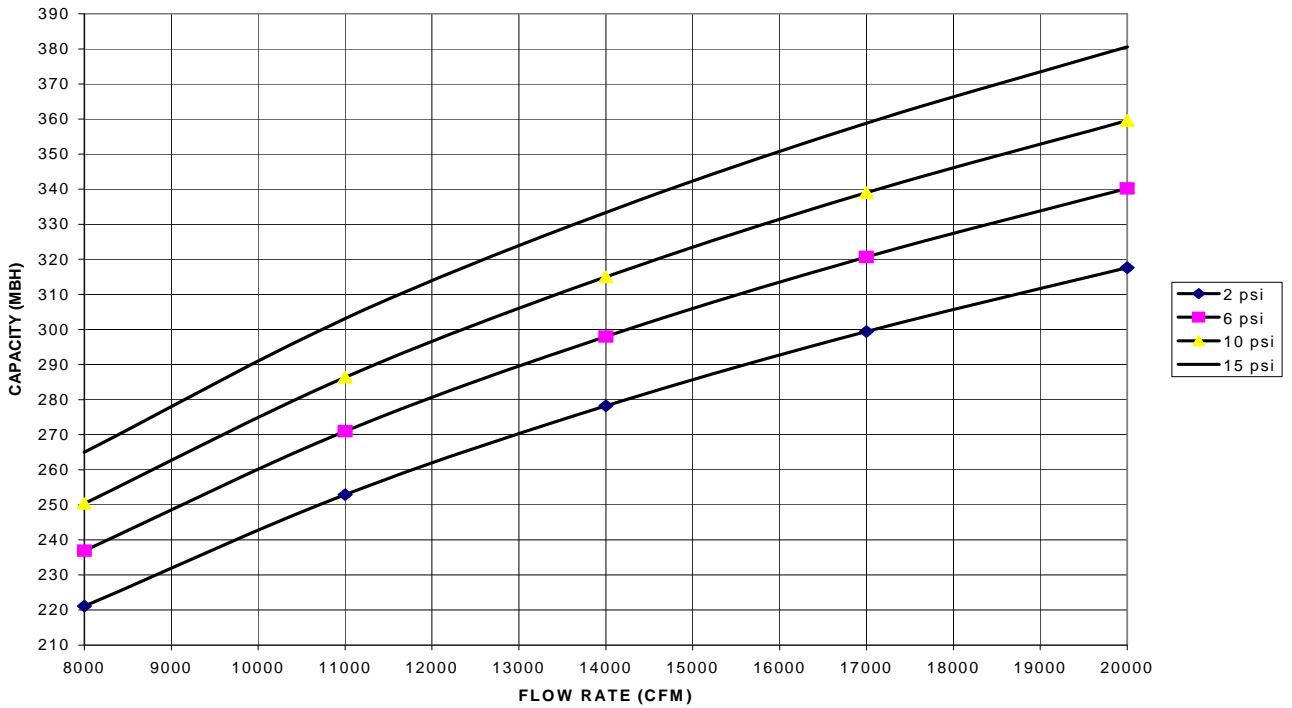

FIGURE 20 - STEAM COIL - 40 TON, 1 ROW

## SUPPLY AIR DRIVE ADJUSTMENT

At unit start-up, the measured CFM may be higher or lower than the specified CFM shown in Figures 22, 23, and 24. To achieve the specified CFM, the speed of the drive may have to be decreased or increased by changing the pitch diameter (PD) of the motor sheave as outlined below: Drives other than those indicated as standard must be purchased and field installed.

$$\frac{\text{Specified CFM}}{\text{Measured CFM}} \bullet \text{PD of Standard Sheave} = \text{PD of New Sheave}$$

### WARNING

Failure to properly adjust the total system air quantity can result in extensive blower damage.

### CAUTION

Before making any blower speed changes review the installation for any installation errors, leaks or undesirable systems effects that can result in loss of air flow.

### WARNING

Failure to properly size the supply blower drives may result in less or more airflow (CFM) than required at design conditions. Please refer to tables 26, 27 and 28 for default factory drive packaged and field drive options. Standard, factory default drive packages are indicated by (Std) within the tables.

### CAUTION

Even small changes in blower speed can result in substantial changes in static pressure and bhp. Bhp or amp draw of the blower motor will increase (see table) by the cube ratio of the blower speed. Static pressure will increase by the square ratio of the blower speed. Tables 26, 27 and 28 are for reference only. All blower speed changes must be made by qualified personnel with strict adherence to the fan laws.

#### Example:

A 30-ton unit was selected to deliver 12,000 CFM with a 20 HP motor and a 856 RPM drive, but the unit is only delivering 11,000 CFM per Figure 24.

Use the equation to determine the required PD for the new motor sheave  $(12,000 \text{ CFM} / 11,000 \text{ CFM}) \times 6.7" = 7.31"$ .

Use the 30 ton table to select a Browning 2B5V74 which will increase the speed of the unit's drive and its supply air CFM to 111.9%. Thus select the 7.5" PD at 112% increase over standard.

$$\text{New drive speed} = 1.119 \times 856 = 957.9 \text{ RPM}$$

$$\text{New supply air} = 1.119 \times 11,000 = 12,309 \text{ CFM}$$

Re-use the existing belts and blower sheave.

New motor BHP =  $(\text{speed increase})^3 \times \text{estimated motor BHP at original start-up with 11,000 CFM and 856 RPM} = (1.119)^3 \times 11 \text{ BHP} = 1.4012 \times 11 \text{ BHP} = 15.41 \text{ BHP}$   
New motor amps =  $(\text{speed increase})^3 \times \text{measured motor amps at original start-up with 11,000 CFM and 856 RPM}$ .

TABLE 24: EXHAUST FAN DRIVE DATA

Model	Blower RPM Range	Motor				Motor Pulley		Blower Pulley		Belts	
		HP	Frame Size	Motor Eff (Std. Motor)	Motor Eff (Hi Eff opt)	Pitch Dia (Inches)	Bore (Inches)	Pitch Dia (Inches)	Bore (Inches)	Designation	Qty
25 Ton	758	5	213T	87.5	89.5	4.9	1-3/8	11.3	2-3/16	BX63	2
	852	7.5	215T	88.5	91.7	5.5	1-3/8	11.3	2-3/16	BX63	2
	976	10	215T	89.5	91	6.3	1-5/8	11.3	2-3/16	BX63	2
30 Ton	852	7.5	213T	84	86.5	5.5	1-3/8	11.3	1-11/16	B65	2
	976	10	215T	86.5	89.5	6.3	1-3/8	11.3	1-11/16	B65	2
	1069	15	254T	85.7	89.5	6.9	1-3/8	11.3	1-11/16	B65	2
40 Ton	852	7.5	184T	84	86.5	5.5	1-3/8	11.3	1-11/16	B65	2
	976	10	215T	86.5	89.5	6.3	1-3/8	11.3	1-11/16	B65	2
	1069	15	254T	85.7	89.5	6.9	1-3/8	11.3	1-11/16	B65	2

TABLE 25: SUPPLY FAN MOTOR AND DRIVE DATA

Model	Blower RPM Range	Motor				Motor Pulley		Blower Pulley		Belts	
		HP	Frame Size	Motor Efficiency (Std. Motor)	Motor Efficiency (Ultra Hi Eff Opt)	Pitch Dia (Inches)	Bore (Inches)	Pitch Dia (Inches)	Bore (Inches)	Designation	Qty
25 Ton	567	7.5	213T	88.5	91.7	4.5	1-3/8	13.9	2-3/16	BX56	2
	692	10	215T	89.5	91	5.5	1-3/8	13.9	2-3/16	BX56	2
	793	15	254T	91	91.7	6.3	1-5/8	13.9	2-3/16	BX56	2
	894	20	256T	91	93	7.1	1-5/8	13.9	2-3/16	BX56	2
30 Ton	617	10	215T	89.5	91	4.9	1-3/8	13.9	2-3/16	BX56	2
	743	15	254T	91	91.7	5.9	1-5/8	13.9	2-3/16	BX56	2
	856	20	256T	91	93	6.7	1-5/8	13.7	2-3/16	5VX610	2
	907	25	284T	91.7	93.6	7.1	1-7/8	13.7	2-3/16	5VX610	2
40 Ton	617	10	215T	89.5	91	4.9	1-3/8	13.9	2-7/16	BX67	2
	652	15	254T	91	91.7	5.1	1-5/8	13.7	2-7/16	5VX710	2
	728	20	256T	91	93	5.7	1-5/8	13.7	2-7/16	5VX710	2
	780	25	284T	91.7	93.6	6.1	1-7/8	13.7	2-7/16	5VX710	2

**TABLE 26: 25 TON DRIVE ADJUSTMENT FOR CONSTANT VOLUME & VAV UNITS CLASS 1 & 2 FC FAN**

7.5 HP MOTOR & 567 RPM DRIVE			10 HP MOTOR & 692 RPM DRIVE			15 HP MOTOR & 793 RPM DRIVE			20 HP MOTOR & 894 RPM DRIVE		
%RPM & CFM	REQ'D PD	BROWNING 2B5V__	%RPM & CFM	REQ'D PD	BROWNING 2B5V__	%RPM & CFM	REQ'D PD	BROWNING 2B5V__	%RPM & CFM	REQ'D PD	BROWNING 2B5V__
-	-	-	82	4.5	42	84	5.3	50	86	6.1	58
-	-	-	86	4.7	44	87	5.5	52	89	6.3	60
100	(Std.) 4.5 <sup>1</sup>	42	89	4.9	46	90	5.7	54	91	6.5	62
104	4.7	44	93	5.1	48	94	5.9	56	94	6.7	64
109	4.9	46	96	5.3	50	97	6.1	58	97	6.9	66
113	5.1	48	100	(Std.) 5.5 <sup>1</sup>	52	100	(Std.) 6.3 <sup>1</sup>	60	100	(Std.) 7.1 <sup>1</sup>	68
118	5.3	50	104	5.7	54	103	6.5	62	103	7.3	70
122	5.5	52	107	5.9	56	106	6.7	64	108	7.7	74
126	5.7	54	111	6.1	58	110	6.9	66	117	8.3	80
-	-	-	115	6.3	60	113	7.1	68	125	8.9	86
-	-	-	118	6.5	62	116	7.3	70	-	-	-
-	-	-	122	6.7	64	122	7.7	74	-	-	-

<sup>1</sup>. (Std), Standard Factory Supplied Drive. All other drive combinations must be purchased and field installed.

**TABLE 27: 30 TON DRIVE ADJUSTMENT FOR CONSTANT VOLUME & VAV UNITS CLASS 1 & 2 FC FAN**

10 HP MOTOR & 617 RPM DRIVE			15 HP MOTOR & 743 RPM DRIVE			20 HP MOTOR & 856 RPM DRIVE			25 HP MOTOR & 907 RPM DRIVE		
%RPM & CFM	REQ'D PD	BROWNING 2B5V__	%RPM & CFM	REQ'D PD	BROWNING 2B5V__	%RPM & CFM	REQ'D PD	BROWNING 2B5V__	%RPM & CFM	REQ'D PD	BROWNING 2B5V__
91.8	4.5	42	86.4	5.1	48	82.1	5.5	54	86.3	6.1	60
95.9	4.7	44	89.8	5.3	50	85.1	5.7	56	89.0	6.3	62
100.0	(Std.) 4.9 <sup>1</sup>	46	93.2	5.5	52	88.1	5.9	58	91.8	6.5	64
104.1	5.1	48	96.6	5.7	54	91.0	6.1	60	94.5	6.7	66
108.2	5.3	50	100.0	(Std.) 5.9 <sup>1</sup>	56	94.0	6.3	62	97.3	6.9	68
112.2	5.5	52	103.4	6.1	58	97.0	6.5	64	100.0	(Std.) 7.1 <sup>1</sup>	70
116.3	5.7	54	106.8	6.3	60	100.0	(Std.) 6.7 <sup>1</sup>	66	105.5	7.5	74
120.4	5.9	56	110.2	6.5	62	103.0	6.9	68	113.7	8.1	80
124.5	6.1	58	113.6	6.7	64	106.0	7.1	70	121.9	8.7	86
-	-	-	116.9	6.9	66	112.0	7.5	74	-	-	-
-	-	-	120.3	7.1	68	120.9	8.1	80	-	-	-
-	-	-	123.7	7.3	70	129.9	8.7	86	-	-	-

<sup>1</sup>. (Std), Standard Factory Supplied Drive. All other drive combinations must be purchased and field installed.

**TABLE 28: 40 TON DRIVE ADJUSTMENT FOR CONSTANT VOLUME & VAV UNITS CLASS 1 & 2 FC FAN**

10 HP MOTOR & 617 RPM DRIVE			15 HP MOTOR & 652 RPM DRIVE			20 HP MOTOR & 728 RPM DRIVE			25 HP MOTOR & 780 RPM DRIVE		
%RPM & CFM	REQ'D PD	BROWNING 2B5V__	%RPM & CFM	REQ'D PD	BROWNING 2B5V__	%RPM & CFM	REQ'D PD	BROWNING 2B5V__	%RPM & CFM	REQ'D PD	BROWNING 2B5V__
91.8	4.5	42	88.2	4.5	44	82.5	4.7	46	83.7	5.1	50
95.9	4.7	44	92.1	4.7	46	86.0	4.9	48	86.9	5.3	52
100.0	(Std.) 4.9 <sup>1</sup>	46	96.0	4.9	48	89.5	5.1	50	90.2	5.5	54
104.1	5.1	48	100.0	(Std.) 5.1 <sup>1</sup>	50	93.0	5.3	52	93.4	5.7	56
108.2	5.3	50	103.9	5.3	52	96.5	5.5	54	96.7	5.9	58
112.2	5.5	52	107.8	5.5	54	100.0	(Std.) 5.7 <sup>1</sup>	56	100.0	(Std.) 6.1 <sup>1</sup>	60
116.3	5.7	54	111.7	5.7	56	103.5	5.9	58	103.3	6.3	62
-	-	-	115.6	5.9	58	107.0	6.1	60	106.6	6.5	64
-	-	-	119.5	6.1	60	110.5	6.3	62	109.8	6.7	66
-	-	-	123.4	6.3	62	114.0	6.5	64	113.1	6.9	68
-	-	-	127.4	6.5	64	117.5	6.7	66	116.4	7.1	70
-	-	-	-	-	66	121.1	6.9	68	119.7	7.5	74

<sup>1</sup>. (Std), Standard Factory Supplied Drive. All other drive combinations must be purchased and field installed.

**TABLE 29: 25 TON DRIVE ADJUSTMENT FOR INTELLISPEED (DISCRETE FAN CONTROL)**

Drive, Fan	7.5 HP MOTOR					10 HP MOTOR					15 HP MOTOR					20 HP MOTOR				
	RPM Drive	Blower Sheave 2B5V <sup>1</sup>	Req'd PD	Motor Sheave 2B5V <sup>1</sup>	Req'd PD	RPM Drive	Blower Sheave 2B5V <sup>1</sup>	Req'd PD	Motor Sheave 2B5V <sup>1</sup>	Req'd PD	RPM Drive	Blower Sheave 2B5V <sup>1</sup>	Req'd PD	Motor Sheave 2B5V <sup>1</sup>	Req'd PD	RPM Drive	Blower Sheave 2B5V <sup>1</sup>	Req'd PD	Motor Sheave 2B5V <sup>1</sup>	Req'd PD
FC CL1	555	136	13.6	42	4.2	555	136	13.6	42	4.2	538	154	15.4	46	4.6	538	154	15.4	46	4.6
FC CL2	555	136	13.6	42	4.2	555	136	13.6	42	4.2	538	154	15.4	46	4.6	538	154	15.4	46	4.6
AF	1187	94	9.4	62	6.2	1187	94	9.4	62	6.2	1187	94	9.4	62	6.2	1187	94	9.4	62	6.2

<sup>1</sup>. All blowers and sheaves are Browning.

**TABLE 30: 30 TON DRIVE ADJUSTMENT FOR INTELLISPEED (DISCRETE FAN CONTROL)**

Drive, Fan	10 HP MOTOR					15 HP MOTOR					20 HP MOTOR					25 HP MOTOR				
	RPM Drive	Blower Sheave 2B5V <sup>1</sup>	Req'd PD	Motor Sheave <sup>1</sup>	Req'd PD	RPM Drive	Blower Sheave 2B5V <sup>1</sup>	Req'd PD	Motor Sheave <sup>1</sup>	Req'd PD	RPM Drive	Blower Sheave 2B5V <sup>1</sup>	Req'd PD	Motor Sheave <sup>1</sup>	Req'd PD	RPM Drive	Blower Sheave 2B5V <sup>1</sup>	Req'd PD	Motor Sheave 2B5V <sup>1</sup>	Req'd PD
FC CL1	502	136	13.6	2TB38	3.8	502	136	13.6	2TB38	3.8	No option					No option				
FC CL2	502	136	13.6	2TB38	3.8	502	136	13.6	2TB38	3.8	502	136	13.6	2TB38	3.8	538	154	15.4	46	4.6
AF	1240	90	9.0	2B5V62	6.2	1240	90	9.0	2B5V62	6.2	1240	90	9.0	2B5V62	6.2	1240	94	9.0	62	6.2

<sup>1</sup>. All blowers and sheaves are Browning.

**TABLE 31: 40 TON DRIVE ADJUSTMENT FOR INTELLISPEED (DISCRETE FAN CONTROL)**

Drive, Fan	10 HP MOTOR					15 HP MOTOR					20 HP MOTOR					25 HP MOTOR				
	RPM Drive	Blower Sheave 2B5V <sup>1</sup>	Req'd PD	Motor Sheave <sup>1</sup>	Req'd PD	RPM Drive	Blower Sheave 2B5V <sup>1</sup>	Req'd PD	Motor Sheave <sup>1</sup>	Req'd PD	RPM Drive	Blower Sheave 2B5V <sup>1</sup>	Req'd PD	Motor Sheave <sup>1</sup>	Req'd PD	RPM Drive	Blower Sheave 2B5V <sup>1</sup>	Req'd PD	Motor Sheave 2B5V <sup>1</sup>	Req'd PD
FC CL1	502	136	13.6	2TB38	3.8	502	136	13.6	2TB38	3.8	502	136	13.6	2TB38	3.8	No option				
FC CL2	502	136	13.6	2TB38	3.8	502	136	13.6	2TB38	3.8	502	136	13.6	2TB38	3.8	538	154	15.4	46	4.6
AF	1187	94	9.4	2B5V62	6.2	1187	94	9.4	2B5V62	6.2	1187	94	9.4	2B5V62	6.2	1187	94	9.4	62	6.2

<sup>1</sup>. All blowers and sheaves are Browning.

**TABLE 32: DRIVE ADJUSTMENT FOR POWER EXHAUST - 25 TON**

5 HP Motor & 758 RPM Drive			7.5 HP Motor & 852 RPM Drive			10 HP Motor & 976 RPM Drive		
%RPM & CFM	Req'd PD	Browning 2b5v__	%RPM & CFM	Req'd PD	Browning 2b5v__	%RPM & CFM	Req'd PD	Browning 2b5v__
100	4.9 (Std.) <sup>1</sup>	46	92	5.1	48	93	5.9	56
104	5.1	48	96	5.3	50	97	6.1	58
109	5.3	50	100	5.5 (Std.) <sup>1</sup>	52	100	6.3 (Std.) <sup>1</sup>	60
113	5.5	52	104	5.7	54	103	6.5	62
117	5.7	54	108	5.9	56	107	6.7	64
122	5.9	56	112	6.1	58	110	6.9	66

<sup>1</sup>. (Std), Standard Factory Supplied Drive. All other drive combinations must be purchased and field installed.

**TABLE 33: DRIVE ADJUSTMENT FOR POWER EXHAUST - 30 & 40 TON**

7.5 HP MOTOR & 852 RPM DRIVE			10 HP MOTOR & 976 RPM DRIVE			15 HP MOTOR & 1069 RPM DRIVE		
% RPM & CFM	REQ'D PD (IN)	BROWNING 2B5V__	% RPM & CFM	REQ'D PD (IN)	BROWNING 2B5V__	% RPM & CFM	REQ'D PD (IN)	BROWNING 2B5V__
96.4	5.3	52	93.7	5.9	58	94.2	6.5	64
100.0	(Std.) 5.5 <sup>1</sup>	54	96.8	6.1	60	97.1	6.7	66
103.6	5.7	56	100.0	(Std.) 6.3 <sup>1</sup>	62	100.0	(Std.) 6.9 <sup>1</sup>	68
107.3	5.9	58	103.2	6.5	64	102.9	7.1	70
110.9	6.1	60	106.3	6.7	66	108.7	7.5	74
114.5	6.3	62	109.5	6.9	68	117.4	8.1	80

<sup>1</sup>. (Std), Standard Factory Supplied Drive. All other drive combinations must be purchased and field installed.

**TABLE 34: COOLING PERFORMANCE - 25 TON R-410A**

AIR ON EVAPORATOR COIL		TEMPERATURE OF AIR ON CONDENSER COIL																			
CFM	WB (°F)	TOTAL CAP. <sup>1</sup> (MBH)	TOTAL <sup>2</sup> INPUT (kW)	SENSIBLE CAPACITY (MBH)* RETURN DRY BULB (°F)								TOTAL CAP. <sup>1</sup> (MBH)	TOTAL <sup>2</sup> INPUT (kW)	SENSIBLE CAPACITY (MBH)* RETURN DRY BULB (°F)							
				86	83	80	77	74	71	68	86			83	80	77	74	71	68		
		75°F								85°F											
7500	72	365.8	21.0	202.1	183.9	165.7	147.5	129.3	-	-	352.2	23.2	192.9	174.9	156.9	138.9	120.9	-	-		
	67	342.4	20.5	248.8	230.6	212.4	194.2	176.1	157.9	139.7	325.5	22.9	239.4	221.5	203.5	185.5	167.5	149.5	131.5		
	62	311.7	20.4	302.2	284.0	265.8	247.6	229.4	211.2	193.0	299.6	22.4	286.0	268.0	250.0	232.0	214.0	196.0	178.0		
	57	300.0	19.7	300.0	299.5	281.3	263.1	244.9	226.7	208.6	289.8	22.0	289.8	284.4	266.5	248.5	230.5	212.5	194.5		
8750	72	376.3	21.2	214.5	193.8	173.1	152.4	131.7	-	-	357.7	23.5	205.1	184.6	164.2	143.7	123.2	-	-		
	67	352.0	20.7	263.3	242.6	221.9	201.2	180.5	159.8	139.1	330.6	23.2	253.8	233.3	212.8	192.4	171.9	151.5	131.0		
	62	320.6	20.6	315.9	298.4	277.7	257.0	236.3	215.6	194.9	304.3	22.6	297.5	282.0	261.6	241.1	220.6	200.2	179.7		
	57	308.6	19.9	308.6	308.4	293.9	273.2	252.5	231.8	211.1	294.3	22.2	294.3	291.6	278.8	258.3	237.8	217.4	196.9		
10000	72	386.7	21.4	226.9	203.7	180.5	157.3	134.1	-	-	363.2	23.7	217.3	194.3	171.4	148.5	125.6	-	-		
	67	361.7	20.9	277.8	254.6	231.4	208.2	185.0	161.8	138.6	335.7	23.4	268.1	245.2	222.2	199.3	176.4	153.4	130.5		
	62	329.5	20.8	329.5	312.8	289.6	266.4	243.2	220.0	196.8	309.0	22.9	309.0	296.0	273.1	250.2	227.3	204.3	181.4		
	57	317.2	20.1	317.2	317.2	306.4	283.2	260.0	236.8	213.6	298.8	22.5	298.8	298.8	291.1	268.1	245.2	222.3	199.3		
11250	72	400.1	21.5	248.4	223.6	198.7	173.9	149.1	-	-	377.0	23.7	237.8	213.3	188.8	164.3	139.8	-	-		
	67	374.2	21.0	304.4	279.6	254.8	229.9	205.1	180.3	155.5	348.5	23.4	293.8	269.3	244.8	220.3	195.8	171.3	146.8		
	62	340.9	20.9	340.9	332.5	318.8	294.0	269.2	244.4	219.5	320.7	22.9	320.7	314.2	300.8	276.3	251.8	227.3	202.8		
	57	328.2	20.2	328.2	328.2	322.8	298.0	273.1	248.3	223.5	310.2	22.5	310.2	310.2	306.3	281.8	257.3	232.8	208.3		
12500	72	413.5	21.6	269.8	243.4	217.0	190.5	164.1	-	-	390.8	23.7	258.3	232.2	206.2	180.1	154.0	-	-		
	67	386.8	21.1	331.0	304.6	278.1	251.7	225.3	198.8	172.4	361.2	23.4	319.4	293.4	267.3	241.2	215.2	189.1	163.0		
	62	352.3	21.0	352.3	352.3	348.1	321.6	295.2	268.8	242.3	332.4	22.8	332.4	332.4	328.5	302.4	276.4	250.3	224.2		
	57	339.1	20.3	339.1	339.1	339.1	312.7	286.2	259.8	233.4	321.5	22.5	321.5	321.5	321.5	295.5	269.4	243.3	217.3		
		95°F								105°F											
7500	72	338.5	25.4	183.8	166.0	148.2	130.3	112.5	-	-	310.7	28.6	171.7	154.3	136.8	119.3	101.9	-	-		
	67	308.7	25.4	230.1	212.3	194.5	176.7	158.9	141.1	123.2	286.0	28.3	219.1	201.6	184.1	166.7	149.2	131.7	114.3		
	62	287.4	24.4	269.9	252.1	234.2	216.4	198.6	180.8	163.0	266.3	27.5	257.5	241.5	224.0	206.6	189.1	171.6	154.2		
	57	279.5	24.3	279.5	269.4	251.6	233.8	216.0	198.2	180.4	264.1	27.5	264.1	252.8	235.3	217.8	200.4	182.9	165.4		
8750	72	339.0	25.7	195.7	175.5	155.2	135.0	114.8	-	-	310.9	28.7	184.1	164.1	144.1	124.0	104.0	-	-		
	67	309.2	25.7	244.2	224.0	203.8	183.5	163.3	143.1	122.9	286.1	28.5	234.0	214.0	193.9	173.9	153.9	133.8	113.8		
	62	287.9	24.7	279.1	265.7	245.5	225.2	205.0	184.8	164.5	266.4	27.7	262.0	251.7	236.0	215.9	195.9	175.9	155.8		
	57	280.0	24.6	280.0	274.9	263.6	243.4	223.2	202.9	182.7	264.2	27.6	264.2	258.5	247.8	227.8	207.7	187.7	167.7		
10000	72	339.6	26.1	207.7	185.0	162.3	139.7	117.0	-	-	311.0	28.9	196.5	173.9	151.3	128.7	106.1	-	-		
	67	309.7	26.0	258.4	235.7	213.1	190.4	167.8	145.1	122.5	286.2	28.6	248.9	226.3	203.8	181.2	158.6	136.0	113.4		
	62	288.4	25.0	288.4	279.3	256.7	234.0	211.3	188.7	166.0	266.5	27.8	266.5	261.9	247.9	225.3	202.7	180.1	157.5		
	57	280.4	24.9	280.4	280.4	275.7	253.0	230.4	207.7	185.0	264.3	27.8	264.3	264.3	260.3	237.7	215.1	192.5	169.9		
11250	72	353.9	25.9	227.2	203.0	178.9	154.7	130.5	-	-	324.0	28.9	214.9	190.8	166.8	142.7	118.6	-	-		
	67	322.7	25.8	283.1	259.0	234.8	210.6	186.4	162.2	138.1	298.2	28.7	272.6	248.6	224.5	200.5	176.4	152.3	128.3		
	62	300.5	24.8	300.5	295.9	282.8	258.6	234.4	210.3	186.1	277.6	27.9	277.6	275.4	267.4	243.4	219.3	195.3	171.2		
	57	292.2	24.8	292.2	292.2	289.8	265.6	241.5	217.3	193.1	275.4	27.8	275.4	275.4	273.4	249.3	225.3	201.2	177.2		
12500	72	368.1	25.8	246.8	221.1	195.4	169.7	144.0	-	-	337.1	29.0	233.2	207.7	182.2	156.7	131.1	-	-		
	67	335.7	25.7	307.9	282.2	256.5	230.8	205.1	179.4	153.7	310.2	28.7	296.3	270.8	245.3	219.7	194.2	168.7	143.2		
	62	312.6	24.7	312.6	312.6	308.9	283.2	257.5	231.8	206.1	288.8	27.9	288.8	288.8	287.0	261.5	235.9	210.4	184.9		
	57	304.0	24.6	304.0	304.0	278.3	252.6	226.9	201.2	177.2	286.5	27.9	286.5	286.5	261.0	235.5	209.9	184.4			
		115°F								125°F											
7500	72	283.0	31.7	159.7	142.6	125.5	108.3	91.2	-	-	255.3	34.9	147.7	130.9	114.1	97.3	80.5	-	-		
	67	263.3	31.3	208.0	190.9	173.8	156.7	139.5	122.4	105.3	240.6	34.2	197.0	180.2	163.5	146.7	129.9	113.1	96.3		
	62	245.1	30.7	245.1	230.9	213.8	196.7	179.5	162.4	145.3	223.9	33.8	223.9	220.4	203.6	186.8	170.0	153.2	136.4		
	57	248.8	30.6	248.8	236.1	219.0	201.9	184.7	167.6	150.5	233.4	33.8	233.4	219.5	202.7	185.9	169.1	152.3	135.6		
8750	72	282.7	31.8	172.6	152.7	132.9	113.1	93.2	-	-	254.5	34.8	161.0	141.3	121.7	102.1	82.5	-	-		
	67	263.0	31.3	223.8	203.9	184.1	164.3	144.4	124.6	104.8	239.9	34.1	213.5	193.9	174.3	154.6	135.0	115.4	95.7		
	62	244.8	30.7	244.8	237.7	226.5	206.6	186.8	167.0	147.2	223.3	33.7	223.3	223.3	217.0	197.4	177.7	158.1	138.5		
	57	248.5	30.7	248.5	242.2	232.0	212.2	192.3	172.5	152.7	232.8	33.7	232.8	225.8	216.2	196.5	176.9	157.3	137.6		
10000	72	282.4	31.8	185.4	162.9	140.3	117.8	95.3	-	-	253.7	34.6	174.3	151.8	129.3	106.9	84.4	-	-		
	67	262.7	31.3	239.5	217.0	194.4	171.9	149.3	126.8	104.3	239.2	34.0	230.0	207.6	185.1	162.6	140.1	117.6	95.2		
	62	244.5	30.7	244.5	244.5	239.2	216.6	194.1	171.5	149.0	222.6	33.6	222.6	222.6	207.9	185.5	163.0	140.5			
	57	248.2	30.7	248.2	248.2	245.0	222.4	199.9	177.4	154.8	232.1	33.5	232.1	232.1	229.6	207.2	184.7	162.2	139.7		
11250	72	294.2	32.0	202.5	178.6	154.6	130.7	106.8	-	-	264.4	35.0	190.2	166.4	142.5	118.7	94.9	-	-		
	67	273.7	31.5	262.1	238.2	214.2	190.3	166.4	142.4	118.5	249.2	34.3	249.2	227.8	204.0	180.2	156.3	132.5	108.7		
	62	254.8	30.9	254.8	254.8	252.1	228.2	204.2	180.3	156.4	232.0	33.9	232.0	232.0	232.0	212.9	189.1	165.3	141.5		
	57	258.6	30.9	258.6	258.6	257.0	233.1	209.1	185.2	161.3	241.8	33.9	241.8	241.8	240.6	216.8	193.0	169.1	145.3		
12500	72	306.0	32.2	219.6	194.3	169.0															



**TABLE 35: COOLING PERFORMANCE - 30 TON R-410A**

AIR ON EVAPORATOR COIL		TEMPERATURE OF AIR ON CONDENSER COIL															
CFM	WB (°F)	TOTAL CAPACITY <sup>1</sup> (MBH)	TOTAL INPUT <sup>2</sup> (KW)	SENSIBLE CAPACITY (MBH)						TOTAL CAPACITY <sup>1</sup> (MBH)	TOTAL INPUT <sup>2</sup> (KW)	SENSIBLE CAPACITY (MBH)					
				RETURN DRY BULB (°F)								RETURN DRY BULB (°F)					
				90	85	80	75	70	65			90	85	80	75	70	65
				75°F						85°F							
7500	77	493.5	25.5	379.5	301.6	223.8	-	-	-	423.8	27.1	267.8	218.8	169.8	-	-	-
	72	442.7	24.8	357.4	295.9	234.4	172.9	111.4	49.9	391.2	26.6	296.1	249.8	203.5	157.1	110.8	64.5
	67	391.9	24.2	335.3	290.1	245.0	211.0	170.9	133.8	358.6	26.1	324.4	280.8	237.2	198.7	157.1	117.1
	62	392.7	23.1	392.7	349.0	263.7	269.9	230.4	213.7	358.8	25.1	358.8	330.9	277.0	251.7	203.5	166.7
9000	77	488.8	25.5	378.2	293.9	209.5	-	-	-	429.8	27.2	290.2	227.9	165.5	-	-	-
	72	448.2	25.0	370.3	302.5	234.77	167.0	99.2	31.5	402.8	26.8	319.3	263.7	208.1	152.5	96.9	41.3
	67	407.7	24.4	362.4	311.2	260.0	216.1	167.4	121.1	375.7	26.3	348.4	299.6	250.7	203.9	154.6	106.6
	62	408.2	23.5	408.2	365.0	285.2	278.7	235.6	210.7	374.1	25.4	374.1	347.6	293.4	262.0	212.3	171.8
	57	408.7	22.5	408.0	359.2	310.5	307.1	303.7	300.4	372.4	24.5	372.4	356.4	336.0	303.0	270.0	237.1
10500	77	484.0	25.6	377.0	286.2	195.3	-	-	-	435.9	27.2	312.6	236.9	161.2	-	-	-
	72	453.7	25.1	383.2	309.2	235.2	161.1	87.1	13.1	414.4	26.9	342.5	277.6	212.8	147.9	83.0	18.2
	67	423.4	24.6	389.5	332.2	275.0	221.3	163.9	108.4	392.9	26.5	372.4	318.3	264.3	209.1	152.1	96.0
	62	423.6	23.8	423.6	381.0	306.8	287.5	240.8	207.8	389.3	25.8	389.3	364.2	309.7	272.3	221.2	176.9
	57	423.8	23.1	423.3	380.9	338.6	328.1	317.6	307.1	388.0	25.0	388.0	373.2	355.1	322.7	290.2	257.8
12000	77	479.3	25.6	375.8	278.5	181.1	-	-	-	442.0	27.3	335.1	246.0	157.0	-	-	-
	72	459.3	25.2	396.2	315.9	235.6	155.3	74.9	-	426.0	27.0	365.7	291.5	217.4	143.3	69.1	-
	67	439.2	24.8	416.6	353.3	290.0	226.5	160.5	95.7	410.0	26.7	396.3	337.1	277.9	214.3	149.6	85.4
	62	439.1	24.2	439.1	397.0	328.3	296.3	246.0	204.8	404.5	26.1	404.5	380.9	326.0	282.6	230.0	182.0
	57	438.9	23.6	438.6	402.6	366.7	349.1	331.5	313.9	403.5	25.5	403.5	390.0	374.2	342.3	310.5	278.6
13500	72	464.8	25.4	409.1	322.6	236.0	149.4	62.8	-	437.6	27.1	388.9	305.5	222.1	138.7	55.3	-
	67	455.0	25.0	443.7	374.4	305.0	231.6	157.0	83.0	427.1	26.9	420.3	355.9	291.4	219.6	147.1	74.9
	62	454.5	24.6	454.5	413.0	349.9	305.1	251.2	201.8	419.8	26.4	419.8	397.6	342.4	292.9	238.9	187.1
	57	454.0	24.2	453.9	424.3	394.8	370.1	345.4	320.7	419.0	26.0	419.0	406.7	393.3	362.0	330.7	299.3
15000	72	470.3	25.5	422.1	329.2	236.36	143.5	50.6	-	449.2	27.3	412.1	319.4	226.7	134.0	41.4	-
	67	470.8	25.3	470.8	395.4	320.0	236.8	153.5	70.3	444.2	27.1	444.2	374.6	305.0	224.8	144.5	64.3
	62	470.0	25.0	470.0	429.0	371.5	313.9	256.4	198.9	435.0	26.8	435.0	414.2	358.7	303.2	247.7	192.2
	57	469.2	24.7	469.2	446.0	422.9	391.1	359.3	327.4	434.6	26.4	434.6	423.5	412.4	381.7	350.9	320.1
				95°F						105°F							
7500	77	354.1	28.8	156.1	135.9	115.8	-	-	-	339.0	31.6	161.1	124.5	87.9	-	161.1	-
	72	339.7	28.4	234.9	203.7	172.5	141.4	110.2	79.1	325.0	31.1	232.1	192.2	152.3	112.4	72.5	32.6
	67	325.4	28.0	313.6	271.5	229.3	186.4	143.4	100.5	310.9	30.7	303.0	259.9	216.7	173.9	131.1	88.3
	62	325.0	27.1	325.0	312.8	290.4	233.5	176.6	119.7	307.5	29.9	307.5	298.2	283.3	236.5	189.7	142.9
9000	77	370.9	28.8	202.2	161.8	121.4	-	-	-	353.7	31.5	203.3	151.0	98.6	-	-	-
	72	357.4	28.5	268.3	224.9	181.45	138.0	94.6	51.2	341.0	31.2	262.7	212.8	162.8	112.8	62.9	12.9
	67	343.8	28.2	334.4	287.9	241.5	191.7	141.8	92.0	328.4	30.9	322.1	274.6	227.0	178.0	129.1	80.1
	62	340.0	27.4	340.0	330.1	301.5	245.3	189.1	132.9	323.3	30.2	323.3	313.7	291.2	243.3	195.3	147.3
	57	336.2	26.5	336.2	336.2	336.2	298.9	236.3	173.7	318.3	29.4	318.3	318.3	318.3	303.6	251.7	199.9
10500	77	387.8	28.9	248.2	187.7	127.1	-	-	-	368.4	31.5	245.6	177.4	109.2	-	-	-
	72	375.0	28.7	301.7	246.0	190.4	134.7	79.0	23.3	357.1	31.3	293.4	233.3	173.3	113.2	53.2	-
	67	362.3	28.4	355.2	304.4	253.6	196.9	140.3	83.6	345.9	31.1	341.2	289.3	237.3	182.2	127.1	71.9
	62	355.0	27.7	355.0	347.5	312.6	257.1	201.6	146.0	339.2	30.4	339.2	329.1	299.1	250.0	200.9	151.8
	57	352.1	26.9	352.1	352.1	352.1	317.2	262.9	208.5	335.4	29.8	335.4	335.4	335.4	314.2	267.4	220.7
12000	77	404.6	28.9	294.3	213.5	132.8	-	-	-	383.1	31.5	287.8	203.8	119.9	-	-	-
	72	392.7	28.8	335.2	267.2	199.3	131.3	63.4	-	373.2	31.4	324.0	253.9	183.8	113.7	43.5	-
	67	380.7	28.6	376.0	320.9	265.7	202.2	138.7	75.2	363.4	31.3	360.3	304.0	247.7	186.4	125.0	63.7
	62	370.0	28.0	370.0	364.8	323.7	268.9	214.1	159.2	355.0	30.7	355.0	344.5	307.0	256.8	206.5	156.3
	57	368.1	27.3	368.1	368.1	368.1	335.6	289.4	243.2	352.5	30.2	352.5	352.5	352.5	324.7	283.2	241.6
13500	72	410.3	28.9	368.6	288.4	208.2	127.9	47.7	-	389.3	31.6	354.7	274.5	194.3	114.1	33.9	-
	67	399.2	28.8	396.8	337.4	277.9	207.5	137.1	66.8	380.9	31.5	379.3	318.7	258.0	190.5	123.0	55.5
	62	385.0	28.3	385.0	382.1	334.9	280.7	226.5	172.4	370.8	31.0	370.8	359.9	314.9	263.5	212.2	160.8
	57	384.0	27.7	384.0	384.0	384.0	353.9	315.9	278.0	369.6	30.5	369.6	369.6	369.6	335.3	298.9	262.4
15000	72	428.0	29.0	402.0	309.6	217.07	124.6	32.1	-	405.3	31.7	385.3	295.0	204.8	114.5	24.2	-
	67	417.6	29.0	417.6	353.8	290.0	212.8	135.6	58.3	398.4	31.6	398.4	333.4	268.3	194.7	121.0	47.3
	62	400.0	28.6	400.0	399.5	346.0	292.5	239.0	185.5	386.7	31.3	386.7	375.3	322.8	270.3	217.8	165.3
	57	400.0	28.2	400.0	400.0	400.0	372.2	342.5	312.7	386.7	30.9	386.7	382.0	377.3	345.9	314.6	283.3

**TABLE 35: COOLING PERFORMANCE - 30 TON R-410A**

AIR ON EVAPORATOR COIL		TEMPERATURE OF AIR ON CONDENSER COIL															
CFM	WB (°F)	TOTAL CAPACITY <sup>1</sup> (MBH)	TOTAL INPUT <sup>2</sup> (kW)	SENSIBLE CAPACITY (MBH)						TOTAL CAPACITY <sup>1</sup> (MBH)	TOTAL INPUT <sup>2</sup> (kW)	SENSIBLE CAPACITY (MBH)					
				RETURN DRY BULB (°F)								RETURN DRY BULB (°F)					
				90	85	80	75	70	65			90	85	80	75	70	65
				115°F						125°F							
7500	77	323.9	34.4	166.1	113.1	60.1	-	-	-	308.8	37.2	171.1	101.7	32.3	-	-	-
	72	310.2	33.8	229.3	180.7	132.1	83.4	34.8	-	295.5	36.5	226.5	169.2	111.8	54.5	-	-
	67	296.4	33.4	292.5	248.2	204.0	161.4	118.8	76.2	281.9	36.0	281.9	236.6	191.3	148.9	106.4	-
	62	290.0	32.7	290.0	283.7	276.3	239.5	202.7	166.0	272.5	35.5	272.5	269.2	269.2	242.5	215.8	189.1
9000	77	336.5	34.3	204.5	140.1	75.7	-	-	-	319.2	37.0	205.7	129.3	52.9	-	-	-
	72	324.7	33.9	257.2	200.6	144.1	87.6	31.1	-	308.4	36.6	251.6	188.5	125.5	62.4	-	-
	67	313.0	33.5	309.8	261.2	212.5	164.4	116.3	68.2	297.5	36.2	297.5	247.8	198.1	150.8	103.5	56.3
	62	306.7	32.9	306.7	297.2	280.9	241.2	201.5	161.8	290.0	35.7	290.0	280.7	270.6	239.2	207.7	176.2
	57	300.4	32.4	300.4	300.4	300.4	300.4	267.1	226.0	282.5	35.3	282.5	282.5	282.5	282.5	282.5	252.1
10500	77	349.0	34.1	242.9	167.1	91.4	-	-	-	329.6	36.8	240.2	156.8	73.5	-	-	-
	72	339.2	34.0	285.0	220.6	156.2	91.8	27.4	-	321.3	36.7	276.7	207.9	139.1	70.4	1.6	-
	67	329.5	33.7	327.2	274.1	221.1	167.5	113.8	60.2	313.1	36.4	313.1	259.0	204.8	152.7	100.6	48.5
	62	323.3	33.2	323.3	310.7	285.6	242.9	200.3	157.6	307.5	36.0	307.5	292.3	272.1	235.9	199.6	163.4
	57	318.6	32.7	318.6	318.6	318.6	311.1	272.0	232.9	301.9	35.5	301.9	301.9	301.9	301.9	276.6	245.2
12000	77	361.5	34.0	281.2	194.1	107.0	-	-	-	340.0	36.5	274.7	184.4	94.1	274.7	-	-
	72	353.7	34.1	312.9	240.6	168.3	96.0	23.7	-	334.2	36.8	301.7	227.3	152.8	78.3	3.9	-
	67	346.1	33.9	344.5	287.1	229.6	170.5	111.4	52.3	328.8	36.5	328.8	270.1	211.5	154.6	97.7	40.8
	62	340.0	33.5	340.0	324.2	290.3	244.7	199.0	153.4	325.0	36.2	325.0	303.8	273.5	232.5	191.5	150.5
	57	336.9	33.0	336.9	336.9	336.9	313.9	276.9	239.9	321.2	35.8	321.2	321.2	321.2	303.1	270.7	238.2
13500	72	368.2	34.2	340.7	260.6	180.4	100.2	20.0	-	347.1	36.8	326.8	246.6	166.5	86.3	6.1	-
	67	362.6	34.1	361.9	300.0	238.1	173.5	108.9	44.3	344.4	36.7	344.4	281.3	218.3	156.5	94.8	33.1
	62	356.7	33.7	356.7	337.6	294.9	246.4	197.8	149.2	342.5	36.4	342.5	315.4	275.0	229.2	183.4	137.7
	57	355.1	33.3	355.1	353.8	351.7	316.8	281.8	246.8	340.6	36.1	340.6	336.1	331.7	298.2	264.7	231.3
15000	72	382.7	34.3	368.6	280.5	192.4	104.4	16.3	-	360.0	36.9	351.9	266.0	180.1	94.3	8.4	-
	67	379.2	34.3	379.2	312.9	246.7	176.6	106.4	36.3	360.0	36.9	360.0	292.5	225.0	158.4	91.9	25.3
	62	373.3	34.0	373.3	351.1	299.6	248.1	196.6	145.1	360.0	36.7	360.0	326.9	276.4	225.9	175.4	124.8
	57	373.3	33.7	373.3	362.9	352.5	319.6	286.7	253.8	360.0	36.4	360.0	343.9	327.8	293.3	258.8	224.3

1. These capacities are gross ratings. For net capacity, deduct the supply air blower motor heat (MBH = 3.415 x kW). Refer to the appropriate Blower Performance Table for the kW of the supply air blower motor.  
 2. These ratings include the condenser fan motors and the compressor motors but not the supply air blower motor.

**TABLE 36: COOLING PERFORMANCE - 40 TON R-410A**

AIR ON EVAPORATOR COIL		TEMPERATURE OF AIR ON CONDENSER COIL															
CFM	WB (°F)	TOTAL CAPACITY <sup>1</sup> (MBH)	TOTAL INPUT <sup>2</sup> (kW)	SENSIBLE CAPACITY (MBH)						TOTAL CAPACITY <sup>1</sup> (MBH)	TOTAL INPUT <sup>2</sup> (kW)	SENSIBLE CAPACITY (MBH)					
				RETURN DRY BULB (°F)								RETURN DRY BULB (°F)					
				90	85	80	75	70	65			90	85	80	75	70	65
		75°F						85°F									
10000	77	607.7	29.3	318.2	254.1	190.0	-	-	-	580.1	31.6	304.5	247.4	190.3	-	-	-
	72	539.1	28.5	365.4	308.3	251.3	194.2	137.2	80.1	516.7	30.9	357.3	300.7	244.0	187.3	130.6	73.9
	67	470.6	27.8	412.6	362.6	312.5	243.1	194.4	135.4	453.4	30.1	410.2	353.9	297.6	236.7	186.1	130.3
	62	457.9	27.2	457.9	400.0	350.6	301.1	251.7	178.1	448.5	29.6	441.4	394.7	343.6	292.6	241.5	178.4
12000	77	615.3	32.1	352.9	270.6	188.2	-	-	-	584.5	34.4	342.1	263.8	185.5	-	-	-
	72	554.0	31.4	399.6	331.7	263.8	195.8	127.9	59.9	528.5	33.7	390.0	322.5	255.0	187.4	119.9	52.4
	67	492.7	30.7	446.3	392.8	339.3	260.8	199.0	128.8	472.5	33.1	438.0	381.2	324.4	252.6	189.1	121.4
	62	482.3	30.1	482.3	429.2	414.8	323.1	270.1	197.7	466.8	32.5	461.2	419.7	385.2	312.1	258.3	194.8
	57	471.9	29.5	471.9	471.9	471.9	406.5	341.2	275.9	461.1	31.9	461.1	449.0	436.8	382.1	327.4	272.7
14000	77	622.9	34.8	387.7	287.1	186.4	-	-	-	588.9	37.1	379.7	280.2	180.7	-	-	-
	72	568.9	34.2	433.9	355.1	276.2	197.4	118.6	39.8	540.3	36.6	422.7	344.3	265.9	187.5	109.2	30.8
	67	514.9	33.6	480.1	423.0	366.0	278.6	203.6	122.3	491.7	36.0	465.7	408.4	351.1	268.5	192.1	112.5
	62	506.7	33.0	506.7	458.5	430.8	345.2	288.5	217.4	485.1	35.4	480.9	444.8	402.7	331.6	275.0	211.1
	57	498.6	32.4	498.6	490.1	481.7	427.6	373.5	319.4	478.6	34.8	478.6	462.9	447.3	402.6	357.9	313.2
16000	77	630.6	37.5	422.5	303.6	184.7	-	-	-	593.3	39.8	417.3	296.6	176.0	-	-	-
	72	583.8	37.0	468.1	378.4	288.7	199.0	109.3	19.6	552.0	39.4	455.4	366.2	276.9	187.7	98.4	9.2
	67	537.1	36.5	513.8	453.3	392.8	296.3	208.1	115.8	510.8	39.0	493.5	435.7	377.9	284.4	195.1	103.7
	62	531.2	35.9	531.2	487.7	446.8	367.2	307.0	237.1	503.4	38.3	500.6	469.8	420.1	351.1	291.7	227.5
	57	525.3	35.3	525.3	508.4	491.6	448.7	405.8	362.9	496.0	37.7	496.0	476.9	457.7	423.0	388.4	353.7
18000	72	598.7	39.8	502.4	401.8	301.2	200.6	100.0		563.8	42.2	488.1	388.0	287.9	187.8	87.7	
	67	559.3	39.5	547.6	483.5	419.5	314.0	212.7	109.3	530.0	41.9	521.3	463.0	404.6	300.3	198.1	94.8
	62	555.6	38.8	555.6	517.0	462.8	389.3	325.4	256.7	521.7	41.3	520.3	494.9	437.6	370.6	308.4	243.9
	57	552.0	38.2	552.0	526.7	501.4	469.8	438.1	406.5	513.5	40.6	513.5	490.9	468.2	443.5	418.8	394.1
	72	613.6	42.7	536.7	425.2	313.7	202.2	90.7		575.6	45.1	520.8	409.8	298.9	187.9	77.0	
20000	67	581.5	42.4	581.3	513.8	446.2	331.7	217.3	102.8	549.1	44.9	549.1	490.2	431.4	316.2	201.1	85.9
	62	580.1	41.7	580.0	546.2	478.8	411.3	343.8	276.4	540.0	44.2	540.0	520.0	455.0	390.1	325.2	260.2
	57	578.7	41.1	578.7	545.0	511.3	490.9	470.4	450.0	530.9	43.5	530.9	504.8	478.7	464.0	449.3	434.6
	72	598.7	39.8	502.4	401.8	301.2	200.6	100.0		563.8	42.2	488.1	388.0	287.9	187.8	87.7	
		95°F						105°F									
10000	77	552.5	33.9	290.8	240.7	190.7	-	-	-	501.4	37.4	273.0	222.8	172.7	-	-	-
	72	494.3	33.2	349.3	293.0	236.7	180.4	124.1	67.8	457.8	36.4	334.6	279.4	224.2	169.1	113.9	58.7
	67	436.2	32.5	407.8	345.3	282.7	230.2	177.7	125.2	414.3	35.8	396.1	335.9	275.8	220.2	164.6	109.1
	62	439.2	32.0	425.0	389.3	336.7	284.0	231.4	178.7	416.6	35.2	407.3	377.7	323.6	269.5	215.4	161.3
12000	77	553.7	36.7	331.2	257.1	182.9	-	-	-	505.1	39.7	312.1	240.6	169.1	-	-	-
	72	503.0	36.1	380.4	313.3	246.2	179.0	111.9	44.8	467.3	39.2	363.3	297.8	232.3	166.8	101.3	35.8
	67	452.3	35.5	429.6	369.5	309.5	244.3	179.2	114.0	429.5	38.6	414.4	354.9	295.5	230.9	166.4	101.8
	62	451.3	34.9	440.0	410.2	355.6	301.0	246.4	191.8	428.9	38.0	421.3	394.7	340.3	285.8	231.4	177.0
	57	450.4	34.3	450.4	426.1	401.8	357.7	313.7	269.6	428.3	37.4	428.3	406.7	385.0	340.7	296.4	252.1
14000	77	554.8	39.4	371.7	273.4	175.0	-	-	-	508.8	42.0	351.3	258.4	165.5	-	-	-
	72	511.6	38.9	411.5	333.6	255.6	177.7	99.7	21.8	476.8	42.0	392.0	316.2	240.3	164.5	88.7	12.9
	67	468.4	38.4	451.4	393.8	336.2	258.4	180.6	102.8	444.8	41.5	432.6	373.9	315.2	241.6	168.1	94.5
	62	463.5	37.8	455.0	431.1	374.5	318.0	261.4	204.9	441.2	40.9	435.3	411.7	356.9	302.1	247.4	192.6
	57	458.6	37.2	458.6	435.7	412.8	377.6	342.3	307.0	438.0	40.3	438.0	417.9	397.8	362.2	326.7	291.2
16000	77	556.0	42.2	412.1	289.7	167.2	-	-	-	512.5	44.4	390.4	276.2	161.9	-	-	-
	72	520.3	41.8	442.7	353.9	265.1	176.3	87.6		486.2	44.8	420.6	334.5	248.4	162.3	76.2	
	67	484.5	41.4	473.2	418.1	363.0	272.5	182.0	91.5	460.0	44.4	450.9	392.9	334.9	252.3	169.8	87.2
	62	475.7	40.8	470.0	451.9	393.5	335.0	276.5	218.0	453.5	43.7	449.3	428.6	373.5	318.5	263.4	208.3
	57	466.8	40.1	466.8	445.4	423.9	397.4	370.9	344.4	447.8	43.1	447.8	429.1	410.5	383.7	357.0	330.2
18000	72	528.9	44.7	473.8	374.2	274.6	175.0	75.4		495.7	47.5	449.3	352.9	256.5	160.0	63.6	
	67	500.7	44.4	495.0	442.4	389.8	286.6	183.4	80.3	475.3	47.2	469.1	411.9	354.6	263.1	171.5	79.9
	62	487.8	43.7	485.0	472.8	412.4	351.9	291.5	231.0	465.8	46.5	463.3	445.6	390.2	334.8	279.4	223.9
	57	475.0	43.0	475.0	455.0	435.0	417.3	399.5	381.8	457.5	45.9	457.5	440.4	423.2	405.2	387.2	369.2
20000	72	537.5	47.5	504.9	394.5	284.1	173.7	63.3		505.2	50.3	478.0	371.3	264.5	157.8	51.0	
	67	516.8	47.4	516.8	466.7	416.5	300.7	184.9	69.1	490.6	50.1	487.4	430.9	374.3	273.8	173.2	72.6
	62	500.0	46.6	500.0	493.7	431.3	368.9	306.5	244.1	478.1	49.4	477.3	462.6	406.8	351.1	295.3	239.6
	57	483.2	45.9	483.2	464.6	446.1	437.1	428.1	419.2	467.3	48.7	467.3	451.6	436.0	426.7	417.5	408.2

**TABLE 36: COOLING PERFORMANCE - 40 TON R-410A**

AIR ON EVAPORATOR COIL		TEMPERATURE OF AIR ON CONDENSER COIL															
CFM	WB (°F)	TOTAL CAPACITY <sup>1</sup> (MBH)	TOTAL INPUT <sup>2</sup> (kW)	SENSIBLE CAPACITY (MBH)						TOTAL CAPACITY <sup>1</sup> (MBH)	TOTAL INPUT <sup>2</sup> (kW)	SENSIBLE CAPACITY (MBH)					
				RETURN DRY BULB (°F)								RETURN DRY BULB (°F)					
				90	85	80	75	70	65			90	85	80	75	70	65
				115°F						125°F							
10000	77	450.2	40.9	255.2	204.9	154.7				399.1	44.4	237.3	187.1	136.8			
	72	421.3	39.6	319.8	265.8	211.8	157.7	103.7	49.7	384.8	42.8	305.1	252.2	199.3	146.4	93.5	40.6
	67	392.3	39.1	384.5	326.6	268.8	210.2	151.6	92.9	370.4	42.4	370.4	317.3	261.8	200.2	138.5	76.8
	62	394.0	38.5	389.7	366.1	310.5	255.0	199.4	143.9	371.4	41.7	371.4	354.4	297.4	240.4	183.5	126.5
12000	77	456.5	42.8	293.0	224.2	155.3	-	-	-	407.9	45.8	273.9	207.7	141.6			
	72	431.6	42.3	346.1	282.3	218.4	154.6	90.7	26.9	395.9	45.4	328.9	266.7	204.5	142.3	80.1	17.9
	67	406.7	41.8	399.2	340.3	281.5	217.5	153.5	89.6	384.0	45.0	384.0	325.7	267.5	204.1	140.7	77.4
	62	406.4	41.2	402.7	379.1	324.9	270.6	216.4	162.1	384.0	44.4	384.0	363.6	309.5	255.4	201.4	147.3
	57	406.2	40.6	406.2	387.2	368.3	323.8	279.2	234.7	384.0	43.7	384.0	367.8	351.6	306.8	262.0	217.2
14000	77	462.7	44.7	330.9	243.4	156.0	-	-	-	416.7	47.3	310.5	228.4	146.4			
	72	441.9	45.0	372.4	298.7	225.1	151.4	77.7	4.1	407.1	48.0	352.8	281.3	209.8	138.3	66.7	
	67	421.1	44.6	413.9	354.0	294.1	224.8	155.5	86.2	397.5	47.7	395.1	334.1	273.1	208.1	143.0	78.0
	62	418.9	43.9	415.7	392.2	339.3	286.3	233.3	180.4	396.6	47.0	396.0	372.8	321.6	270.5	219.3	168.1
	57	417.5	43.3	417.5	400.1	382.7	346.9	311.1	275.3	396.9	46.3	396.9	382.3	367.7	331.6	295.5	259.5
16000	77	469.0	46.5	368.7	262.6	156.6	-	-	-	425.5	48.7	347.0	249.1	151.3			
	72	452.2	47.7	398.6	315.2	231.7	148.2	64.8		418.2	50.7	376.6	295.8	215.0	134.2	53.4	
	67	435.5	47.3	428.6	367.7	306.8	232.2	157.5	82.9	411.0	50.3	406.2	342.5	278.7	212.0	145.3	78.5
	62	431.4	46.7	428.7	405.3	353.6	302.0	250.3	198.6	409.2	49.6	408.0	382.0	333.7	285.5	237.2	188.9
	57	428.8	46.0	428.8	412.9	397.1	370.1	343.0	316.0	409.8	49.0	409.8	396.7	383.7	356.4	329.1	301.8
18000	72	462.6	50.4	424.9	331.6	238.4	145.1	51.8		429.4	53.3	400.5	310.4	220.2	130.1	40.0	
	67	449.9	50.1	443.3	381.4	319.5	239.5	159.5	79.5	424.6	52.9	417.4	350.9	284.4	216.0	147.5	79.1
	62	443.8	49.4	441.7	418.4	368.0	317.6	267.2	216.8	421.8	52.3	420.0	391.2	345.8	300.5	255.1	209.7
	57	440.1	48.7	440.1	425.8	411.5	393.2	374.9	356.6	422.6	51.6	422.6	411.2	399.8	381.2	362.6	344.1
20000	72	472.9	53.1	451.2	348.1	245.0	141.9	38.8		440.6	55.9	424.3	324.9	225.5	126.0	26.6	
	67	464.3	52.8	458.0	395.1	332.2	246.8	161.5	76.2	438.1	55.5	428.5	359.3	290.0	219.9	149.8	79.7
	62	456.3	52.1	454.7	431.5	382.4	333.3	284.2	235.1	434.4	54.9	432.0	400.4	357.9	315.5	273.0	230.5
	57	451.4	51.5	451.4	438.6	425.9	416.4	406.8	397.3	435.5	54.3	435.5	425.7	415.8	406.0	396.2	386.4

1. These capacities are gross ratings. For net capacity, deduct the supply air blower motor heat (MBH = 3.415 x kW). Refer to the appropriate Blower Performance Table for the kW of the supply air blower motor.  
 2. These ratings include the condenser fan motors and the compressor motors but not the supply air blower motor.

## CFM, STATIC PRESSURE, AND POWER - ALTI- TUDE AND TEMPERATURE CORRECTIONS

The information below should be used to assist in application of product when being applied at altitudes at or exceeding 1000 feet above sea level.

The air flow rates listed in the standard blower performance tables are based on standard air at sea level. As the altitude or temperature increases, the density of air decreases. In

order to use the indoor blower tables for high altitude applications, certain corrections are necessary.

A centrifugal fan is a "constant volume" device. This means that, if the rpm remains constant, the CFM delivered is the same regardless of the density of the air. However, since the air at high altitude is less dense, less static pressure will be generated and less power will be required than a similar application at sea level. Air density correction factors are shown in Table 37 and Figure 21.

**TABLE 37: ALTITUDE CORRECTION FACTORS**

AIR TEMP	ALTITUDE (FEET)										
	0	1000	2000	3000	4000	5000	6000	7000	8000	9000	10000
40	1.060	1.022	0.986	0.950	0.916	0.882	0.849	0.818	0.788	0.758	0.729
50	1.039	1.002	0.966	0.931	0.898	0.864	0.832	0.802	0.772	0.743	0.715
60	1.019	0.982	0.948	0.913	0.880	0.848	0.816	0.787	0.757	0.729	0.701
70	1.000	0.964	0.930	0.896	0.864	0.832	0.801	0.772	0.743	0.715	0.688
80	0.982	0.947	0.913	0.880	0.848	0.817	0.787	0.758	0.730	0.702	0.676
90	0.964	0.929	0.897	0.864	0.833	0.802	0.772	0.744	0.716	0.689	0.663
100	0.946	0.912	0.880	0.848	0.817	0.787	0.758	0.730	0.703	0.676	0.651

The examples below will assist in determining the airflow performance of the product at altitude.

**Example 1:** What are the corrected CFM, static pressure, and BHP at an elevation of 5,000 ft. if the blower performance data is 6,000 CFM, 1.5 IWC and 4.0 BHP?

**Solution:** At an elevation of 5,000 ft the indoor blower will still deliver 6,000 CFM if the rpm is unchanged. However, Table 37 must be used to determine the static pressure and BHP. Since no temperature data is given, we will assume an air temperature of 70°F. Table 37 shows the correction factor to be 0.832.

$$\text{Corrected static pressure} = 1.5 \times 0.832 = 1.248 \text{ IWC}$$

$$\text{Corrected BHP} = 4.0 \times 0.832 = 3.328$$

**Example 2:** A system, located at 5,000 feet of elevation, is to deliver 6,000 CFM at a static pressure of 1.5". Use the unit blower tables to select the blower speed and the BHP requirement.

**Solution:** As in the example above, no temperature information is given so 70°F is assumed.

The 1.5" static pressure given is at an elevation of 5,000 ft. The first step is to convert this static pressure to equivalent sea level conditions.

$$\text{Sea level static pressure} = 1.5 / .832 = 1.80"$$

Enter the blower table at 6000 SCFM and static pressure of 1.8". The rpm listed will be the same rpm needed at 5,000 ft.

Suppose that the corresponding BHP listed in the table is 3.2. This value must be corrected for elevation.

$$\text{BHP at 5,000 ft} = 3.2 \times .832 = 2.66$$

**Example 3:** Plotting fan performance using the charts provided on pages 38, 40 & 42.

Refer to figure 22, Fan Performance 40 Ton Example determine internal unit static loss. In this case the loss is approximately 1.6" IWC.

Plot the fan performance at cooling sea level 0' elevation. Design conditions: 40 ton unit producing 14,000 CFM @ 1.5 ESP with additional static losses for an economizer and 6", 65% air filters.

Economizer additional static loss = .28" IWC  
Filter additional static loss 6", 65% = .46" IWC

Add the external static pressure and any additional losses to the internal static loss:

External static loss = 1.5" IWC  
Economizer additional static loss = .28" IWC  
Filter additional static loss 6", 65% = .46" IWC  
Internal unit static loss = 1.6" IWC  
Total system static = 3.84 IWC

# Altitude/Temperature Conversion Factor

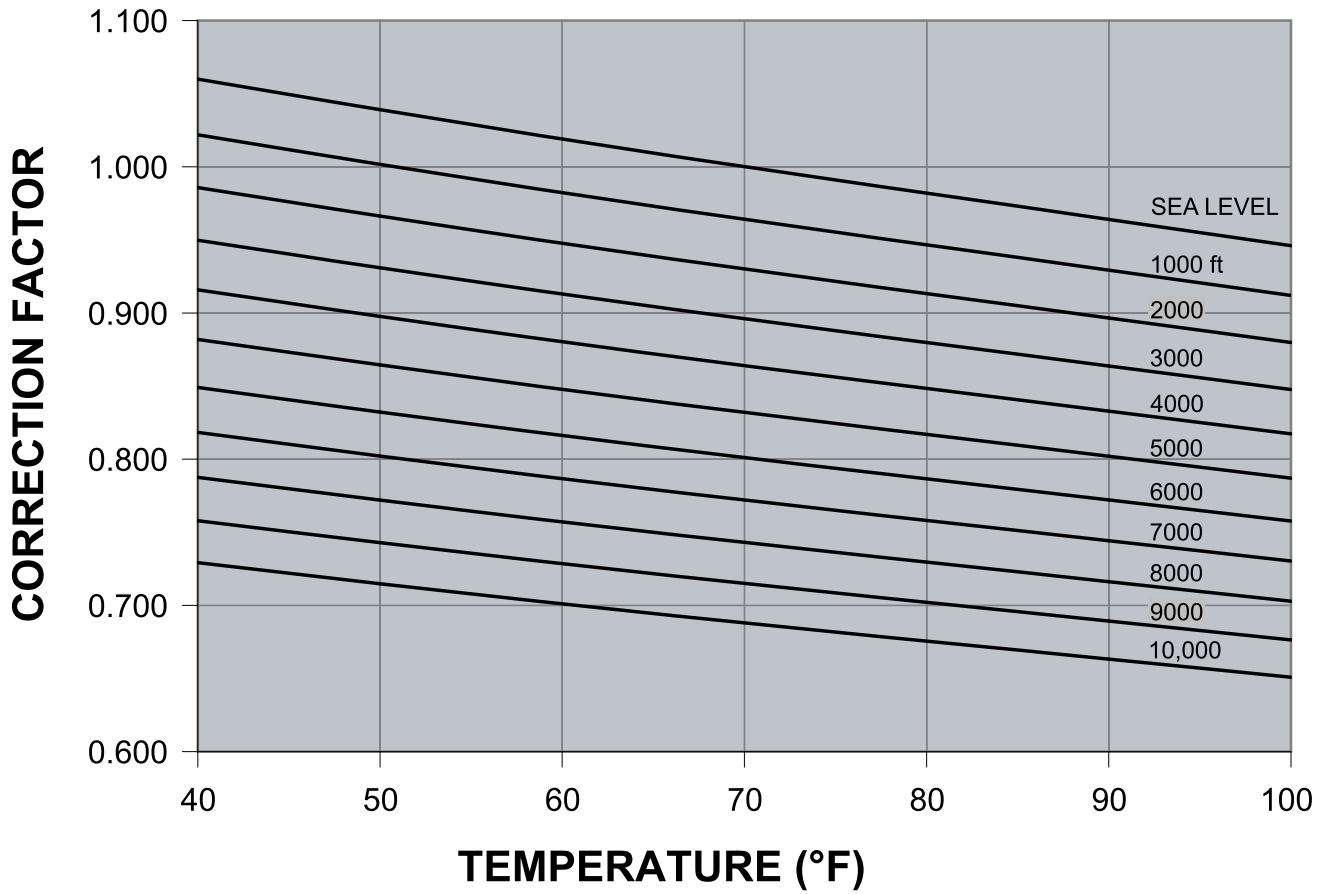

FIGURE 21 - ALTITUDE/TEMPERATURE CONVERSION FACTOR

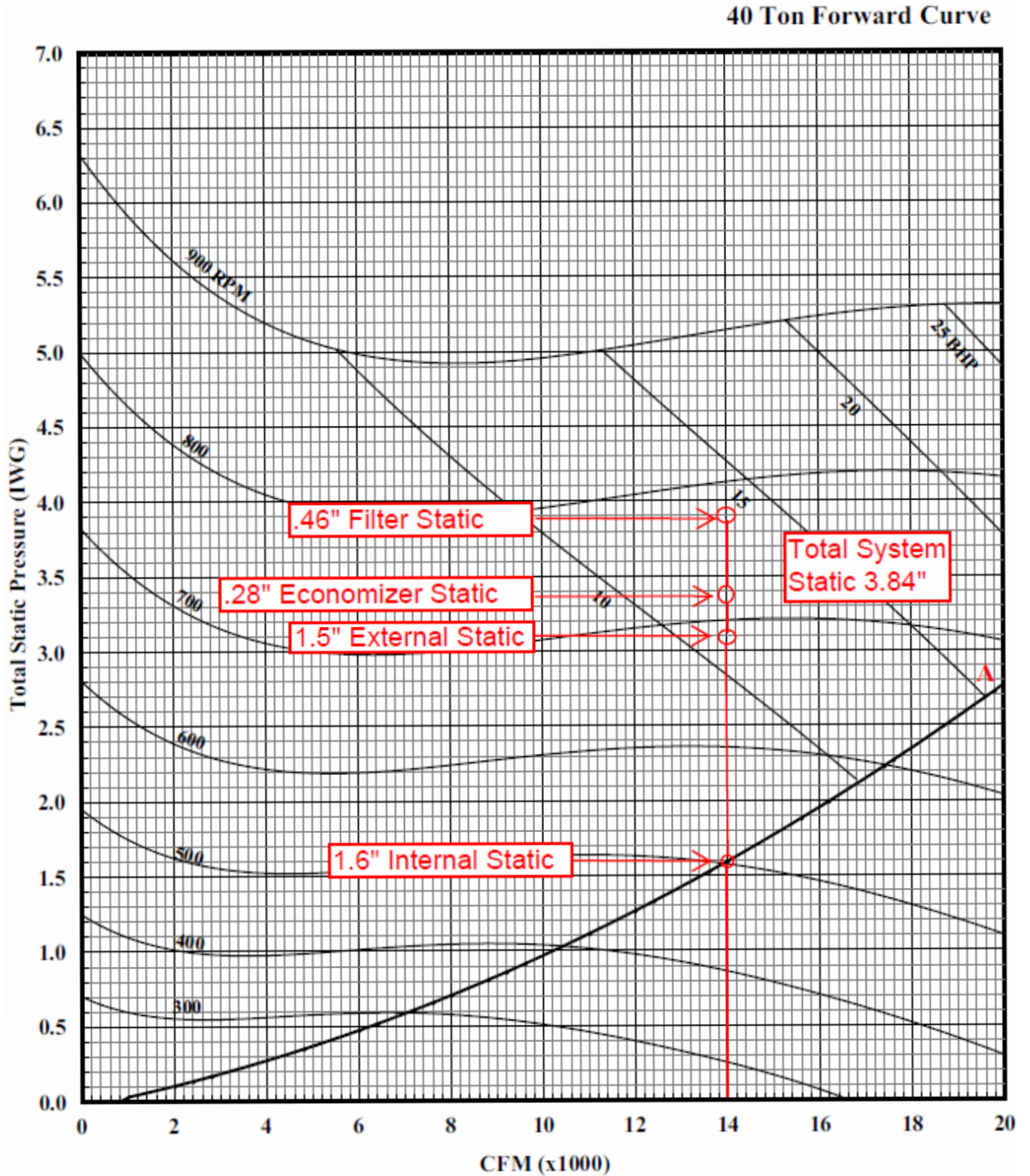

FIGURE 22 - 40 TON FORWARD CURVE EXAMPLE

TABLE 38: FAN PERFORMANCE - 25 TON<sup>1, 2</sup>

AIRFLOW CFM	AVAILABLE EXTERNAL STATIC PRESSURE (IWG)									
	0.2		0.4		0.6		0.8		1.0	
	RPM	BHP <sup>3</sup>	RPM	BHP <sup>3</sup>	RPM	BHP <sup>3</sup>	RPM	BHP <sup>3</sup>	RPM	BHP <sup>3</sup>
4000	302	0.5	365	0.7	422	1.0	475	1.3	523	1.5
5000	341	0.9	396	1.1	447	1.4	495	1.7	540	2.0
6000	380	1.2	427	1.5	473	1.8	516	2.1	557	2.5
7000	416	1.8	459	2.1	500	2.5	540	2.8	578	3.2
8000	452	2.3	491	2.7	528	3.1	565	3.5	600	3.9
9000	492	3.2	527	3.6	561	4.0	594	4.5	626	4.9
10000	532	4.2	563	4.5	594	4.9	624	5.4	653	5.8
11000	578	5.5	605	5.9	632	6.3	659	6.7	686	7.2
12000	623	6.8	647	7.2	671	7.6	695	8.1	719	8.6
12500	639	7.4	664	7.9	688	8.4	712	8.9	736	9.5

AIRFLOW CFM	AVAILABLE EXTERNAL STATIC PRESSURE (IWG)									
	1.2		1.4		1.6		1.8		2.0	
	RPM	BHP <sup>3</sup>	RPM	BHP <sup>3</sup>	RPM	BHP <sup>3</sup>	RPM	BHP <sup>3</sup>	RPM	BHP <sup>3</sup>
4000	568	1.8	609	2.2	646	2.5	681	2.8	713	3.2
5000	582	2.4	621	2.7	657	3.1	692	3.5	724	3.9
6000	596	2.9	633	3.3	669	3.7	702	4.1	735	4.5
7000	615	3.6	650	4.0	683	4.5	716	4.9	747	5.4
8000	633	4.4	666	4.8	698	5.3	729	5.7	759	6.2
9000	658	5.3	688	5.8	718	6.3	747	6.8	776	7.3
10000	682	6.3	710	6.8	738	7.3	766	7.8	793	8.4
11000	713	7.7	739	8.2	765	8.8	791	9.3	816	9.9
12000	743	9.1	767	9.7	791	10.2	815	10.8	839	11.4
12500	760	10.0	784	10.6	807	11.2	830	11.7	853	12.3

AIRFLOW CFM	AVAILABLE EXTERNAL STATIC PRESSURE (IWG)									
	2.2		2.4		2.6		2.8		3.0	
	RPM	BHP <sup>3</sup>	RPM	BHP <sup>3</sup>	RPM	BHP <sup>3</sup>	RPM	BHP <sup>3</sup>	RPM	BHP <sup>3</sup>
4000	743	3.5	770	3.9	796	4.3	821	4.6	844	5.0
5000	754	4.3	783	4.7	810	5.1	836	5.5	861	5.9
6000	766	5.0	795	5.4	824	5.9	851	6.4	878	6.8
7000	777	5.8	806	6.3	834	6.8	861	7.3	888	7.8
8000	788	6.7	817	7.2	844	7.7	871	8.2	898	8.8
9000	804	7.8	831	8.3	857	8.9	883	9.5	909	10.0
10000	819	8.9	845	9.5	870	10.1	896	10.7	920	11.3
11000	841	10.5	866	11.1	890	11.7	914	12.3	938	12.9
12000	863	12.0	887	12.6	910	13.2	933	13.9	956	14.5
12500	876	12.9	899	13.6	921	14.2	943	14.8	965	15.5

AIRFLOW CFM	AVAILABLE EXTERNAL STATIC PRESSURE (IWG)									
	3.2		3.4		3.6		3.8		4.0	
	RPM	BHP <sup>3</sup>	RPM	BHP <sup>3</sup>	RPM	BHP <sup>3</sup>	RPM	BHP <sup>3</sup>	RPM	BHP <sup>3</sup>
4000	867	5.4	890	5.8	912	6.2	935	6.6	958	6.9
5000	885	6.4	909	6.8	932	7.2	956	7.6	979	8.0
6000	903	7.3	928	7.8	953	8.2	976	8.7	1000	9.1
7000	914	8.3	939	8.8	963	9.4	988	9.9	1012	10.5
8000	924	9.3	949	9.9	974	10.5	999	11.2	1023	11.8
9000	934	10.6	959	11.2	983	11.9	1007	12.5	1030	13.2
10000	944	11.9	968	12.6	992	13.2	1015	13.8	1037	14.5
11000	961	13.6	984	14.2	1007	14.9	1029	15.6	1051	16.2
12000	978	15.2	1000	15.9	1022	16.6	1043	17.3	1064	18.0
13000	986	16.2	1008	16.8	1029	17.5	1050	18.2	1070	19.0

1. Fan performance is based on wet evaporator coils, clean 2" throwaway filters and system/cabinet effects at standard air density and 0 feet elevation.
2. Refer to Tables 10, 15, 21 and 41 for component additions and deductions to fan performance tables.
3. BHP includes drive losses.
4. Shaded RPMs require Class II blower.



### 25 Ton Forward Curve

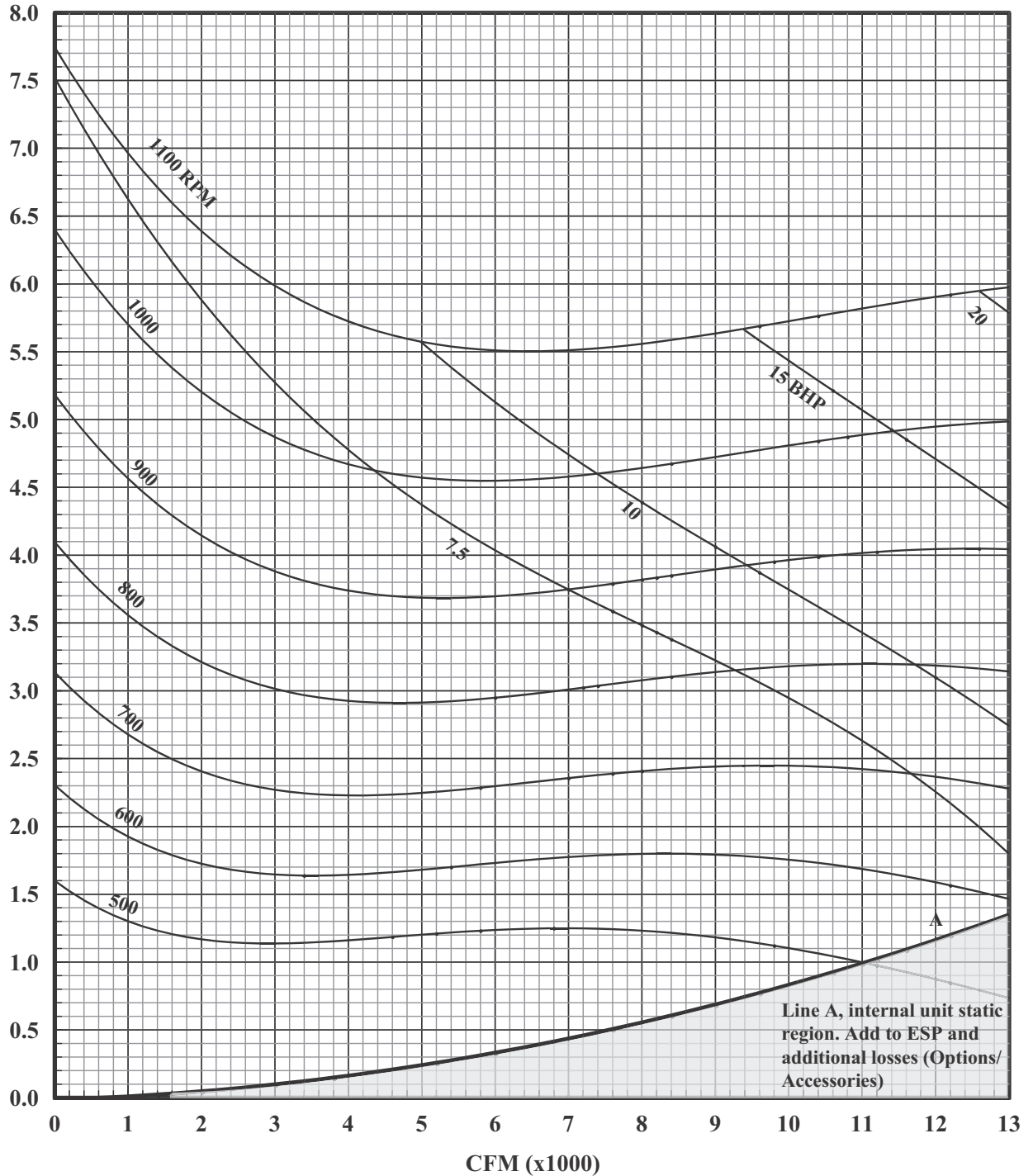

**NOTE:** All areas below the "A" curve are fixed, internal cabinet losses and should be considered when determining total system static and plotting unit fan performance.

**NOTE:** Standard Unit includes wet evaporator coil, clean 2" throwaway filters, system and cabinet effects at standard air density and 0' elevation.

**FIGURE 23 - FAN PERFORMANCE - 25 TON**

TABLE 39: FAN PERFORMANCE - 30 TON <sup>1, 2</sup>

AIRFLOW (CFM)	AVAILABLE EXTERNAL STATIC PRESSURE (IWG)									
	0.2		0.4		0.6		0.8		1.0	
	RPM	BHP <sup>3</sup>	RPM	BHP <sup>3</sup>	RPM	BHP <sup>3</sup>	RPM	BHP <sup>3</sup>	RPM	BHP <sup>3</sup>
6000	405	1.3	450	1.6	494	2.0	535	2.3	575	2.7
7000	444	1.9	485	2.3	524	2.7	562	3.0	599	3.4
8000	483	2.6	519	2.9	555	3.3	589	3.7	623	4.2
9000	520	3.5	554	3.9	586	4.3	618	4.7	649	5.2
10000	558	4.5	588	4.8	618	5.2	647	5.7	676	6.2
11000	603	5.7	629	6.2	656	6.7	683	7.2	709	7.7
12000	647	7.0	671	7.5	695	8.1	718	8.6	742	9.2
13000	687	8.9	709	9.3	731	9.9	753	10.4	776	10.9
14000	728	10.7	748	11.2	768	11.6	789	12.2	809	12.7
15000	767	12.7	786	13.2	805	13.8	825	14.4	845	15.0

AIRFLOW (CFM)	AVAILABLE EXTERNAL STATIC PRESSURE (IWG)									
	1.2		1.4		1.6		1.8		2.0	
	RPM	BHP <sup>3</sup>	RPM	BHP <sup>3</sup>	RPM	BHP <sup>3</sup>	RPM	BHP <sup>3</sup>	RPM	BHP <sup>3</sup>
6000	612	3.1	649	3.5	683	3.9	717	4.3	748	4.7
7000	634	3.8	668	4.3	701	4.7	733	5.1	763	5.6
8000	655	4.6	687	5.1	719	5.5	749	6.0	779	6.5
9000	680	5.6	710	6.1	739	6.6	768	7.2	796	7.7
10000	704	6.7	732	7.2	760	7.7	787	8.3	813	8.9
11000	735	8.2	761	8.7	787	9.3	812	9.8	837	10.4
12000	766	9.7	790	10.3	814	10.8	837	11.4	861	12.0
13000	798	11.5	820	12.1	843	12.7	865	13.3	887	13.9
14000	830	13.3	851	13.9	872	14.6	893	15.2	914	15.9
15000	864	15.6	884	16.3	904	16.9	923	17.6	943	18.3

AIRFLOW (CFM)	AVAILABLE EXTERNAL STATIC PRESSURE (IWG)									
	2.2		2.4		2.6		2.8		3.0	
	RPM	BHP <sup>3</sup>	RPM	BHP <sup>3</sup>	RPM	BHP <sup>3</sup>	RPM	BHP <sup>3</sup>	RPM	BHP <sup>3</sup>
6000	779	5.1	808	5.5	837	6.0	864	6.4	890	6.9
7000	793	6.1	822	6.6	850	7.0	877	7.5	903	8.1
8000	807	7.0	836	7.6	863	8.1	890	8.6	916	9.2
9000	823	8.3	850	8.8	877	9.4	902	10.0	928	10.6
10000	839	9.5	865	10.1	890	10.7	915	11.3	940	12.0
11000	862	11.0	886	11.6	910	12.2	934	12.9	957	13.5
12000	884	12.5	907	13.2	930	13.8	953	14.4	975	15.0
13000	909	14.6	931	15.2	953	15.9	975	16.5	996	17.2
14000	935	16.6	956	17.3	976	18.0	997	18.7	1017	19.4
15000	963	18.9	982	19.6	1002	20.4	1021	21.1	1040	21.8

AIRFLOW (CFM)	AVAILABLE EXTERNAL STATIC PRESSURE (IWG)									
	3.2		3.4		3.6		3.8		4.0	
	RPM	BHP <sup>3</sup>	RPM	BHP <sup>3</sup>	RPM	BHP <sup>3</sup>	RPM	BHP <sup>3</sup>	RPM	BHP <sup>3</sup>
6000	916	7.4	940	7.9	964	8.3	988	8.8	1011	9.3
7000	928	8.6	953	9.1	977	9.6	1000	10.1	1023	10.7
8000	941	9.8	965	10.3	989	10.9	1013	11.5	1035	12.0
9000	952	11.2	976	11.8	1000	12.4	1023	13.0	1045	13.6
10000	964	12.6	987	13.2	1010	13.9	1033	14.5	1055	15.1
11000	981	14.1	1003	14.8	1025	15.5	1047	16.1	1069	16.8
12000	997	15.7	1019	16.4	1040	17.1	1061	17.8	1082	18.5
13000	1017	17.9	1038	18.6	1058	19.4	1078	20.1	1097	20.8
14000	1037	20.2	1056	20.9	1076	21.6	1094	22.4	1113	23.1
15000	1059	22.6	1078	23.3	1097	24.1	1115	24.9	1134	25.7

1. Fan performance is based on wet evaporator coils, clean 2" throwaway filters and system/cabinet effects at standard air density and 0 feet elevation.

2. Refer to Tables 10, 15, 21 and 41 for component additions and deductions to fan performance tables.

3. BHP includes drive losses.

4. Shaded RPMs require Class II blower.

30 Ton Forward Curve

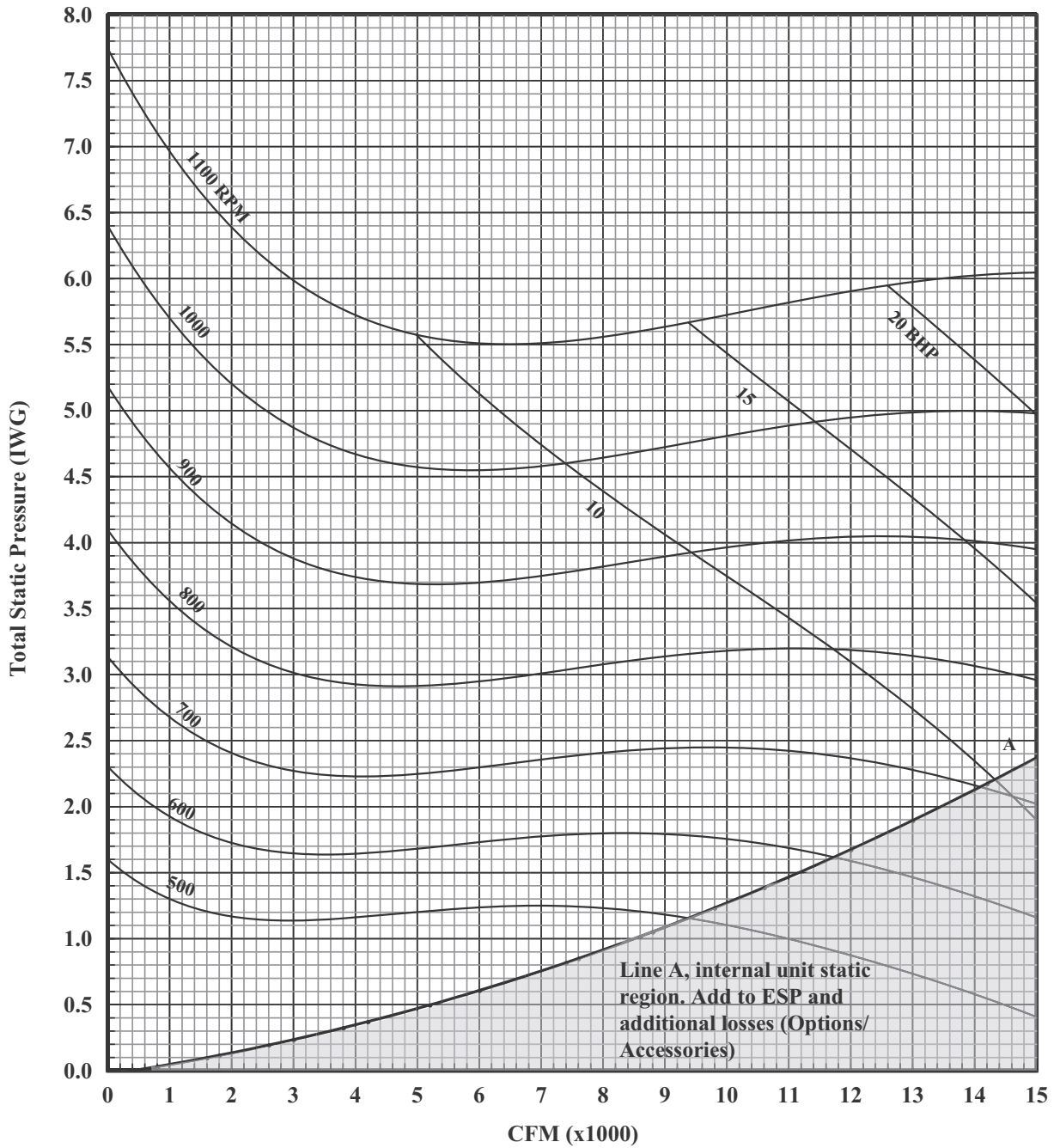

**NOTE:** All areas below the "A" curve are fixed, internal cabinet losses and should be considered when determining total system static and plotting unit fan performance.

**NOTE:** Standard Unit includes wet evaporator coil, clean 2" throwaway filters, system and cabinet effects at standard air density and 0' elevation.

**FIGURE 24 - FAN PERFORMANCE - 30 TON**

TABLE 40: FAN PERFORMANCE - 40 TON<sup>1,2</sup>

AIRFLOW (CFM)	AVAILABLE EXTERNAL STATIC PRESSURE (IWG)									
	0.2		0.4		0.6		0.8		1.0	
	RPM	BHP <sup>3</sup>	RPM	BHP <sup>3</sup>	RPM	BHP <sup>3</sup>	RPM	BHP <sup>3</sup>	RPM	BHP <sup>3</sup>
8000	320	1.3	368	1.7	412	2.2	452	2.7	488	3.2
9000	356	1.8	396	2.3	435	2.8	472	3.3	506	3.8
10000	385	2.3	422	2.8	457	3.3	491	3.8	522	4.4
11000	410	3.0	445	3.5	478	4.1	510	4.6	540	5.1
12000	436	3.6	468	4.2	500	4.8	529	5.3	558	5.9
13000	455	4.3	486	4.9	516	5.5	546	6.2	573	6.8
14000	477	5.0	508	5.7	536	6.4	563	7.1	590	7.8
15000	508	6.3	535	7.0	563	7.6	588	8.4	612	9.2
16000	538	7.5	564	8.2	588	9.0	612	9.7	635	10.5
17000	561	9.0	586	9.7	610	10.5	633	11.2	656	12.0
18000	585	10.5	609	11.3	632	12.0	654	12.8	677	13.6

AIRFLOW (CFM)	AVAILABLE EXTERNAL STATIC PRESSURE (IWG)									
	1.2		1.4		1.6		1.8		2.0	
	RPM	BHP <sup>3</sup>	RPM	BHP <sup>3</sup>	RPM	BHP <sup>3</sup>	RPM	BHP <sup>3</sup>	RPM	BHP <sup>3</sup>
8000	523	3.6	556	4.1	586	4.6	614	5.1	641	5.6
9000	538	4.3	568	4.8	598	5.3	625	5.9	652	6.4
10000	552	4.9	582	5.5	610	6.0	636	6.5	662	7.1
11000	569	5.7	596	6.3	623	6.9	649	7.5	674	8.1
12000	585	6.6	612	7.2	637	7.8	662	8.5	686	9.1
13000	599	7.5	626	8.1	650	8.8	674	9.5	699	10.2
14000	616	8.5	641	9.2	666	9.9	689	10.7	712	11.4
15000	637	9.9	660	10.6	684	11.3	707	12.1	729	12.9
16000	658	11.3	680	12.0	702	12.8	724	13.6	745	14.3
17000	678	12.9	699	13.6	721	14.4	742	15.3	762	16.1
18000	697	14.5	718	15.3	739	16.1	760	16.9	780	17.8

AIRFLOW (CFM)	AVAILABLE EXTERNAL STATIC PRESSURE (IWG)									
	2.2		2.4		2.6		2.8		3.0	
	RPM	BHP <sup>3</sup>	RPM	BHP <sup>3</sup>	RPM	BHP <sup>3</sup>	RPM	BHP <sup>3</sup>	RPM	BHP <sup>3</sup>
8000	667	6.1	691	6.6	715	7.1	737	7.5	759	8.1
9000	677	6.9	702	7.4	725	8.0	747	8.6	769	9.2
10000	687	7.8	712	8.4	735	9.0	758	9.7	779	10.3
11000	698	8.8	722	9.4	745	10.1	767	10.8	789	11.5
12000	709	9.8	732	10.5	755	11.2	777	11.8	798	12.5
13000	722	10.9	743	11.7	765	12.4	787	13.1	808	13.9
14000	734	12.2	756	12.9	778	13.7	798	14.4	819	15.2
15000	750	13.6	771	14.4	791	15.2	812	16.0	832	16.9
16000	765	15.1	785	15.9	805	16.8	825	17.6	844	18.4
17000	782	16.9	801	17.8	821	18.6	840	19.5	858	20.4
18000	799	18.7	818	19.6	837	20.5	855	21.4	874	22.3

AIRFLOW (CFM)	AVAILABLE EXTERNAL STATIC PRESSURE (IWG)									
	3.2		3.4		3.6		3.8		4.0	
	RPM	BHP <sup>3</sup>	RPM	BHP <sup>3</sup>	RPM	BHP <sup>3</sup>	RPM	BHP <sup>3</sup>	RPM	BHP <sup>3</sup>
8000	780	8.6	800	9.2	821	9.9	841	10.5	861	11.2
9000	790	9.8	811	10.5	831	11.1	852	11.8	872	12.5
10000	801	11.0	821	11.7	842	12.3	862	12.9	882	13.6
11000	809	12.2	831	12.8	850	13.5	871	14.2	890	14.9
12000	819	13.2	839	14.0	859	14.7	879	15.4	899	16.1
13000	828	14.7	848	15.4	868	16.2	887	17.0	907	17.7
14000	839	16.0	858	16.8	878	17.6	896	18.4	915	19.2
15000	850	17.7	870	18.5	889	19.3	907	20.1	926	21.0
16000	863	19.3	882	20.2	900	21.1	918	22.0	936	22.8
17000	877	21.3	896	22.2	913	23.1	931	23.8	944	24.6
18000	891	23.3	910	24.2	928	25.1	946	26.1	-	-

1. Fan performance is based on wet evaporator coils, clean 2" throwaway filters and system/cabinet effects at standard air density and 0 feet elevation.
2. Refer to Tables 12, 18, 23 and 41 for component additions and deductions to fan performance tables.
3. BHP includes drive losses.
4. Shaded RPMs require Class II blower.

### 40 Ton Forward Curve

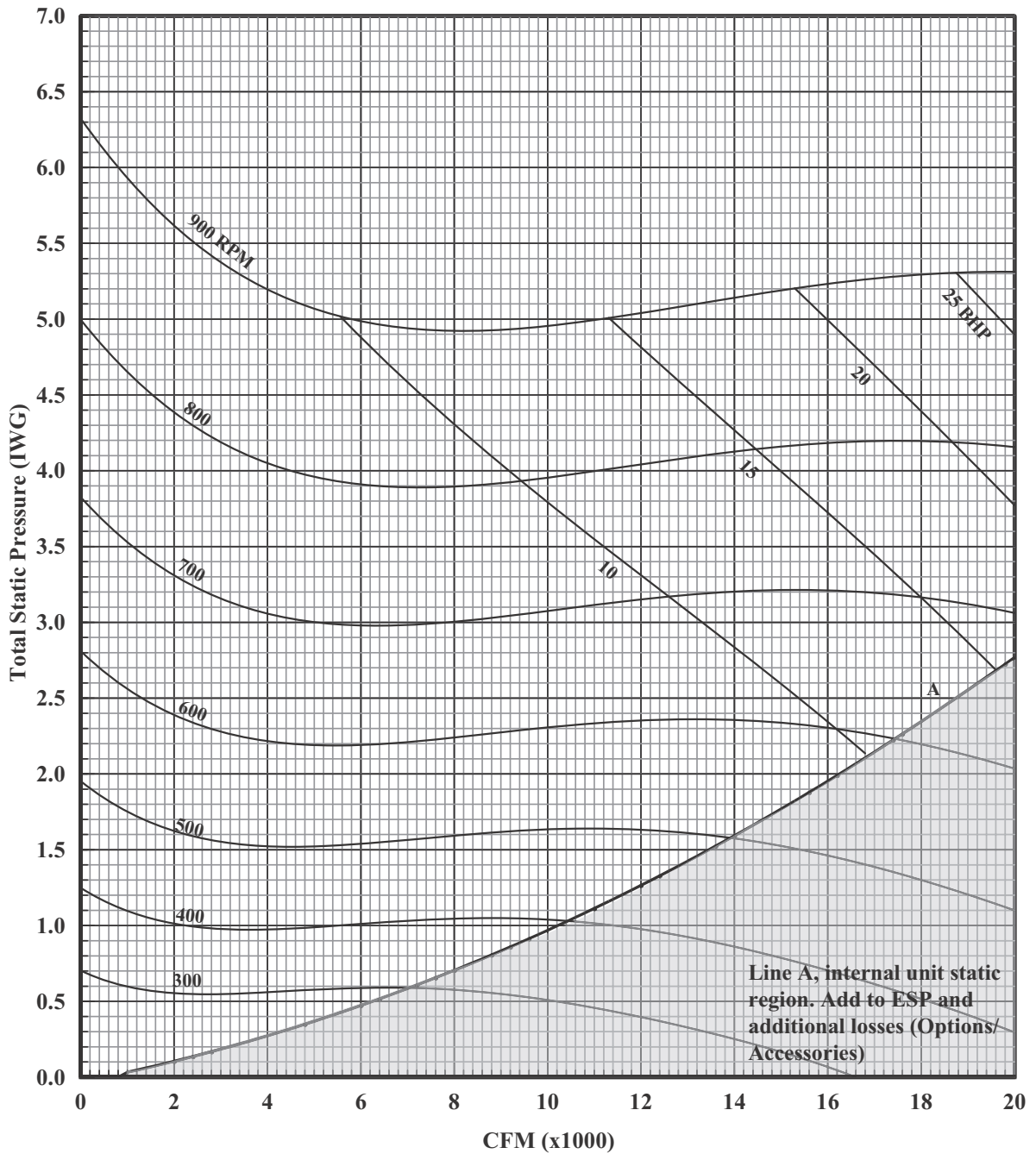

**NOTE:** All areas below the "A" curve are fixed, internal cabinet losses and should be considered when determining total system static and plotting unit fan performance.

**NOTE:** Standard Unit includes wet evaporator coil, clean 2" throwaway filters, system and cabinet effects at standard air density and 0' elevation.

**FIGURE 25 - FAN PERFORMANCE - 40 TON**

**TABLE 41: COMPONENT STATIC RESISTANCE<sup>1, 2</sup>**

COMPONENT COIL LOSSES	CFM							
	4,000	6,000	8,000	10,000	12,000	14,000	16,000	18,000
<b>COIL LOSSES 25T</b>								
3 Row, 16 FPI, dry	-0.14	-0.18	-0.24	-0.34	-0.45	-	-	-
3 Row, 16 FPI, wet	Baseline	Baseline	Baseline	Baseline	Baseline	-	-	-
<b>COIL LOSSES 30T</b>								
4 Row, 16 FPI, dry	-0.18	-0.22	-0.32	-0.45	-0.60	-0.76	-	-
4 Row, 16 FPI, wet	Baseline	Baseline	Baseline	Baseline	Baseline	Baseline	-	-
<b>COIL LOSSES 40T</b>								
4 Row, 16 FPI, dry	-0.022	-0.082	-0.123	-0.204	-0.263	-0.391	-0.494	-0.607
4 Row, 16 FPI, wet	Baseline	Baseline	Baseline	Baseline	Baseline	Baseline	Baseline	Baseline
<b>FILTER LOSSES</b>								
2" TA or HI EFF.	Baseline	Baseline	Baseline	Baseline	Baseline	Baseline	Baseline	Baseline
Rigid 6", 65%	0.06	0.12	0.19	0.27	0.36	0.46	0.58	0.70
Rigid 6", 95%	0.13	0.26	0.41	0.60	0.81	1.04	1.29	1.57
<b>IGV LOSSES</b>								
25 & 30 Ton F.C.	0.02	0.05	0.08	0.13	0.19	0.26	0.34	0.43
40 Ton F.C.	0.01	0.03	0.05	0.08	0.11	0.15	0.19	0.25
<b>GAS HEAT</b>								
267 MBH Heat	0.07	0.11	0.14	0.18	0.21	0.25	0.28	0.32
533 MBH Heat	0.14	0.21	0.28	0.35	0.42	0.49	0.57	0.64
800 MBH Heat	0.21	0.32	0.42	0.53	0.64	0.74	0.85	0.95
<b>ELECTRIC HEAT</b>								
40KW	0.01	0.02	0.04	0.06	0.10	0.20	0.31	0.40
80KW	0.01	0.04	0.08	0.13	0.20	0.31	0.44	0.56
108KW	0.02	0.05	0.10	0.15	0.31	0.43	0.53	0.68
<b>ECONOMIZER</b>								
	0.03	0.06	0.10	0.15	0.21	0.28	0.35	0.43
<b>POWER EXHAUST</b>								
	0.02	0.05	0.08	0.13	0.18	0.25	0.32	0.41

1. Baseline losses based on system/cabinet effects, wet standard coil and 2" throwaway filters at 70°F, 0 feet elevation with standard air.

2. See Tables 10, 12, 15, 18 and 21 for hot water and steam water coil static resistance.

**TABLE 42: POWER EXHAUST - ONE FORWARD CURVED FAN 25 TON<sup>1</sup>**

AIRFLOW CFM	AVAILABLE EXTERNAL STATIC PRESSURE (IWG)									
	0.2		0.4		0.6		0.8		1.0	
	RPM	BHP <sup>2</sup>	RPM	BHP <sup>2</sup>	RPM	BHP <sup>2</sup>	RPM	BHP <sup>2</sup>	RPM	BHP <sup>2</sup>
2000	---	---	---	---	524	0.3	609	0.4	685	0.6
3000	---	---	450	0.4	531	0.5	605	0.7	672	0.8
4000	442	0.7	496	0.8	562	0.9	626	1.1	687	1.2
5000	524	1.2	566	1.4	609	1.5	663	1.7	717	1.8
6000	612	1.9	646	2.2	679	2.4	717	2.6	762	2.7
7000	703	3.0	731	3.3	759	3.5	787	3.7	820	4.0
8000	791	3.8	821	4.3	844	4.8	868	5.2	892	5.5
9000	877	5.8	911	6.2	932	6.5	953	6.9	974	7.3
10000	967	8.4	1004	8.8	1022	9.1	1041	9.4	1059	9.8

AIRFLOW CFM	AVAILABLE EXTERNAL STATIC PRESSURE (IWG)									
	1.2		1.4		1.6		1.8		2.0	
	RPM	BHP <sup>2</sup>	RPM	BHP <sup>2</sup>	RPM	BHP <sup>2</sup>	RPM	BHP <sup>2</sup>	RPM	BHP <sup>2</sup>
2000	754	0.7	819	0.8	878	0.9	933	1.1	986	1.2
3000	736	1.0	797	1.1	854	1.3	909	1.5	961	1.7
4000	743	1.4	799	1.5	850	1.7	900	1.9	948	2.1
5000	768	2.0	818	2.2	865	2.4	911	2.6	955	2.8
6000	806	2.9	850	3.1	895	3.3	937	3.6	978	3.8
7000	857	4.2	895	4.4	933	4.6	972	4.8	1010	5.0
8000	921	5.7	953	6.0	985	6.2	1018	6.5	1052	6.8
9000	995	7.6	1020	8.0	1048	8.3	1075	8.5	1103	8.8
10000	1077	10.1	1096	10.4	1119	10.8	1143	11.1	1167	11.4

1. Fan performance is based on system/cabinet effects and back draft damper effects at standard air density and 0 feet of elevation.
2. BHP includes 5% drive losses.

**Power Exhaust 25 Ton**

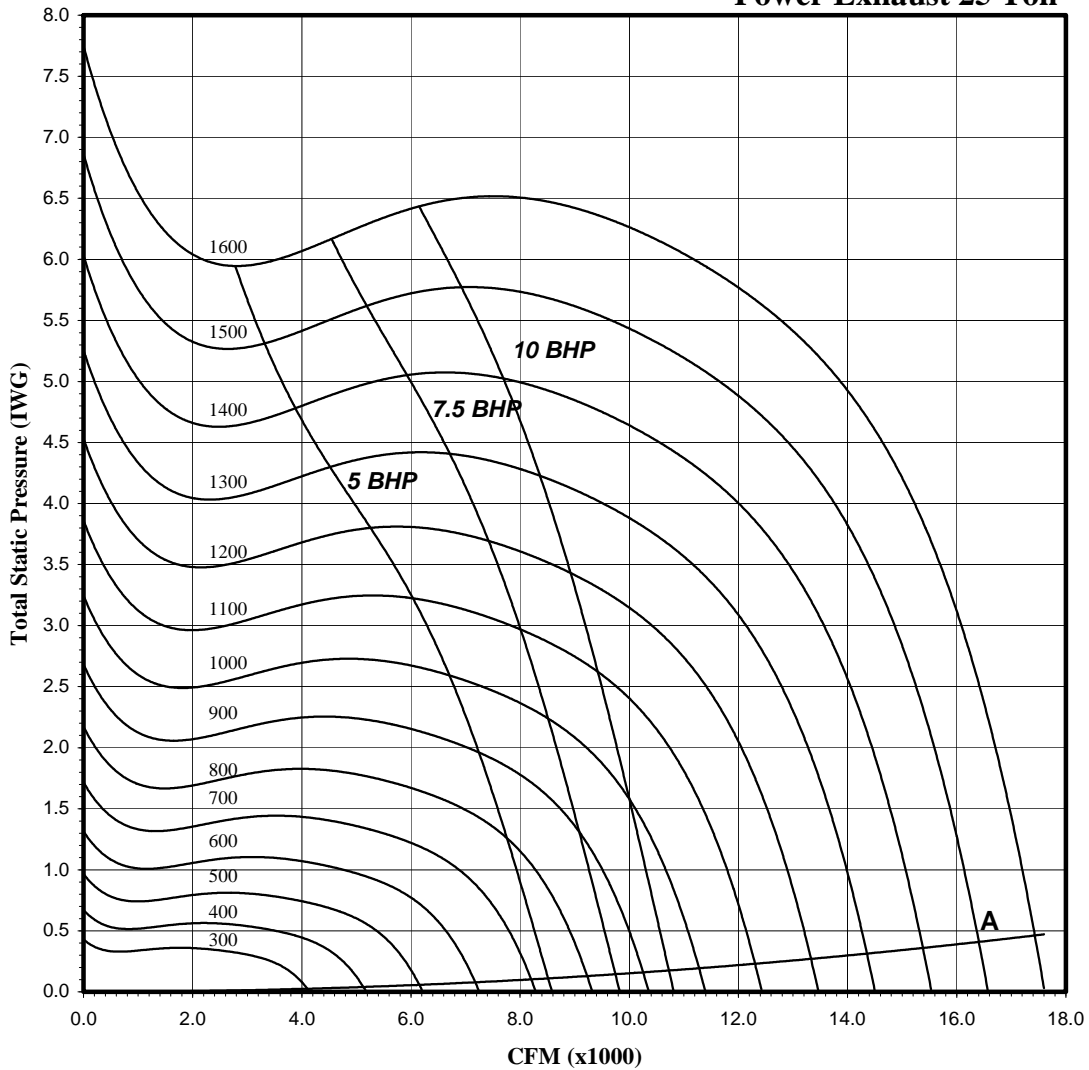

Line "A" internal unit static region. Add to ESP and additional losses (Options/ Accessories) to determine total system static.

**NOTE:** All areas below the "A" curve are fixed, internal cabinet losses and should be considered when determining total system static and plotting unit fan performance.

**NOTE:** Standard Unit includes wet evaporator coil, clean 2" throwaway filters, system and cabinet effects at standard air density and 0' elevation.

**FIGURE 26 - POWER EXHAUST - ONE FORWARD CURVE FAN - 25 TONS**



**TABLE 43: POWER EXHAUST - TWO FORWARD CURVED FANS - 30 & 40 TON<sup>1</sup>**

AIRFLOW CFM	AVAILABLE EXTERNAL STATIC PRESSURE (IWG)									
	0.2		0.4		.06		0.8		1.0	
	RPM	BHP <sup>2 3</sup>	RPM	BHP <sup>2 3</sup>	RPM	BHP <sup>2 3</sup>	RPM	BHP <sup>2 3</sup>	RPM	BHP <sup>2 3</sup>
4000	363	0.3	468	0.5	560	0.7	641	0.9	716	1.2
5000	402	0.5	494	0.7	576	1.1	652	1.3	722	1.5
6000	445	0.8	527	1.1	602	1.4	670	1.7	735	2.0
7000	494	1.3	565	1.6	633	1.8	697	2.1	757	2.5
8000	544	1.8	609	2.1	670	2.4	729	2.7	784	3.2
9000	597	2.4	654	2.8	711	3.2	765	3.5	817	3.9
10000	651	3.3	703	3.7	754	4.0	805	4.4	853	4.8
11000	705	4.3	753	4.7	801	5.1	847	5.6	893	6.0
12000	761	5.5	805	5.9	849	6.3	893	6.8	934	7.2
13000	817	6.9	858	7.4	899	7.8	939	8.3	979	8.8
14000	874	8.5	912	9.0	950	9.6	988	10.0	1025	10.5
15000	932	10.4	967	10.9	1002	11.6	1037	12.1	1072	12.6
16000	989	12.6	1022	13.2	1055	13.8	1088	14.3	---	---

AIRFLOW CFM	AVAILABLE EXTERNAL STATIC PRESSURE (IWG)									
	1.2		1.4		1.6		1.8		2	
	RPM	BHP <sup>2 3</sup>	RPM	BHP <sup>2 3</sup>	RPM	BHP <sup>2 3</sup>	RPM	BHP <sup>2 3</sup>	RPM	BHP <sup>2 3</sup>
4000	783	1.5	844	1.7	903	1.9	956	2.2	1008	2.4
5000	788	1.8	848	2.1	906	2.4	959	2.6	1011	2.9
6000	798	2.2	855	2.6	911	2.9	963	3.3	1014	3.6
7000	814	2.8	869	3.2	922	3.5	972	3.9	1021	4.2
8000	837	3.5	889	3.9	938	4.2	987	4.6	1033	5.0
9000	866	4.3	915	4.7	961	5.1	1007	5.6	1050	6.0
10000	900	5.3	945	5.7	989	6.2	1032	6.6	1073	7.1
11000	936	6.4	979	6.9	1020	7.4	1061	7.9	1101	8.3
12000	976	7.8	1016	8.3	1055	8.7	1094	9.2	1131	9.8
13000	1018	9.3	1055	9.9	1093	10.4	1129	10.9	1165	11.6
14000	1061	11.1	1098	11.7	1133	12.3	1167	12.9	1202	13.4
15000	1107	13.2	1141	13.8	1175	14.4	1208	14.9	1240	15.5
16000	---	---	---	---	---	---	---	---	---	---

1. Fan performance is based on system/cabinet effects and back draft damper effects at standard air density and 0 feet of elevation.
2. BHP includes the sum of both exhaust fan blowers.
3. BHP includes 5% drive losses.

**Power Exhaust**

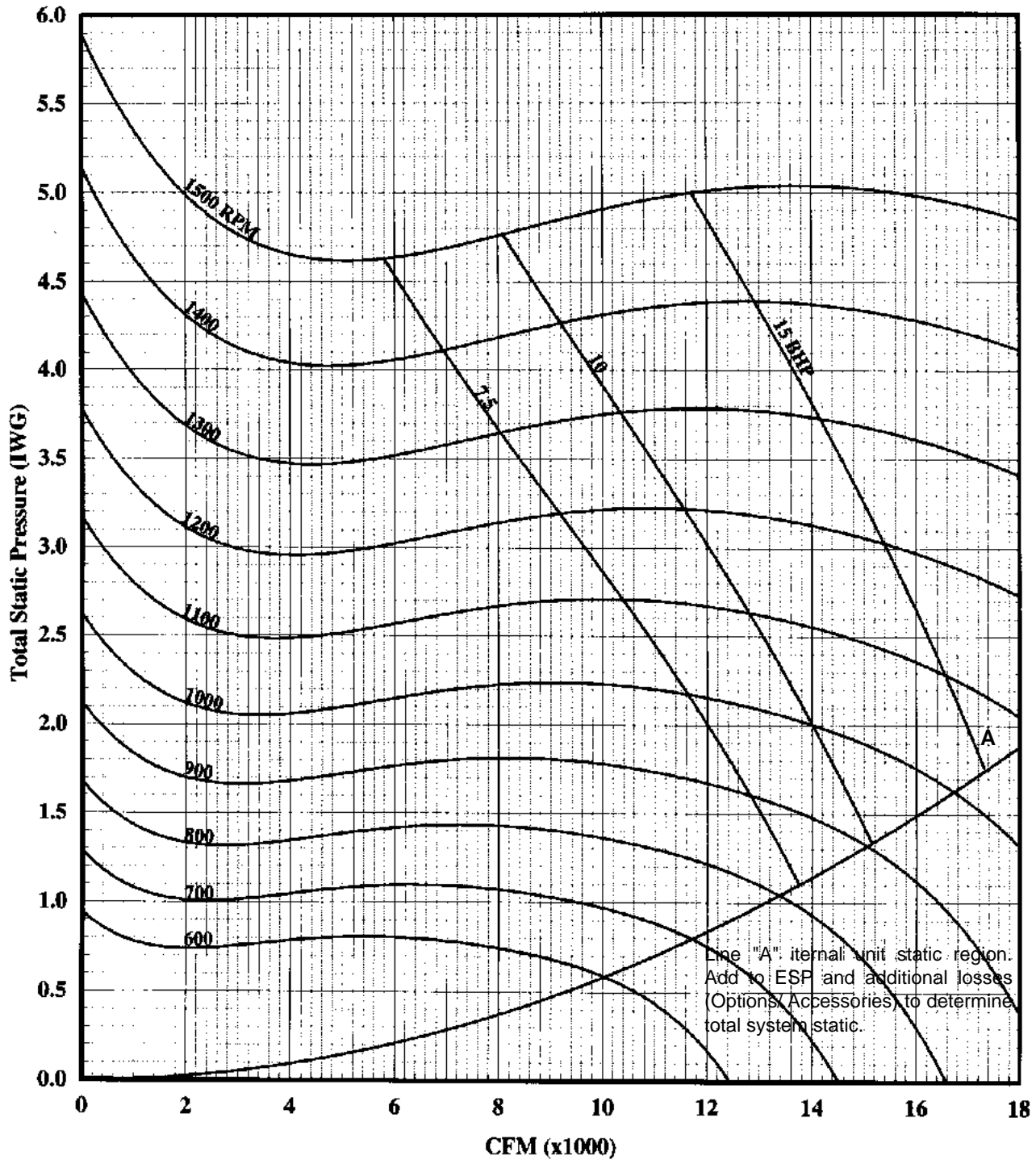

**NOTE:** All areas below the "A" curve are fixed, internal cabinet losses and should be considered when determining total system static and plotting unit fan performance.

**NOTE:** Standard Unit includes wet evaporator coil, clean 2" throwaway filters, system and cabinet effects at standard air density and 0' elevation.

**FIGURE 27 - POWER EXHAUST - TWO FORWARD CURVED FANS - 30 & 40 TONS**

## ELECTRICAL DATA

TABLE 44: ELECTRICAL DATA 25 TON 208/230 VOLT WITHOUT ERV

Voltage	Compressors (each)				OD Fan Motors (each)	Heat Option				Conv Outlet	Supply Blower Motor		Pwr Exh Motor	W/O Pwr Conv Outlet		With Pwr Conv Outlet		
														MCA <sup>1</sup>	Max Fuse <sup>2</sup> / Breaker <sup>3</sup> Size	MCA <sup>1</sup>	Max Fuse <sup>2</sup> / Breaker <sup>3</sup> Size	
	QTY	RLA	LRA	MCC	FLA	Model	kW	Stages	Amps	FLA	HP	FLA	HP	FLA	Amps	Amps	Amps	
208-3-60	4	22.4	149	35	4.5	None/Gas	-	-	-	11.5	7.5	24.2	-	-	138	150	149	150
													5	16.7	155	175	166	175
													7.5	24.2	162	175	174	175
													10	30.8	170	200	182	200
											10	30.8	-	-	146	175	158	175
													5	16.7	163	175	174	200
													7.5	24.2	170	200	182	200
													10	30.8	177	200	188	200
											15	46.2	-	-	165	200	177	200
													5	16.7	182	225	194	225
													7.5	24.2	190	225	201	225
													10	30.8	196	225	208	250
											20	59.4	-	-	182	225	193	250
													5	16.7	199	250	210	250
													7.5	24.2	206	250	218	250
													10	30.8	213	250	224	250
230-3-60	4	22.4	149	35	4.3	None/Gas	-	-	-	10.4	7.5	22	-	-	134	150	145	150
													5	15.2	150	150	160	175
													7.5	22	156	175	167	175
													10	28	164	175	174	200
											10	28	-	-	142	150	152	175
													5	15.2	157	175	167	175
													7.5	22	164	175	174	200
													10	28	170	175	180	200
											15	42	-	-	159	200	170	200
													5	15.2	175	200	185	225
													7.5	22	181	200	192	225
													10	28	187	225	198	225
											20	54	-	-	174	225	185	225
													5	15.2	190	225	200	250
													7.5	22	196	250	207	250
													10	28	202	250	213	250
208-3-60	4	22.4	149	35	4.5	E4	30	1	83	11.5	7.5	24.2	-	-	138	150	149	150
													5	16.7	155	175	166	175
													7.5	24.2	162	175	174	175
													10	30.8	170	200	182	200
											10	30.8	-	-	146	175	158	175
													5	16.7	163	175	174	200
													7.5	24.2	170	200	182	200
													10	30.8	177	200	188	200
											15	46.2	-	-	165	200	177	200
													5	16.7	182	225	194	225
													7.5	24.2	190	225	201	225
													10	30.8	196	225	208	250
											20	59.4	-	-	182	225	193	250
													5	16.7	199	250	210	250
													7.5	24.2	206	250	218	250
													10	30.8	213	250	224	250

**TABLE 44: ELECTRICAL DATA 25 TON 208/230 VOLT WITHOUT ERV (CONT.)**

Voltage	Compressors (each)				OD Fan Motors (each)	Heat Option				Conv Outlet	Supply Blower Motor		Pwr Exh Motor		W/O Pwr Conv Outlet		With Pwr Conv Outlet	
															MCA <sup>1</sup>	Max Fuse <sup>2</sup> / Breaker <sup>3</sup> Size	MCA <sup>1</sup>	Max Fuse <sup>2</sup> / Breaker <sup>3</sup> Size
	QTY	RLA	LRA	MCC	FLA	Model	kW	Stages	Amps	FLA	HP	FLA	HP	FLA	Amps	Amps	Amps	Amps
230-3-60	4	22.4	149	35	4.3	E4	40	1	92	10.4	7.5	22	-	-	143	150	153	175
													5	15.2	158	175	168	175
													7.5	22	165	175	175	175
													10	28	172	200	182	200
											10	28	-	-	150	175	160	175
													5	15.2	165	175	176	200
													7.5	22	172	200	182	200
											15	42	10	28	178	200	188	200
													-	-	168	200	178	200
													5	15.2	183	225	193	225
											20	54	7.5	22	190	225	200	225
													10	28	196	225	206	225
-	-	183	225	193	225													
208-3-60	4	22.4	149	35	4.5	E8	60.1	2	167	11.5	7.5	24.2	-	-	197	225	209	225
													5	16.7	214	225	225	250
													7.5	24.2	221	225	233	250
													10	30.8	230	250	241	250
											10	30.8	-	-	206	225	217	225
													5	16.7	222	250	234	250
													7.5	24.2	230	250	241	250
											15	46.2	10	30.8	236	250	248	250
													-	-	225	250	236	250
													5	16.7	241	250	253	300
											20	59.4	7.5	24.2	249	250	260	300
													10	30.8	256	300	267	300
-	-	241	300	253	300													
230-3-60	4	22.4	149	35	4.3	E8	80	2	185	10.4	7.5	22	-	-	213	250	223	250
													5	15.2	228	250	238	250
													7.5	22	235	250	245	250
													10	28	242	250	252	300
											10	28	-	-	220	250	230	250
													5	15.2	235	250	246	250
													7.5	22	242	250	252	300
											15	42	10	28	248	250	258	300
													-	-	238	250	248	250
													5	15.2	253	300	263	300
											20	54	7.5	22	260	300	270	300
													10	28	266	300	276	300
-	-	253	300	263	300													
20	54	5	15.2	268	300	278	300											
		7.5	22	275	300	285	300											
		10	28	281	300	291	300											

1. Minimum Circuit Ampacity.
2. Dual Element, Time Delay Type.
3. HACR type per NEC.

**TABLE 45: ELECTRICAL DATA 25 TON 230 VOLT WITH ERV**

Voltage	Compressors (each)				OD Fan Motors (Qty 4)	Heat Option				Conv Outlet	Supply Blower Motor		ERV Wheel Motor		ERV Blower Motor (Qty 2)		W/O Pwr'd Conv Outlet		With Pwr'd Conv Outlet	
																	MCA <sup>1</sup>	Max Fuse <sup>2</sup> / Breaker <sup>3</sup> Size	MCA <sup>1</sup>	Max Fuse <sup>2</sup> / Breaker <sup>3</sup> Size
	QTY	RLA	LRA	MCC	FLA	Model	kW	Stages	Amps	FLA	HP	FLA	HP	FLA	HP	FLA	Amps	Amps	Amps	Amps
208-3-60	4	22.4	149	35	4.5	None H2O Gas	-	-	-	11.5	7.5	24.2	0.25	2.5	5	16.7	174	175	185	200
											10	30.8					182	200	194	200
											15	46.2					201	225	213	250
											20	59.4					218	250	229	250
230-3-60	4	22.4	149	35	4.3	None H2O Gas	-	-	-	10.4	7.5	22	0.25	2.5	5	15.2	167	175	178	200
											10	28					175	200	185	200
											15	42					192	225	203	225
											20	54					207	250	218	250
208-3-60	4	22.4	149	35	4.5	E4	30	1	83	11.5	7.5	24.2	0.25	2.5	5	16.7	174	175	185	200
											10	30.8					182	200	194	200
											15	46.2					201	225	213	250
											20	59.4					218	250	229	250
230-3-60	4	22.4	149	35	4.3	E4	40	1	92	10.4	7.5	22	0.25	2.5	5	15.2	175	175	186	200
											10	28					183	200	193	200
											15	42					200	225	211	250
											20	54					215	250	226	250
208-3-60	4	22.4	149	35	4.5	E8	60.1	2	167	11.5	7.5	24.2	0.25	2.5	5	16.7	233	250	245	250
											10	30.8					241	250	253	300
											15	46.2					261	300	272	300
											20	59.4					277	300	289	300
230-3-60	4	22.4	149	35	4.3	E8	80	2	185	10.4	7.5	22	0.25	2.5	5	15.2	245	250	256	300
											10	28					253	300	263	300
											15	42					270	300	281	300
											20	54					285	300	296	350

1. Minimum Circuit Ampacity.
2. Dual Element, Time Delay Type.
3. HACR type per NEC.

**TABLE 46: ELECTRICAL DATA 25 TON 460 VOLT WITHOUT ERV**

Voltage	Compressors (each)				OD Fan Motors (each)	Heat Option				Conv Outlet	Supply Blower Motor		Pwr Exh Motor	W/O Pwr Conv Outlet		With Pwr Conv Outlet		
														MCA <sup>1</sup>	Max Fuse <sup>2</sup> / Breaker <sup>3</sup> Size	MCA <sup>1</sup>	Max Fuse <sup>2</sup> / Breaker <sup>3</sup> Size	
	QTY	RLA	LRA	MCC	FLA	Model	kW	Stages	Amps	FLA	HP	FLA	HP	FLA	Amps	Amps	Amps	Amps
460-3-60	4	10.6	75	16.5	2.15	None/ Gas	-	-	-	5.2	7.5	11	-	-	65	70	70	80
													5	7.6	72	80	78	80
													7.5	11	76	80	81	90
													10	14	80	90	85	90
													-	-	69	80	74	80
													5	7.6	76	90	81	90
											10	14	7.5	11	80	90	85	90
													10	14	83	90	88	100
													-	-	77	90	82	100
													5	7.6	85	100	90	110
													7.5	11	88	100	93	110
													10	14	91	110	96	110
15	21	-	-	85	110	90	110											
		5	7.6	92	110	98	125											
		7.5	11	96	110	101	125											
		10	14	99	125	104	125											
		-	-	85	110	90	110											
		5	7.6	92	110	98	125											
20	27	7.5	11	96	110	101	125											
		10	14	99	125	104	125											
		-	-	85	110	90	110											
		5	7.6	92	110	98	125											
		7.5	11	96	110	101	125											
		10	14	99	125	104	125											
460-3-60	4	10.6	75	16.5	2.15	E4	40	1	46	5.2	7.5	11	-	-	71	80	76	80
													5	7.6	79	90	84	90
													7.5	11	82	90	87	90
													10	14	86	100	91	100
													-	-	75	80	80	90
													5	7.6	83	90	88	100
											10	14	7.5	11	86	100	91	100
													10	14	89	100	94	100
													-	-	84	100	89	110
													5	7.6	91	110	97	110
													7.5	11	95	110	100	110
													10	14	98	110	103	110
15	21	-	-	91	110	96	110											
		5	7.6	99	125	104	125											
		7.5	11	102	125	107	125											
		10	14	105	125	110	125											
		-	-	84	100	89	110											
		5	7.6	91	110	97	110											
20	27	7.5	11	95	110	100	110											
		10	14	98	110	103	110											
		-	-	91	110	96	110											
		5	7.6	99	125	104	125											
		7.5	11	102	125	107	125											
		10	14	105	125	110	125											
460-3-60	4	10.6	75	16.5	2.15	E8	80	2	92	5.2	7.5	11	-	-	106	125	111	125
													5	7.6	113	125	119	125
													7.5	11	117	125	122	125
													10	14	121	125	126	150
													-	-	110	125	115	125
													5	7.6	117	125	122	125
											10	14	7.5	11	121	125	126	150
													10	14	124	125	129	150
													-	-	118	125	123	125
													5	7.6	126	150	131	150
													7.5	11	129	150	134	150
													10	14	132	150	137	150
15	21	-	-	118	125	123	125											
		5	7.6	126	150	131	150											
		7.5	11	129	150	134	150											
		10	14	132	150	137	150											
		-	-	126	150	131	150											
		5	7.6	133	150	139	150											
20	27	7.5	11	137	150	142	150											
		10	14	140	150	145	150											
		-	-	126	150	131	150											
		5	7.6	133	150	139	150											
		7.5	11	137	150	142	150											
		10	14	140	150	145	150											

TABLE 46: ELECTRICAL DATA 25 TON 460 VOLT WITHOUT ERV (CONT.)

Voltage	Compressors (each)				OD Fan Motors (each)	Heat Option				Conv Outlet	Supply Blower Motor		Pwr Exh Motor		W/O Pwr Conv Outlet		With Pwr Conv Outlet			
															MCA <sup>1</sup>	Max Fuse <sup>2</sup> / Breaker <sup>3</sup> Size	MCA <sup>1</sup>	Max Fuse <sup>2</sup> / Breaker <sup>3</sup> Size		
	QTY	RLA	LRA	MCC	FLA	Model	kW	Stages	Amps	FLA	HP	FLA	HP	FLA	Amps	Amps	Amps	Amps		
460-3-60	4	10.6	75	16.5	2.15	E1	108	2	125	5.2	7.5	11	-	-	139	175	144	175		
													5	7.6	146	175	152	175		
													7.5	11	150	175	155	175		
													10	14	154	175	159	175		
											10	14	-	-	143	175	148	175		
													5	7.6	150	175	155	175		
													7.5	11	154	175	159	175		
											10	14	10	14	157	175	162	175		
													15	21	-	-	151	175	156	175
															5	7.6	159	175	164	175
											7.5	11			162	175	167	175		
											10	14	10	14	165	175	170	175		
													20	27	-	-	159	175	164	175
															5	7.6	166	175	172	175
											7.5	11			170	175	175	200		
											10	14	173	200	178	200				

1. Minimum Circuit Ampacity.
2. Dual Element, Time Delay Type.
3. HACR type per NEC.

TABLE 47: ELECTRICAL DATA 25 TON 460 VOLT WITH ERV

Voltage	Compressors (each)				OD Fan Motors (Qty 4)	Heat Option				Conv Outlet	Supply Blower Motor		ERV Wheel Motor		ERV Blower Motor (Qty 2)		W/O Pwr Conv Outlet		With Pwr Conv Outlet	
																	MCA <sup>1</sup>	Max Fuse <sup>2</sup> / Breaker <sup>3</sup> Size	MCA <sup>1</sup>	Max Fuse <sup>2</sup> / Breaker <sup>3</sup> Size
	QTY	RLA	LRA	MCC	FLA	Model	kW	Stages	Amps	FLA	HP	FLA	HP	FLA	HP	FLA	Amps	Amps	Amps	Amps
460-3-60	4	10.6	75	16.5	2.15	None H2O Gas	-	-	-	5.2	7.5	11	0.25	1.2	5	7.6	81	90	86	90
											10	14					85	90	90	100
											15	21					94	110	99	110
											20	27					101	125	106	125
460-3-60	4	10.6	75	16.5	2.15	E4	40	1	46	5.2	7.5	11	0.25	1.2	5	7.6	88	90	93	100
											10	14					91	100	97	110
											15	21					100	110	105	125
											20	27					108	125	113	125
460-3-60	4	10.6	75	16.5	2.15	E8	80	2	92	5.2	7.5	11	0.25	1.2	5	7.6	122	125	127	150
											10	14					126	150	131	150
											15	21					135	150	140	150
											20	27					142	150	147	150
460-3-60	4	10.6	75	16.5	2.15	E1	108	2	125	5.2	7.5	11	0.25	1.2	5	7.6	155	175	160	175
											10	14					159	175	164	175
											15	21					168	175	173	175
											20	27					175	200	180	200

1. Minimum Circuit Ampacity.
2. Dual Element, Time Delay Type.
3. HACR type per NEC.

**TABLE 48: ELECTRICAL DATA 25 TON 575 VOLT WITHOUT ERV**

Volt	Compressors (each)				OD Fan Motors (each)	Heat Option				Conv Outlet	Supply Blower Motor		Pwr Exh Motor	W/O Pwr Conv Outlet		With Pwr Conv Outlet		
														MCA <sup>1</sup>	Max Fuse <sup>2</sup> / Breaker <sup>3</sup> Size	MCA <sup>1</sup>	Max Fuse <sup>2</sup> / Breaker <sup>3</sup> Size	
	QTY	RLA	LRA	MCC	FLA	Model	kW	Stages	Amps	FLA	HP	FLA	HP	FLA	Amps	Amps	Amps	Amps
575-3-60	4	7.7	54	12	1.7	None/Gas	-	-	-	4.2	7.5	9	-	-	49	50	53	60
													5	6.1	55	60	59	60
													7.5	9	58	60	62	70
													10	11	60	70	65	70
													-	-	51	60	56	60
													5	6.1	57	60	62	70
											10	11	7.5	9	60	70	65	70
													10	11	62	70	67	70
													-	-	59	70	63	80
													5	6.1	65	80	69	80
													7.5	9	68	80	72	80
													10	11	70	80	74	90
15	17	-	-	65	80	69	90											
		5	6.1	71	90	75	90											
		7.5	9	74	90	78	100											
		10	11	76	90	80	100											
		-	-	61	70	65	70											
		5	6.1	67	70	72	80											
575-3-60	4	7.7	54	12	1.7	E4	40	1	40	4.2	7.5	9	7.5	9	70	70	74	80
													10	11	73	80	77	80
													-	-	64	70	68	70
													5	6.1	70	80	74	80
													7.5	9	73	80	77	80
													10	11	75	80	79	90
											10	11	-	-	71	80	75	90
													5	6.1	77	90	82	90
													7.5	9	80	90	84	100
													10	11	82	90	86	100
													-	-	78	100	82	100
													5	6.1	84	100	88	110
15	17	7.5	9	87	100	91	110											
		10	11	89	110	93	110											
		-	-	78	100	82	100											
		5	6.1	84	100	88	110											
		7.5	9	87	100	91	110											
		10	11	89	110	93	110											
575-3-60	4	7.7	54	12	1.7	E8	80	2	80	4.2	7.5	9	-	-	91	100	95	100
													5	6.1	97	100	102	110
													7.5	9	100	100	104	110
													10	11	103	110	107	110
													-	-	94	100	98	100
													5	6.1	100	110	104	110
											10	11	7.5	9	103	110	107	110
													10	11	105	110	109	110
													-	-	101	110	105	110
													5	6.1	107	110	112	125
													7.5	9	110	125	114	125
													10	11	112	125	116	125
15	17	-	-	108	125	112	125											
		5	6.1	114	125	118	125											
		7.5	9	117	125	121	125											
		10	11	119	125	123	125											
		-	-	101	110	105	110											
		5	6.1	107	110	112	125											
20	22	7.5	9	110	125	114	125											
		10	11	112	125	116	125											
		-	-	108	125	112	125											
		5	6.1	114	125	118	125											
		7.5	9	117	125	121	125											
		10	11	119	125	123	125											



**TABLE 48: ELECTRICAL DATA 25 TON 575 VOLT WITHOUT ERV (CONT.)**

Volt	Compressors (each)				OD Fan Motors (each)	Heat Option				Conv Outlet	Supply Blower Motor		Pwr Exh Motor		W/O Pwr Conv Outlet		With Pwr Conv Outlet											
															MCA <sup>1</sup>	Max Fuse <sup>2</sup> / Breaker <sup>3</sup> Size	MCA <sup>1</sup>	Max Fuse <sup>2</sup> / Breaker <sup>3</sup> Size										
	QTY	RLA	LRA	MCC	FLA	Model	kW	Stages	Amps	FLA	HP	FLA	HP	FLA	Amps	Amps	Amps	Amps										
575-3-60	4	7.7	54	12	1.7	E1	108	2	108	4.2	7.5	9	-	-	119	150	123	150										
													5	6.1	125	150	130	150										
													7.5	9	128	150	132	150										
													10	11	131	150	135	150										
											10	11	-	-	122	150	126	150										
													5	6.1	128	150	132	150										
													7.5	9	131	150	135	150										
											15	17	10	11	133	150	137	150										
													-	-	129	150	133	150										
													5	6.1	135	150	140	150										
											20	22	7.5	9	138	150	142	150										
													10	11	140	150	144	150										
													-	-	136	150	140	150										
													5	6.1	142	150	146	150										

1. Minimum Circuit Ampacity.
2. Dual Element, Time Delay Type.
3. HACR type per NEC.

**TABLE 49: ELECTRICAL DATA 25 TON 575 VOLT WITH ERV**

Volt	Compressors (each)				OD Fan Motors (Qty 4)	Heat Option				Conv Outlet	Supply Blower Motor		ERV Wheel Motor		ERV Blower Motor (Qty 2)		W/O Pwr Conv Outlet		With Pwr Conv Outlet	
																	MCA <sup>1</sup>	Max Fuse <sup>2</sup> / Breaker <sup>3</sup> Size	MCA <sup>1</sup>	Max Fuse <sup>2</sup> / Breaker <sup>3</sup> Size
	QTY	RLA	LRA	MCC	FLA	Model	kW	Stages	Amps	FLA	HP	FLA	HP	FLA	HP	FLA	Amps	Amps	Amps	Amps
575-3-60	4	7.7	54	12	1.7	None H2O Gas	-	-	-	4.2	7.5	9	0.25	0.95	5	6.1	62	70	66	70
											10	11					65	70	69	80
											15	17					72	80	76	90
											20	22					78	100	82	100
575-3-60	4	7.7	54	12	1.7	E4	40	1	40	4.2	7.5	9	0.25	0.95	5	6.1	74	80	79	80
											10	11					77	80	81	90
											15	17					84	100	89	100
											20	22					91	110	95	110
575-3-60	4	7.7	54	12	1.7	E8	80	2	80	4.2	7.5	9	0.25	0.95	5	6.1	104	110	109	110
											10	11					107	110	111	125
											15	17					114	125	119	125
											20	22					121	125	125	125
575-3-60	4	7.7	54	12	1.7	E1	108	2	108	4.2	7.5	9	0.25	0.95	5	6.1	132	150	137	150
											10	11					135	150	139	150
											15	17					142	150	147	150
											20	22					149	150	153	175

1. Minimum Circuit Ampacity.
2. Dual Element, Time Delay Type.
3. HACR type per NEC.

**TABLE 50: ELECTRICAL DATA 30 TON 208/230 VOLT WITHOUT ERV**

Volt	Compressors (each)				OD Fan Motors (each)	Heat Option				Conv Outlet	Supply Blower Motor		Pwr Exh Motor		W/O Pwr Conv Outlet		With Pwr Conv Outlet	
															MCA <sup>1</sup>	Max Fuse <sup>2</sup> / Breaker <sup>3</sup> Size	MCA <sup>1</sup>	Max Fuse <sup>2</sup> / Breaker <sup>3</sup> Size
	QTY	RLA	LRA	MCC	FLA	Model	kW	Stages	Amps	FLA	HP	FLA	HP	FLA	Amps	Amps	Amps	Amps
208-3-60	4	25	164	39	5.8	None/ Gas	-	-	-	11.5	10	30.8	-	-	162	175	173	200
													7.5	24.2	186	200	197	225
													10	30.8	193	200	204	225
													15	46.2	212	250	223	250
											15	46.2	-	-	181	225	192	225
													7.5	24.2	205	250	217	250
													10	30.8	212	250	223	250
													15	46.2	227	250	239	250
											20	59.4	-	-	197	250	209	250
													7.5	24.2	222	250	233	250
													10	30.8	228	250	240	250
											25	74.8	-	-	217	250	228	300
7.5	24.2	241	300	252	300													
10	30.8	248	300	259	300													
15	46.2	263	300	274	300													
230-3-60	4	25	164	39	5.8	None/ Gas	-	-	-	10.4	10	28	-	-	158	175	169	175
													7.5	22	180	200	191	200
													10	28	186	200	197	225
													15	42	204	225	214	250
											15	42	-	-	176	200	186	225
													7.5	22	198	225	208	250
													10	28	204	225	214	250
													15	42	218	250	228	250
											20	54	-	-	191	225	201	250
													7.5	22	213	250	223	250
													10	28	219	250	229	250
													15	42	233	250	243	250
25	68	-	-	208	250	219	250											
		7.5	22	230	250	241	300											
		10	28	236	300	247	300											
		15	42	250	300	261	300											
208-3-60	4	25	164	39	5.8	E4	30	1	83	11.5	10	30.8	-	-	162	175	173	200
													7.5	24.2	186	200	197	225
													10	30.8	193	200	204	225
													15	46.2	212	250	223	250
											15	46.2	-	-	181	225	192	225
													7.5	24.2	205	250	217	250
													10	30.8	212	250	223	250
													15	46.2	227	250	239	250
											20	59.4	-	-	197	250	209	250
													7.5	24.2	222	250	233	250
													10	30.8	228	250	240	250
											25	74.8	-	-	217	250	228	300
7.5	24.2	241	300	252	300													
10	30.8	248	300	259	300													
15	46.2	263	300	274	300													

TABLE 50: ELECTRICAL DATA 30 TON 208/230 VOLT WITHOUT ERV (CONT.)

Volt	Compressors (each)				OD Fan Motors (each)	Heat Option				Conv Outlet	Supply Blower Motor		Pwr Exh Motor		W/O Pwr Conv Outlet		With Pwr Conv Outlet			
															MCA <sup>1</sup>	Max Fuse <sup>2</sup> / Breaker <sup>3</sup> Size	MCA <sup>1</sup>	Max Fuse <sup>2</sup> / Breaker <sup>3</sup> Size		
	QTY	RLA	LRA	MCC	FLA	Model	kW	Stages	Amps	FLA	HP	FLA	HP	FLA	Amps	Amps	Amps	Amps		
230-3-60	4	25	164	39	5.8	E4	40	1	92	10.4	10	28	-	-	158	175	169	175		
													7.5	22	180	200	191	200		
													10	28	186	200	197	225		
													15	42	204	225	214	250		
													-	-	176	200	186	225		
													15	42	7.5	22	198	225	208	250
															10	28	204	225	214	250
															15	42	218	250	228	250
													20	54	-	-	191	225	201	250
															7.5	22	213	250	223	250
															10	28	219	250	229	250
													25	68	15	42	233	250	243	250
-	-	208	250	219	250															
7.5	22	230	250	241	300															
10	30.8	10	28	236	300	247	300													
		15	42	250	300	261	300													
		-	-	206	225	217	225													
208-3-60	4	25	164	39	5.8	E8	60.1	2	167	11.5	10	30.8	7.5	24.2	230	250	241	250		
													10	30.8	236	250	248	250		
													15	46.2	256	300	267	300		
													15	46.2	-	-	225	250	236	250
															7.5	24.2	249	250	260	300
															10	30.8	256	300	267	300
													20	59.4	15	46.2	271	300	282	300
															-	-	241	300	253	300
															7.5	24.2	265	300	277	300
													25	74.8	10	30.8	272	300	284	300
															15	46.2	287	300	299	350
															-	-	261	300	272	300
230-3-60	4	25	164	39	5.8	E8	80	2	185	10.4	10	28	-	-	220	250	230	250		
													7.5	22	242	250	252	300		
													10	28	248	250	258	300		
													15	42	266	300	276	300		
													-	-	238	250	248	250		
													15	42	7.5	22	260	300	270	300
															10	28	266	300	276	300
															15	42	280	300	290	300
													20	54	-	-	253	300	263	300
															7.5	22	275	300	285	300
															10	28	281	300	291	300
													25	68	15	42	295	300	305	350
-	-	270	300	280	300															
7.5	22	292	350	302	350															
10	28	10	28	298	350	308	350													
		15	42	312	350	322	350													
		-	-	270	300	280	300													

1. Minimum Circuit Ampacity.
2. Dual Element, Time Delay Type.
3. HACR type per NEC.

**TABLE 51: ELECTRICAL DATA 30 TON 208/230 VOLT WITH ERV**

Volt	Compressors (each)				OD Fan Motors (Qty 4)	Heat Option				Conv Outlet	Supply Blower Motor		ERV Wheel Motor		ERV Blower Motor (Qty 2)		W/O Pwr'd Conv Outlet		With Pwr'd Conv Outlet	
																	MCA <sup>1</sup>	Max Fuse <sup>2</sup> / Breaker <sup>3</sup> Size	MCA <sup>1</sup>	Max Fuse <sup>2</sup> / Breaker <sup>3</sup> Size
	QTY	RLA	LRA	MCC	FLA	Model	kW	Stages	Amps	FLA	HP	FLA	HP	FLA	HP	FLA	Amps	Amps	Amps	Amps
208-3-60	4	25	164	39	5.8	None H2O Gas	-	-	-	11.5	10	30.8	0.25	2.5	5	16.7	198	225	209	225
															7.5	24.2	213	225	224	250
															5	16.7	217	250	228	250
															7.5	24.2	232	250	243	250
															5	16.7	233	250	245	300
															7.5	24.2	248	300	260	300
															5	16.7	253	300	264	300
															7.5	24.2	268	300	279	350
230-3-60	4	25	164	39	5.8	None H2O Gas	-	-	-	10.4	10	28	0.25	2.5	5	15.2	191	200	202	225
															7.5	22	205	225	215	225
															5	15.2	209	250	219	250
															7.5	22	222	250	233	250
															5	15.2	224	250	234	250
															7.5	22	237	250	248	300
															5	15.2	241	300	252	300
															7.5	22	255	300	265	300
208-3-60	4	25	164	39	5.8	E4	30	1	83	11.5	10	30.8	0.25	2.5	5	16.7	198	225	209	225
															7.5	24.2	213	225	224	250
															5	16.7	217	250	228	250
															7.5	24.2	232	250	243	250
															5	16.7	233	250	245	300
															7.5	24.2	248	300	260	300
															5	16.7	253	300	264	300
															7.5	24.2	268	300	279	350
230-3-60	4	25	164	39	5.8	E4	40	1	92	10.4	10	28	0.25	2.5	5	15.2	191	200	202	225
															7.5	22	205	225	215	225
															5	15.2	209	250	219	250
															7.5	22	222	250	233	250
															5	15.2	224	250	234	250
															7.5	22	237	250	248	300
															5	15.2	241	300	252	300
															7.5	22	255	300	265	300
208-3-60	4	25	164	39	5.8	E8	60.1	2	167	11.5	10	30.8	0.25	2.5	5	16.7	241	250	253	300
															7.5	24.2	256	300	268	300
															5	16.7	261	300	272	300
															7.5	24.2	276	300	287	300
															5	16.7	277	300	289	300
															7.5	24.2	292	350	304	350
															5	16.7	296	350	308	350
															7.5	24.2	311	350	323	350
230-3-60	4	25	164	39	5.8	E8	80	2	185	10.4	10	28	0.25	2.5	5	15.2	253	300	263	300
															7.5	22	267	300	277	300
															5	15.2	270	300	281	300
															7.5	22	284	300	294	300
															5	15.2	285	300	296	350
															7.5	22	299	350	309	350
															5	15.2	303	350	313	350
															7.5	22	317	350	327	350

1. Minimum Circuit Ampacity.
2. Dual Element, Time Delay Type.
3. HACR type per NEC.

TABLE 52: ELECTRICAL DATA 30 TON 460 VOLT WITHOUT ERV

Volt	Compressors (each)				OD Fan Motors (each)	Heat Option				Conv Outlet	Supply Blower Motor		Pwr Exh Motor	W/O Pwr Conv Outlet		With Pwr Conv Outlet			
														MCA <sup>1</sup>	Max Fuse <sup>2</sup> / Breaker <sup>3</sup> Size	MCA <sup>1</sup>	Max Fuse <sup>2</sup> / Breaker <sup>3</sup> Size		
	QTY	RLA	LRA	MCC	FLA	Model	kW	Stages	Amps	FLA	HP	FLA	HP	FLA	Amps	Amps	Amps	Amps	
460-3-60	4	12.2	100	19	2.9	None/Gas	-	-	-	5.2	10	14	-	-	78	90	83	90	
													7.5	11	89	100	94	100	
													10	14	92	100	97	110	
												15	21	101	110	106	125		
												15	21	-	-	87	100	92	110
														7.5	11	98	110	103	110
											10			14	101	110	106	125	
											20	27	15	21	108	125	113	125	
													-	-	94	110	99	125	
													7.5	11	105	125	110	125	
												10	14	108	125	113	125		
												15	21	115	125	120	125		
25	34	-	-	103	125	108	125												
		7.5	11	114	125	119	150												
		10	14	117	150	122	150												
460-3-60	4	12.2	100	19	2.9	E4	40	1	46	5.2	10	14	-	-	78	90	83	90	
													7.5	11	89	100	94	100	
													10	14	92	100	97	110	
												15	21	101	110	106	125		
												15	21	-	-	87	100	92	110
														7.5	11	98	110	103	110
											10			14	101	110	106	125	
											20	27	15	21	108	125	113	125	
													-	-	94	110	99	125	
													7.5	11	105	125	110	125	
												10	14	108	125	113	125		
												15	21	115	125	120	125		
25	34	-	-	103	125	108	125												
		7.5	11	114	125	119	150												
		10	14	117	150	122	150												
460-3-60	4	12.2	100	19	2.9	E8	80	2	92	5.2	10	14	-	-	110	125	115	125	
													7.5	11	121	125	126	150	
													10	14	124	125	129	150	
												15	21	132	150	137	150		
												15	21	-	-	118	125	123	125
														7.5	11	129	150	134	150
											10			14	132	150	137	150	
											20	27	15	21	139	150	144	150	
													-	-	126	150	131	150	
													7.5	11	137	150	142	150	
												10	14	140	150	145	150		
												15	21	147	150	152	175		
25	34	-	-	135	150	140	150												
		7.5	11	146	175	151	175												
		10	14	149	175	154	175												
15	21	156	175	161	175														

**TABLE 52: ELECTRICAL DATA 30 TON 460 VOLT WITHOUT ERV (CONT.)**

Volt	Compressors (each)				OD Fan Motors (each)	Heat Option				Conv Outlet	Supply Blower Motor		Pwr Exh Motor	W/O Pwr Conv Outlet		With Pwr Conv Outlet				
														MCA <sup>1</sup>	Max Fuse <sup>2</sup> / Breaker <sup>3</sup> Size	MCA <sup>1</sup>	Max Fuse <sup>2</sup> / Breaker <sup>3</sup> Size			
	QTY	RLA	LRA	MCC	FLA	Model	kW	Stages	Amps	FLA	HP	FLA	HP	FLA	Amps	Amps	Amps	Amps		
460-3-60	4	12.2	100	19	2.9	E1	108	2	125	5.2	10	14	-	-	143	175	148	175		
													7.5	11	154	175	159	175		
													10	14	157	175	162	175		
													15	21	165	175	170	175		
											15	21	-	-	151	175	156	175		
													7.5	11	162	175	167	175		
													10	14	165	175	170	175		
											15	21	15	21	172	175	177	200		
													20	27	-	-	159	175	164	175
															7.5	11	170	175	175	200
											10	14			173	200	178	200		
											15	21	15	21	180	200	185	200		
													25	34	-	-	168	200	173	200
															7.5	11	179	200	184	200
											10	14			182	200	187	200		
											15	21	189	200	194	225				

1. Minimum Circuit Ampacity.
2. Dual Element, Time Delay Type.
3. HACR type per NEC.

TABLE 53: ELECTRICAL DATA 30 TON 460 VOLT WITH ERV

Volt	Compressors (each)				OD Fan Motors (Qty 4)	Heat Option				Conv Outlet	Supply Blower Motor		ERV Wheel Motor		ERV Blower Motor (Qty 2)		W/O Pwrd Conv Outlet		With Pwrd Conv Outlet	
																	MCA <sup>1</sup>	Max Fuse <sup>2</sup> / Breaker <sup>3</sup> Size	MCA <sup>1</sup>	Max Fuse <sup>2</sup> / Breaker <sup>3</sup> Size
	QTY	RLA	LRA	MCC	FLA	Model	kW	Stages	Amps	FLA	HP	FLA	HP	FLA	HP	FLA	Amps	Amps	Amps	Amps
460-3-60	4	12.2	100	19	2.9	None H2O Gas	-	-	-	5.2	10	14	0.25	1.2	5	7.6	94	100	100	110
											15	21	0.25	1.2	5	7.6	103	110	108	125
											20	27	0.25	1.2	5	7.6	111	125	116	125
											25	34	0.25	1.2	5	7.6	119	150	125	150
460-3-60	4	12.2	100	19	2.9	E4	40	1	46	5.2	10	14	0.25	1.2	5	7.6	94	100	100	110
											15	21	0.25	1.2	5	7.6	103	110	108	125
											20	27	0.25	1.2	5	7.6	111	125	116	125
											25	34	0.25	1.2	5	7.6	119	150	125	150
460-3-60	4	12.2	100	19	2.9	E8	80	2	92	5.2	10	14	0.25	1.2	5	7.6	126	150	131	150
											15	21	0.25	1.2	5	7.6	135	150	140	150
											20	27	0.25	1.2	5	7.6	142	150	147	150
											25	34	0.25	1.2	5	7.6	151	175	156	175
460-3-60	4	12.2	100	19	2.9	E1	108	2	125	5.2	10	14	0.25	1.2	5	7.6	159	175	164	175
											15	21	0.25	1.2	5	7.6	168	175	173	175
											20	27	0.25	1.2	5	7.6	174	175	180	200
											25	34	0.25	1.2	5	7.6	175	200	180	200

1. Minimum Circuit Ampacity.
2. Dual Element, Time Delay Type.
3. HACR type per NEC.

**TABLE 54: ELECTRICAL DATA 30 TON 575 VOLT WITHOUT ERV**

Volt	Compressors (each)				OD Fan Motors (each)	Heat Option				Conv Outlet	Supply Blower Motor		Pwr Exh Motor	W/O Pwr Conv Outlet		With Pwr Conv Outlet		
														MCA <sup>1</sup>	Max Fuse <sup>2</sup> / Breaker <sup>3</sup> Size	MCA <sup>1</sup>	Max Fuse <sup>2</sup> / Breaker <sup>3</sup> Size	
	QTY	RLA	LRA	MCC	FLA	Model	kW	Stages	Amps	FLA	HP	FLA	HP	FLA	Amps	Amps	Amps	Amps
575-3-60	4	9	78	14	2.2	None/Gas	-	-	-	4.2	10	11	-	-	59	70	63	70
													7.5	9	68	70	72	80
													10	11	70	80	74	80
													15	17	77	90	81	90
											15	17	-	-	66	80	70	80
													7.5	9	75	90	79	90
													10	11	77	90	81	90
													15	17	83	100	87	100
											20	22	-	-	72	90	77	90
													7.5	9	81	100	86	100
													10	11	83	100	88	110
													15	17	89	110	94	110
25	27	-	-	79	100	83	110											
		7.5	9	88	110	92	110											
		10	11	90	110	94	110											
		15	17	96	110	100	125											
575-3-60	4	9	78	14	2.2	E4	40	1	40	4.2	10	11	-	-	64	70	68	70
													7.5	9	73	80	77	80
													10	11	75	80	79	90
													15	17	82	90	86	100
											15	17	-	-	71	80	75	90
													7.5	9	80	90	84	100
													10	11	82	90	86	100
													15	17	88	100	92	100
											20	22	-	-	78	100	82	100
													7.5	9	87	100	91	110
													10	11	89	110	93	110
													15	17	95	110	99	110
25	27	-	-	84	110	88	110											
		7.5	9	93	110	97	110											
		10	11	95	110	99	125											
		15	17	101	125	105	125											
575-3-60	4	9	78	14	2.2	E8	80	2	80	4.2	10	11	-	-	94	100	98	100
													7.5	9	103	110	107	110
													10	11	105	110	109	110
													15	17	112	125	116	125
											15	17	-	-	101	110	105	110
													7.5	9	110	125	114	125
													10	11	112	125	116	125
													15	17	118	125	122	125
											20	22	-	-	108	125	112	125
													7.5	9	117	125	121	125
													10	11	119	125	123	125
													15	17	125	125	129	150
25	27	-	-	114	125	118	125											
		7.5	9	123	150	127	150											
		10	11	125	150	129	150											
		15	17	131	150	135	150											



TABLE 54: ELECTRICAL DATA 30 TON 575 VOLT WITHOUT ERV (CONT.)

Volt	Compressors (each)				OD Fan Motors (each)	Heat Option				Conv Outlet	Supply Blower Motor		Pwr Exh Motor	W/O Pwr Conv Outlet		With Pwr Conv Outlet			
														MCA <sup>1</sup>	Max Fuse <sup>2</sup> / Breaker <sup>3</sup> Size	MCA <sup>1</sup>	Max Fuse <sup>2</sup> / Breaker <sup>3</sup> Size		
	QTY	RLA	LRA	MCC	FLA	Model	kW	Stages	Amps	FLA	HP	FLA	HP	FLA	Amps	Amps	Amps	Amps	
575-3-60	4	9	78	14	2.2	E1	108	2	108	4.2	10	11	-	-	122	150	126	150	
													7.5	9	131	150	135	150	
													10	11	133	150	137	150	
												15	17	140	150	144	150		
												15	17	-	-	129	150	133	150
														7.5	9	138	150	142	150
														10	11	140	150	144	150
												15	17	146	150	150	150		
												20	22	-	-	136	150	140	150
											7.5			9	145	150	149	150	
											10			11	147	150	151	175	
											15	17	153	175	157	175			
											25	27	-	-	142	150	146	150	
													7.5	9	151	175	155	175	
													10	11	153	175	157	175	
15	17	159	175	163	175														

1. Minimum Circuit Ampacity.
2. Dual Element, Time Delay Type.
3. HACR type per NEC.

TABLE 55: ELECTRICAL DATA 30 TON 575 VOLT WITH ERV

Volt	Compressors (each)				OD Fan Motors (Qty 4)	Heat Option				Conv Outlet	Supply Blower Motor		ERV Wheel Motor		ERV Blower Motor (Qty 2)		W/O Pwrd Conv Outlet		With Pwrd Conv Outlet	
																	MCA <sup>1</sup>	Max Fuse <sup>2/</sup> Breaker <sup>3</sup> Size	MCA <sup>1</sup>	Max Fuse <sup>2/</sup> Breaker <sup>3</sup> Size
	QTY	RLA	LRA	MCC	FLA	Model	kW	Stages	Amps	FLA	HP	FLA	HP	FLA	HP	FLA	Amps	Amps	Amps	Amps
575-3-60	4	9	78	14	2.2	None H2O Gas	-	-	-	4.2	10	11	0.25	0.95	5	6.1	72	80	76	80
															7.5	9	78	80	82	90
															5	6.1	79	90	83	100
															7.5	9	85	100	89	100
															5	6.1	85	100	90	110
															7.5	9	91	110	95	110
															5	6.1	92	110	96	110
															7.5	9	98	125	102	125
575-3-60	4	9	78	14	2.2	E4	40	1	40	4.2	10	11	0.25	0.95	5	6.1	77	80	81	90
															7.5	9	83	90	87	90
															5	6.1	84	100	89	100
															7.5	9	90	100	94	110
															5	6.1	91	110	95	110
															7.5	9	96	110	101	110
															5	6.1	97	110	101	125
															7.5	9	103	125	107	125
575-3-60	4	9	78	14	2.2	E8	80	2	80	4.2	10	11	0.25	0.95	5	6.1	107	110	111	125
															7.5	9	113	125	117	125
															5	6.1	114	125	119	125
															7.5	9	120	125	124	125
															5	6.1	121	125	125	125
															7.5	9	126	150	131	150
															5	6.1	127	150	131	150
															7.5	9	133	150	137	150
575-3-60	4	9	78	14	2.2	E1	108	2	108	4.2	10	11	0.25	0.95	5	6.1	135	150	139	150
															7.5	9	141	150	145	150
															5	6.1	142	150	147	150
															7.5	9	148	150	152	175
															5	6.1	149	150	153	175
															7.5	9	154	175	159	175
															5	6.1	155	175	159	175
															7.5	9	161	175	165	175

1. Minimum Circuit Ampacity.
2. Dual Element, Time Delay Type.
3. HACR type per NEC.

**TABLE 56: ELECTRICAL DATA 40 TON 208/230 VOLT WITHOUT ERV**

Volt	Compressors (each)				OD Fan Motors (each)	Heat Option				Conv Outlet	Supply Blower Motor		Pwr Exh Motor		W/O Pwr Conv Outlet		With Pwr Conv Outlet	
															MCA <sup>1</sup>	Max Fuse <sup>2</sup> / Breaker <sup>3</sup> Size	MCA <sup>1</sup>	Max Fuse <sup>2</sup> / Breaker <sup>3</sup> Size
	QTY	RLA	LRA	MCC	FLA	Model	kW	Stages	Amps	FLA	HP	FLA	HP	FLA	Amps	Amps	Amps	Amps
208-3-60	4	28.2	240	44	5.8	None/Gas	-	-	-	11.5	10	30.8	-	-	175	200	186	200
													7.5	24.2	199	225	210	225
													10	30.8	205	225	217	225
													15	46.2	225	250	236	250
											15	46.2	-	-	194	225	205	250
													7.5	24.2	218	250	229	250
													10	30.8	225	250	236	250
													15	46.2	240	250	251	300
											20	59.4	-	-	210	250	222	250
													7.5	24.2	234	250	246	300
													10	30.8	241	300	253	300
													15	46.2	256	300	268	300
25	74.8	-	-	230	300	241	300											
		7.5	24.2	254	300	265	300											
		10	30.8	260	300	272	300											
		15	46.2	276	350	287	350											
230-3-60	4	28.2	240	44	5.8	None/Gas	-	-	-	10.4	10	28	-	-	171	175	181	200
													7.5	22	193	200	203	225
													10	28	199	225	209	225
													15	42	217	250	227	250
											15	42	-	-	189	225	199	225
													7.5	22	211	250	221	250
													10	28	217	250	227	250
													15	42	231	250	241	250
											20	54	-	-	204	250	214	250
													7.5	22	226	250	236	250
													10	28	232	250	242	250
													15	42	246	300	256	300
25	68	-	-	221	250	231	250											
		7.5	22	243	300	253	300											
		10	28	249	300	259	300											
		15	42	263	300	273	300											
208-3-60	4	28.2	240	44	5.8	E4	30	1	83	11.5	10	30.8	-	-	175	200	186	200
													7.5	24.2	199	225	210	225
													10	30.8	205	225	217	225
													15	46.2	225	250	236	250
											15	46.2	-	-	194	225	205	250
													7.5	24.2	218	250	229	250
													10	30.8	225	250	236	250
													15	46.2	240	250	251	300
											20	59.4	-	-	210	250	222	250
													7.5	24.2	234	250	246	300
													10	30.8	241	300	253	300
													15	46.2	256	300	268	300
25	74.8	-	-	230	300	241	300											
		7.5	24.2	254	300	265	300											
		10	30.8	260	300	272	300											
		15	46.2	276	350	287	350											

**TABLE 56: ELECTRICAL DATA 40 TON 208/230 VOLT WITHOUT ERV (CONT.)**

Volt	Compressors (each)				OD Fan Motors (each)	Heat Option				Conv Outlet	Supply Blower Motor		Pwr Exh Motor	W/O Pwr Conv Outlet		With Pwr Conv Outlet				
														MCA <sup>1</sup>	Max Fuse <sup>2</sup> / Breaker <sup>3</sup> Size	MCA <sup>1</sup>	Max Fuse <sup>2</sup> / Breaker <sup>3</sup> Size			
	QTY	RLA	LRA	MCC	FLA	Model	kW	Stages	Amps	FLA	HP	FLA	HP	FLA	Amps	Amps	Amps	Amps		
230-3-60	4	28.2	240	44	5.8	E4	40	1	92	10.4	10	28	-	-	171	175	181	200		
													7.5	22	193	200	203	225		
													10	28	199	225	209	225		
													15	42	217	250	227	250		
													15	42	-	-	189	225	199	225
															7.5	22	211	250	221	250
															10	28	217	250	227	250
													20	54	15	42	231	250	241	250
															-	-	204	250	214	250
															7.5	22	226	250	236	250
													25	68	10	28	232	250	242	250
															15	42	246	300	256	300
-	-	221	250	231	250															
208-3-60	4	28.2	240	44	5.8	E8	60.1	2	167	11.5	10	30.8	-	-	206	225	217	225		
													7.5	24.2	230	250	241	250		
													10	30.8	236	250	248	250		
													15	46.2	256	300	267	300		
													15	46.2	-	-	225	250	236	250
															7.5	24.2	249	250	260	300
															10	30.8	256	300	267	300
													20	59.4	15	46.2	271	300	282	300
															-	-	241	300	253	300
															7.5	24.2	265	300	277	300
													25	74.8	10	30.8	272	300	284	300
															15	46.2	287	300	299	350
-	-	261	300	272	300															
230-3-60	4	28.2	240	44	5.8	E8	80	2	185	10.4	10	28	-	-	220	250	230	250		
													7.5	22	242	250	252	300		
													10	28	248	250	258	300		
													15	42	266	300	276	300		
													15	42	-	-	238	250	248	250
															7.5	22	260	300	270	300
															10	28	266	300	276	300
													20	54	15	42	280	300	290	300
															-	-	253	300	263	300
															7.5	22	275	300	285	300
													25	68	10	28	281	300	291	300
															15	42	295	300	305	350
-	-	270	300	280	300															
25	68	7.5	22	292	350	302	350													
		10	28	298	350	308	350													
		15	42	312	350	322	350													

1. Minimum Circuit Ampacity.
2. Dual Element, Time Delay Type.
3. HACR type per NEC.

TABLE 57: ELECTRICAL DATA 40 TON 230 VOLT WITH ERV

Volt	Compressors (each)				OD Fan Motors (Qty 4)	Heat Option				Conv Outlet	Supply Blower Motor		ERV Wheel Motor		ERV Blower Motor (Qty 2)		W/O Pwr'd Conv Outlet		With Pwr'd Conv Outlet	
																	MCA <sup>1</sup>	Max Fuse <sup>2/</sup> Breaker <sup>3</sup> Size	MCA <sup>1</sup>	Max Fuse <sup>2/</sup> Breaker <sup>3</sup> Size
	QTY	RLA	LRA	MCC	FLA	Model	kW	Stages	Amps	FLA	HP	FLA	HP	FLA	HP	FLA	Amps	Amps	Amps	Amps
208-3-60	4	28.2	240	44	5.8	None H2O Gas	-	-	-	11.5	10	30.8	0.25	2.5	5 16.7	210	225	222	250	
											15	46.2	0.25	2.5	5 16.7	230	250	241	250	
											20	59.4	0.25	2.5	7.5 24.2	245	250	256	300	
											25	74.8	0.25	2.5	5 16.7	246	300	258	300	
230-3-60	4	28.2	240	44	5.8	None H2O Gas	-	-	-	10.4	10	28	0.25	2.5	5 15.2	204	225	214	225	
											15	42	0.25	2.5	7.5 22	218	225	228	250	
											20	54	0.25	2.5	5 15.2	221	250	245	300	
											25	68	0.25	2.5	7.5 22	235	250	260	300	
208-3-60	4	28.2	240	44	5.8	E4	30	1	83	11.5	10	30.8	0.25	2.5	5 16.7	210	225	222	250	
											15	46.2	0.25	2.5	7.5 24.2	225	250	237	300	
											20	59.4	0.25	2.5	5 16.7	230	250	241	300	
											25	74.8	0.25	2.5	7.5 24.2	245	250	256	300	
230-3-60	4	28.2	240	44	5.8	E4	40	1	92	10.4	10	28	0.25	2.5	5 15.2	204	225	214	225	
											15	42	0.25	2.5	7.5 22	218	225	228	250	
											20	54	0.25	2.5	5 15.2	221	250	245	300	
											25	68	0.25	2.5	7.5 22	235	250	260	300	
208-3-60	4	28.2	240	44	5.8	E8	60.1	2	167	11.5	10	30.8	0.25	2.5	5 16.7	241	250	253	300	
											15	46.2	0.25	2.5	7.5 24.2	256	300	268	300	
											20	59.4	0.25	2.5	5 16.7	261	300	272	300	
											25	74.8	0.25	2.5	7.5 24.2	276	300	287	300	
230-3-60	4	28.2	240	44	5.8	E8	80	2	185	10.4	10	28	0.25	2.5	5 15.2	253	300	263	300	
											15	42	0.25	2.5	7.5 22	267	300	277	300	
											20	54	0.25	2.5	5 15.2	270	300	281	300	
											25	68	0.25	2.5	7.5 22	284	300	294	300	

1. Minimum Circuit Ampacity.
2. Dual Element, Time Delay Type.
3. HACR type per NEC.

**TABLE 58: ELECTRICAL DATA 40 TON 460 VOLT WITHOUT ERV**

Volt	Compressors (each)				OD Fan Motors (each)	Heat Option				Conv Outlet	Supply Blower Motor		Pwr Exh Motor		W/O Pwr Conv Outlet		With Pwr Conv Outlet	
															MCA <sup>1</sup>	Max Fuse <sup>2</sup> / Breaker <sup>3</sup> Size	MCA <sup>1</sup>	Max Fuse <sup>2</sup> / Breaker <sup>3</sup> Size
	QTY	RLA	LRA	MCC	FLA	Model	kW	Stages	Amps	FLA	HP	FLA	HP	FLA	Amps	Amps	Amps	Amps
460-3-60	4	14.7	130	23	2.9	None/Gas	-	-	-	5.2	10	14	-	-	88	100	93	100
													7.5	11	99	110	104	110
													10	14	102	110	107	110
													15	21	111	125	116	125
													-	-	97	110	102	110
													7.5	11	108	125	113	125
											15	21	10	14	111	125	116	125
													15	21	118	125	123	125
													-	-	104	125	109	125
													7.5	11	115	125	120	125
													10	14	118	125	123	150
													15	21	125	150	130	150
20	27	-	-	113	125	118	150											
		7.5	11	115	125	120	125											
		10	14	118	125	123	150											
		15	21	125	150	130	150											
		-	-	113	125	118	150											
		7.5	11	124	150	129	150											
25	34	10	14	127	150	132	150											
		15	21	134	150	139	150											
		-	-	113	125	118	150											
		7.5	11	124	150	129	150											
		10	14	127	150	132	150											
		15	21	134	150	139	150											
460-3-60	4	14.7	130	23	2.9	E4	40	1	46	5.2	10	14	-	-	88	100	93	100
													7.5	11	99	110	104	110
													10	14	102	110	107	110
													15	21	111	125	116	125
													-	-	97	110	102	110
													7.5	11	108	125	113	125
											15	21	10	14	111	125	116	125
													15	21	118	125	123	125
													-	-	104	125	109	125
													7.5	11	115	125	120	125
													10	14	118	125	123	150
													15	21	125	150	130	150
20	27	-	-	113	125	118	150											
		7.5	11	115	125	120	125											
		10	14	118	125	123	150											
		15	21	125	150	130	150											
		-	-	113	125	118	150											
		7.5	11	124	150	129	150											
25	34	10	14	127	150	132	150											
		15	21	134	150	139	150											
		-	-	110	125	115	125											
		7.5	11	121	125	126	150											
		10	14	124	125	129	150											
		15	21	132	150	137	150											
460-3-60	4	14.7	130	23	2.9	E8	80	2	92	5.2	10	14	-	-	110	125	115	125
													7.5	11	121	125	126	150
													10	14	124	125	129	150
													15	21	132	150	137	150
													-	-	118	125	123	125
													7.5	11	129	150	134	150
											15	21	10	14	132	150	137	150
													15	21	139	150	144	150
													-	-	126	150	131	150
													7.5	11	137	150	142	150
													10	14	140	150	145	150
													15	21	147	150	152	175
20	27	-	-	135	150	140	150											
		7.5	11	146	175	151	175											
		10	14	149	175	154	175											
		15	21	156	175	161	175											
		-	-	135	150	140	150											
		7.5	11	146	175	151	175											
25	34	10	14	149	175	154	175											
		15	21	156	175	161	175											

**TABLE 58: ELECTRICAL DATA 40 TON 460 VOLT WITHOUT ERV (CONT.)**

Volt	Compressors (each)				OD Fan Motors (each)	Heat Option				Conv Outlet	Supply Blower Motor		Pwr Exh Motor	W/O Pwr Conv Outlet		With Pwr Conv Outlet		
														MCA <sup>1</sup>	Max Fuse <sup>2</sup> / Breaker <sup>3</sup> Size	MCA <sup>1</sup>	Max Fuse <sup>2</sup> / Breaker <sup>3</sup> Size	
	QTY	RLA	LRA	MCC	FLA	Model	kW	Stages	Amps	FLA	HP	FLA	HP	FLA	Amps	Amps	Amps	Amps
460-3-60	4	14.7	130	23	2.9	E1	108	2	125	5.2	10	14	-	-	143	175	148	175
													7.5	11	154	175	159	175
													10	14	157	175	162	175
													15	21	165	175	170	175
											15	21	-	-	151	175	156	175
													7.5	11	162	175	167	175
													10	14	165	175	170	175
													15	21	172	175	177	200
											20	27	-	-	159	175	164	175
													7.5	11	170	175	175	200
													10	14	173	200	178	200
													15	21	180	200	185	200
											25	34	-	-	168	200	173	200
													7.5	11	179	200	184	200
													10	14	182	200	187	200
													15	21	189	200	194	225

- 1. Minimum Circuit Ampacity.
- 2. Dual Element, Time Delay Type.
- 3. HACR type per NEC.

TABLE 59: ELECTRICAL DATA 40 TON 460 VOLT WITH ERV

Volt	Compressors (each)				OD Fan Motors (Qty 4)	Heat Option				Conv Outlet	Supply Blower Motor		ERV Wheel Motor		ERV Blower Motor (Qty 2)		W/O Pwr'd Conv Outlet		With Pwr'd Conv Outlet	
																	MCA <sup>1</sup>	Max Fuse <sup>2/</sup> Breaker <sup>3</sup> Size	MCA <sup>1</sup>	Max Fuse <sup>2/</sup> Breaker <sup>3</sup> Size
	QTY	RLA	LRA	MCC	FLA	Model	kW	Stages	Amps	FLA	HP	FLA	HP	FLA	HP	FLA	Amps	Amps	Amps	Amps
460-3-60	4	14.72	130	23	2.9	None H2O Gas	-	-	-	5.2	10	14	0.25	1.2	5	7.6	105	110	110	110
															7.5	11	111	125	117	125
											15	21	0.25	1.2	5	7.6	113	125	118	125
															7.5	11	120	125	125	125
										20	27	0.25	1.2	5	7.6	121	125	126	150	
														7.5	11	127	150	133	150	
										25	34	0.25	1.2	5	7.6	129	150	135	150	
														7.5	11	136	150	141	175	
460-3-60	4	14.72	130	23	2.9	E4	40	1	46	5.2	10	14	0.25	1.2	5	7.6	105	110	110	110
															7.5	11	111	125	117	125
											15	21	0.25	1.2	5	7.6	113	125	118	125
															7.5	11	120	125	125	125
										20	27	0.25	1.2	5	7.6	121	125	126	150	
														7.5	11	127	150	133	150	
										25	34	0.25	1.2	5	7.6	129	150	135	150	
														7.5	11	136	150	141	175	
460-3-60	4	14.72	130	23	2.9	E8	80	2	92	5.2	10	14	0.25	1.2	5	7.6	126	150	131	150
															7.5	11	133	150	138	150
											15	21	0.25	1.2	5	7.6	135	150	140	150
															7.5	11	141	150	147	150
										20	27	0.25	1.2	5	7.6	142	150	147	150	
														7.5	11	149	175	154	175	
										25	34	0.25	1.2	5	7.6	151	175	156	175	
														7.5	11	158	175	163	175	
460-3-60	4	14.72	130	23	2.9	E1	108	2	125	5.2	10	14	0.25	1.2	5	7.6	159	175	164	175
															7.5	11	166	175	171	175
											15	21	0.25	1.2	5	7.6	168	175	173	175
															7.5	11	174	175	180	200
										20	27	0.25	1.2	5	7.6	175	200	180	200	
														7.5	11	182	200	187	200	
										25	34	0.25	1.2	5	7.6	184	200	189	200	
														7.5	11	191	225	196	225	

1. Minimum Circuit Ampacity.
2. Dual Element, Time Delay Type.
3. HACR type per NEC.



**TABLE 60: ELECTRICAL DATA 40 TON 575 VOLT WITHOUT ERV**

Volt	Compressors (each)				OD Fan Motors (each)	Heat Option				Conv Outlet	Supply Blower Motor		Pwr Exh Motor	W/O Pwr Conv Outlet		With Pwr Conv Outlet		
														MCA <sup>1</sup>	Max Fuse <sup>2</sup> / Breaker <sup>3</sup> Size	MCA <sup>1</sup>	Max Fuse <sup>2</sup> / Breaker <sup>3</sup> Size	
	QTY	RLA	LRA	MCC	FLA	Model	kW	Stages	Amps	FLA	HP	FLA	HP	FLA	Amps	Amps	Amps	Amps
575-3-60	4	11.3	93.7	17.6	2.2	None/Gas	-	-	-	4.2	10	11	-	-	68	70	72	80
													7.5	9	77	80	81	90
													10	11	79	90	83	90
													15	17	86	100	90	100
											15	17	-	-	75	90	79	90
													7.5	9	84	100	88	100
													10	11	86	100	90	100
													15	17	92	100	96	110
											20	22	-	-	82	100	86	100
													7.5	9	91	110	95	110
													10	11	93	110	97	110
													15	17	99	110	103	125
25	27	-	-	88	110	92	110											
		7.5	9	97	110	101	125											
		10	11	99	125	103	125											
		15	17	105	125	109	125											
575-3-60	4	11.3	93.7	17.6	2.2	E4	40	1	40	4.2	10	11	-	-	68	70	72	80
													7.5	9	77	80	81	90
													10	11	79	90	83	90
													15	17	86	100	90	100
											15	17	-	-	75	90	79	90
													7.5	9	84	100	88	100
													10	11	86	100	90	100
													15	17	92	100	96	110
											20	22	-	-	82	100	86	100
													7.5	9	91	110	95	110
													10	11	93	110	97	110
													15	17	99	110	103	125
25	27	-	-	88	110	92	110											
		7.5	9	97	110	101	125											
		10	11	99	125	103	125											
		15	17	105	125	109	125											
575-3-60	4	11.3	93.7	17.6	2.2	E8	80	2	80	4.2	10	11	-	-	94	100	98	100
													7.5	9	103	110	107	110
													10	11	105	110	109	110
													15	17	112	125	116	125
											15	17	-	-	101	110	105	110
													7.5	9	110	125	114	125
													10	11	112	125	116	125
													15	17	118	125	122	125
											20	22	-	-	108	125	112	125
													7.5	9	117	125	121	125
													10	11	119	125	123	125
													15	17	125	125	129	150
25	27	-	-	114	125	118	125											
		7.5	9	123	150	127	150											
		10	11	125	150	129	150											
		15	17	131	150	135	150											

**TABLE 60: ELECTRICAL DATA 40 TON 575 VOLT WITHOUT ERV (CONT.)**

Volt	Compressors (each)				OD Fan Motors (each)	Heat Option				Conv Outlet	Supply Blower Motor		Pwr Exh Motor	W/O Pwr Conv Outlet		With Pwr Conv Outlet												
														MCA <sup>1</sup>	Max Fuse <sup>2</sup> / Breaker <sup>3</sup> Size	MCA <sup>1</sup>	Max Fuse <sup>2</sup> / Breaker <sup>3</sup> Size											
	QTY	RLA	LRA	MCC	FLA	Model	kW	Stages	Amps	FLA	HP	FLA	HP	FLA	Amps	Amps	Amps	Amps										
575-3-60	4	11.3	93.7	17.6	2.2	E1	108	2	108	4.2	10	11	-	-	122	150	126	150										
													7.5	9	131	150	135	150										
													10	11	133	150	137	150										
													15	17	140	150	144	150										
											15	17	-	-	129	150	133	150										
													7.5	9	138	150	142	150										
													10	11	140	150	144	150										
											20	22	15	17	146	150	150	150										
													-	-	136	150	140	150										
													7.5	9	145	150	149	150										
											25	27	10	11	147	150	151	175										
													15	17	153	175	157	175										
													-	-	142	150	146	150										
													7.5	9	151	175	155	175										

1. Minimum Circuit Ampacity.  
 2. Dual Element, Time Delay Type.  
 3. HACR type per NEC.

TABLE 61: ELECTRICAL DATA 40 TON 575 VOLT WITH ERV

Volt	Compressors (each)				OD Fan Motors (Qty 4)	Heat Option				Conv Outlet	Supply Blower Motor		ERV Wheel Motor		ERV Blower Motor (Qty 2)		W/O Pwr Conv Outlet		With Pwr Conv Outlet	
																	MCA <sup>1</sup>	Max Fuse <sup>2</sup> / Breaker <sup>3</sup> Size	MCA <sup>1</sup>	Max Fuse <sup>2</sup> / Breaker <sup>3</sup> Size
	QTY	RLA	LRA	MCC	FLA	Model	kW	Stages	Amps	FLA	HP	FLA	HP	FLA	HP	FLA	Amps	Amps	Amps	Amps
575-3-60	4	11.3	93.7	17.6	2.2	None H2O Gas	-	-	-	4.2	10	11	0.25	0.95	5	6.1	81	90	85	90
															7.5	9	87	90	91	100
															5	6.1	88	100	93	110
															7.5	9	94	110	98	110
															5	6.1	95	110	99	110
															7.5	9	100	110	105	125
															5	6.1	101	125	105	125
															7.5	9	107	125	111	125
575-3-60	4	11.3	93.7	17.6	2.2	E4	40	1	40	4.2	10	11	0.25	0.95	5	6.1	81	90	85	90
															7.5	9	87	90	91	100
															5	6.1	88	100	93	110
															7.5	9	94	110	98	110
															5	6.1	95	110	99	110
															7.5	9	100	110	105	125
															5	6.1	101	125	105	125
															7.5	9	107	125	111	125
575-3-60	4	11.3	93.7	17.6	2.2	E8	80	2	80	4.2	10	11	0.25	0.95	5	6.1	107	110	111	125
															7.5	9	113	125	117	125
															5	6.1	114	125	119	125
															7.5	9	120	125	124	125
															5	6.1	121	125	125	125
															7.5	9	126	150	131	150
															5	6.1	127	150	131	150
															7.5	9	133	150	137	150
575-3-60	4	11.3	93.7	17.6	2.2	E1	108	2	108	4.2	10	11	0.25	0.95	5	6.1	135	150	139	150
															7.5	9	141	150	145	150
															5	6.1	142	150	147	150
															7.5	9	148	150	152	175
															5	6.1	149	150	153	175
															7.5	9	154	175	159	175
															5	6.1	155	175	159	175
															7.5	9	161	175	165	175

1. Minimum Circuit Ampacity.
2. Dual Element, Time Delay Type.
3. HACR type per NEC.

**TABLE 62: UNIT WEIGHTS**

COMPONENT	25 TON	30 TON	40 TON
<b>Basic Unit</b>	4410	4605	4785
<b>Gas Heat</b>			
267 MBH	180	180	180
533 MBH	320	320	320
800 MBH	-	-	450
<b>Electric Heat</b>			
40KW	40	40	40
80KW	105	105	105
108KW	110	110	110
<b>Hot Water Heat</b>			
1 Row Coil	70	70	70
2 Row Coil	85	85	85
<b>Steam Heat</b>			
1 Row Coil	85	85	85
<b>Blower</b>			
Forward Curve Fan (Std Fan)	0	0	0
FC IGV	155	155	175
Air Foil Fan	135	135	155
AF IGV	155	155	180
<b>Motor - Supply Fan</b>			
7.5hp	110	-	-
10hp	145	145	145
15hp	200	200	200
20hp	240	240	240
25hp	-	300	300
<b>Supply Fan Motor VFD</b>	See Table 63		
<b>Refrigeration</b>			
T-Coat Evap.	32	30	40
T-Coat cond.	32	30	40
Hot Gas Bypass	10	10	10
<b>Low Ambient Head Pressure Control</b>			
208-230/380/460	5	5	5
575	25	25	25
<b>Filters</b>			
6" Rigid	70	70	70
<b>Exhaust<sup>1</sup></b>			
<b>Exhaust Type</b>			
Barometric	45	65	65
Modulated	140	275	275
<b>Exhaust Motor</b>			
5hp	80	80	80
7.5hp	110	110	110
10hp	145	145	145
15hp	200	200	200
<b>Exhaust Motor VFD</b>	See Table 64		
<b>Economizer</b>			
Std. Econ.	235	235	235
Econ. w/ERV	50	50	50
<b>Control</b>			
Disconnect	15	15	15
110V outlet	55	55	55
Optilogic	20	20	20
<b>Roof Curb</b>			
Partial Curb	415	415	415

<sup>1</sup> If ERV and Supply Fan VAV are selected, add the weight of an Exhaust VFD, Table 63.

**TABLE 63: SUPPLY FAN MOTOR VFD WEIGHTS**

Supply Fan Motor VFD	230V	460V	575V
<b>W/O Bypass</b>			
7.5hp	60	25	30
10hp	60	25	30
15hp	75	50	60
20hp	75	50	60
25hp	115	50	60
<b>W/Bypass</b>			
7.5hp	155	90	120
10hp	155	90	120
15hp	185	140	155
20hp	185	140	155
25hp	255	140	155

**TABLE 64: EXHAUST FAN MOTOR VFD WEIGHTS**

Exhaust Fan Motor	230V	460V	575V
<b>W/O Bypass</b>			
5hp	15	10	20
7.5hp	50	15	20
10hp	50	15	20
15hp	65	40	50

NOTE: If the Millennium is VAV with ERV, add the weight of an exhaust VFD - it will be in the unit.

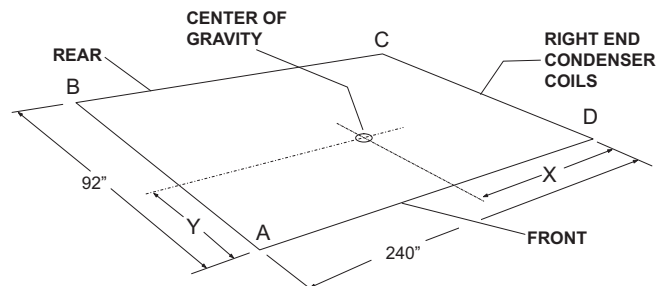

**FIGURE 28 - CENTER OF GRAVITY**

**TABLE 65: UNIT CENTER OF GRAVITY**

MODEL	25 TON		30 TON		40 TON	
	X	Y	X	Y	X	Y
<b>BASIC UNIT</b>	99	48	97	46	98	46
<b>BASIC UNIT / W ECON.</b>	110	48	107	46	102	46
<b>BASIC UNIT / 2 ECON &amp; GAS OR ELECT. HEAT, STEAM OR HOT WATER HEAT</b>	104	48	101	47	101	47
<b>BASIC UNIT / W ECON. &amp; GAS OR ELECT. HEAT, &amp; POWER EXHAUST</b>	118	47	111	47	113	47

**TABLE 66: UNIT CORNERWEIGHT**

UNIT DISCRPTION	25 TON				30 TON				40 TON			
	A	B	C	D	A	B	C	D	A	B	C	D
BASIC UNIT	870	949	1352	1239	932	932	1369	1369	975	975	1418	1418
BASIC UNIT /W ECON.	1018	1111	1313	1203	1078	1084	1337	1338	1064	1064	1446	1446
BASIC UNIT /W ECON. & GAS OR ELECT. HEAT, STEAM OR HOT WATER HEAT	994	1084	1418	1300	1075	1033	1412	1469	1108	1061	1467	1534
BASIC UNIT /W ECON. & GAS OR ELECT. HEAT, & POWER EXHAUST	1220	1275	1318	1262	1277	1235	1419	1476	1341	1284	1449	1515

NOTES: Basic Unit = cooling only, 10hp FC fan.  
+ Econ = +235lb  
+ Heat = single stage gas, 180 lb  
+ Power Exhaust = modulating 7.5hp

**TABLE 67: INDOOR SOUND POWER RATING**

MODEL NUMBER	CFM	ESP	BLOWER		SOUND POWER (dB 10-12 WATTS)								
					OCTAVE BAND CENTERLINE FREQUENCY (Hz)								dba
					63	125	250	500	1000	2000	4000	8000	
Z2	10,000	1.5	RPM	BHP	90	88	85	85	80	78	74	68	87
Z3	12750	1.5	750	7.5	93	91	88	88	83	81	77	71	90
Z5	17500	1.3	840	12.8	95	92	89	89	84	83	78	72	91

Sound Power Ratings for Supply Air Blowers in our Millennium Units with High Gas Heat, Economizer, 2: T/A Filters and Wet DX Sound power calculations complements of Lau's revised "Whirlwind" application selection software for air moving components.

The sound ratings above occur at the blower wheel. To determine the sound rating at a unit's supply and return air duct connection, subtract the attenuation factors listed below.

**TABLE 68: ATTENUATION FACTORS**

LOCATION	OCTAVE BAND CENTERLINE FREQUENCY (Hz)							
	63	125	250	500	1000	2000	4000	8000
	SOUND ATTENUATION (dB <sup>12</sup> WATTS)							
SUPPLY AIR	11	13	18	10	21	21	23	23
RETURN AIR	13	15	22	23	25	25	29	29

**TABLE 69: OUTDOOR SOUND POWER RATING**

MODEL	Octave Band Centerline Frequency (Hertz)								db(A)
	65	125	250	500	1000	2000	4000	8000	
	Sound Power Level, db (10)-12 Watts								
Z2	88	91	89	86	82	79	76	72	88
Z3	87	90	88	86	82	80	77	73	88
Z4	88	91	89	86	82	80	77	73	88

**NOTE:** These values have been accessed using a model of sound propagation from a point source into the hemispheric free field (AMCA 303-79). The dBA values provided are to be used for reference only. Calculation of dBA values cover matters of system design, and the fan manufacturer has no way of

knowing the details of each system. This constitutes an exception to any specification or guarantee requiring a dBA value or sound data in any other form than sound power level ratings.

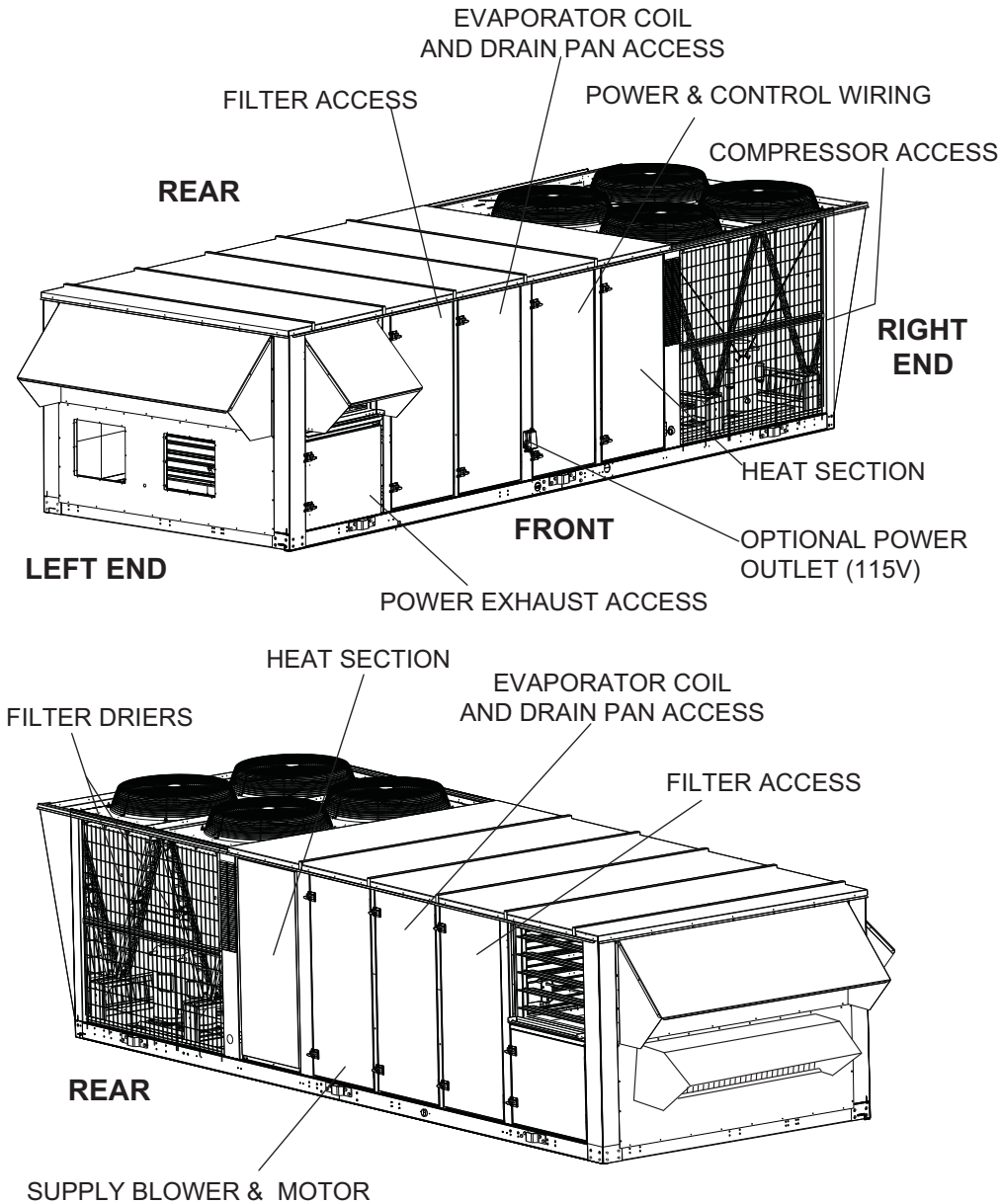

**FIGURE 29 - COMPONENT LOCATION**

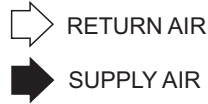

NOTE:  
FACTORY INSTALLED POWER  
EXHAUST CANNOT BE ORDERED  
WITH END RETURN.

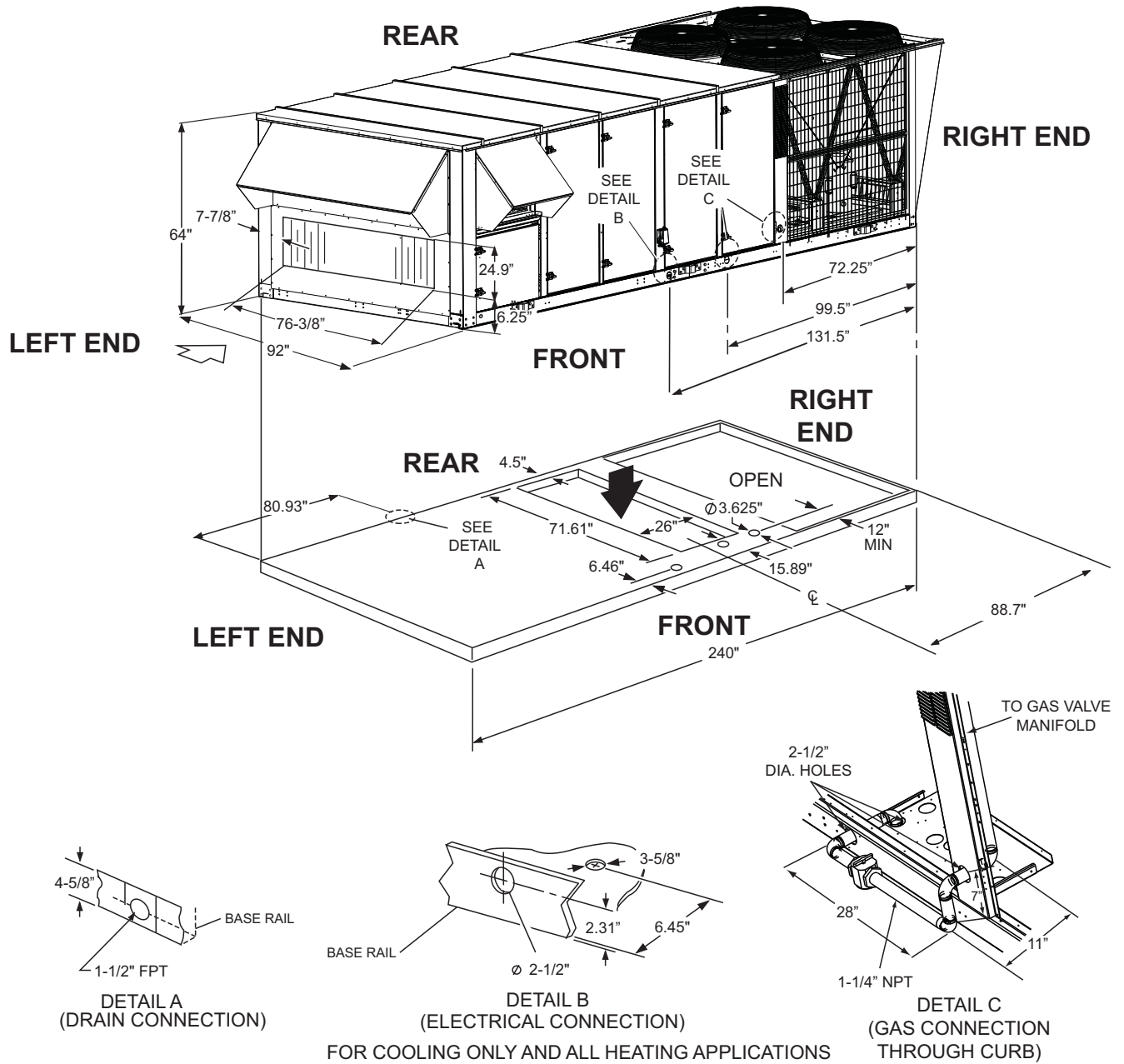

FIGURE 30 - END RETURN, BOTTOM SUPPLY

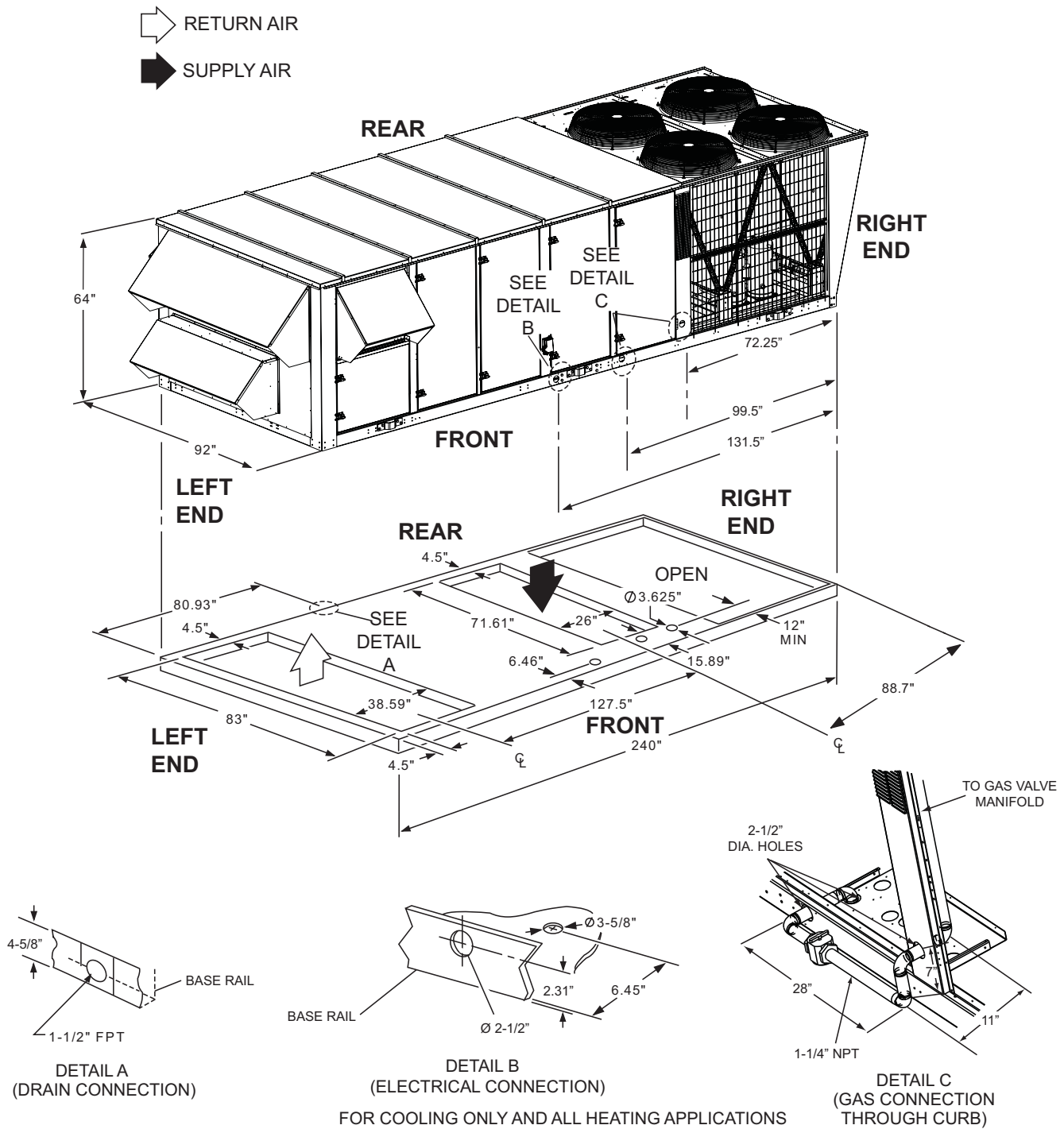
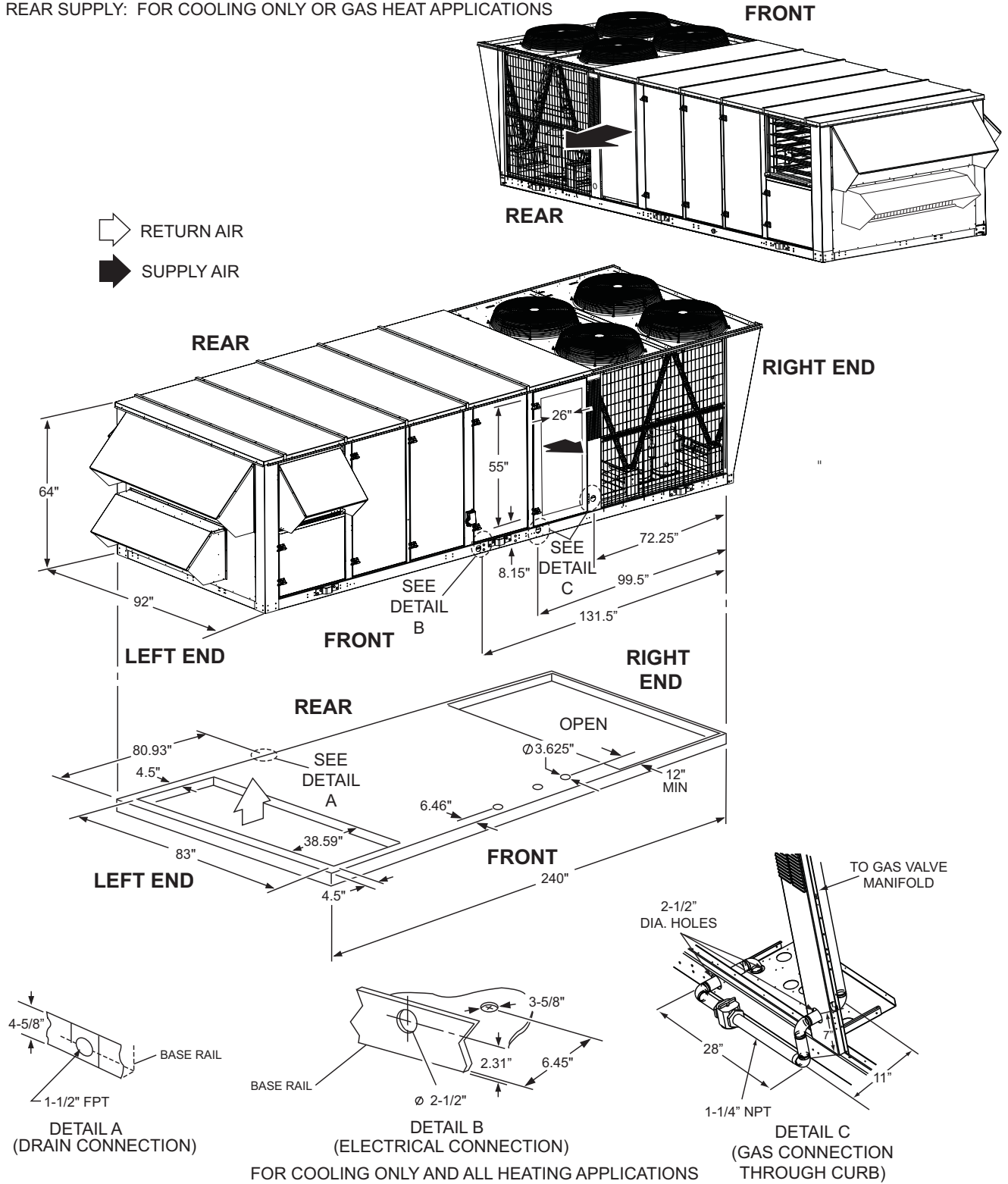

FIGURE 31 - BOTTOM SUPPLY AND RETURN



FRONT SUPPLY: FOR COOLING ONLY APPLICATIONS  
 REAR SUPPLY: FOR COOLING ONLY OR GAS HEAT APPLICATIONS



**FIGURE 32 - BOTTOM RETURN, FRONT & REAR SUPPLY**

FRONT SUPPLY: FOR COOLING ONLY APPLICATIONS  
 REAR SUPPLY: FOR COOLING ONLY OR GAS HEAT APPLICATIONS

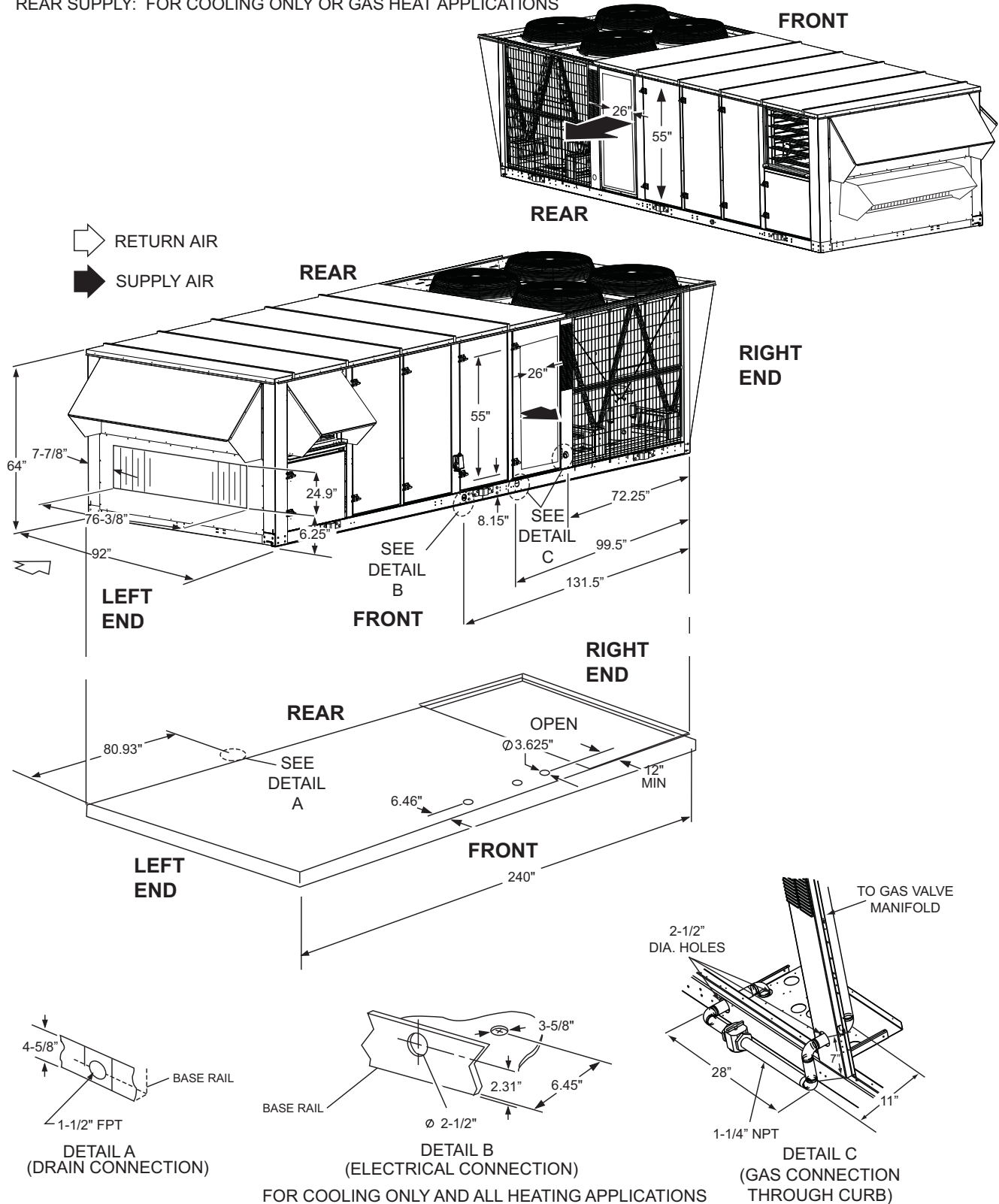
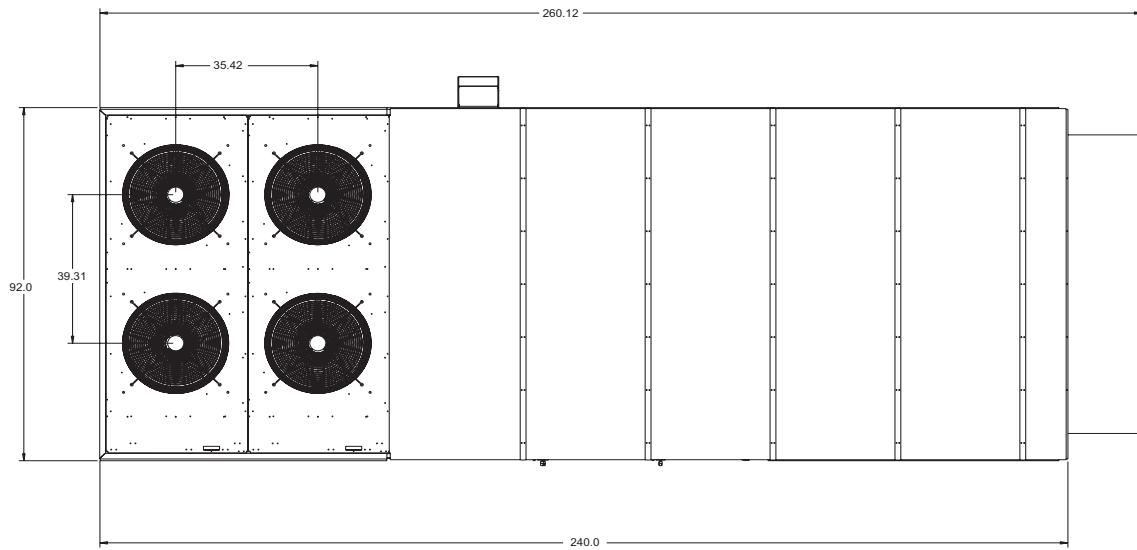
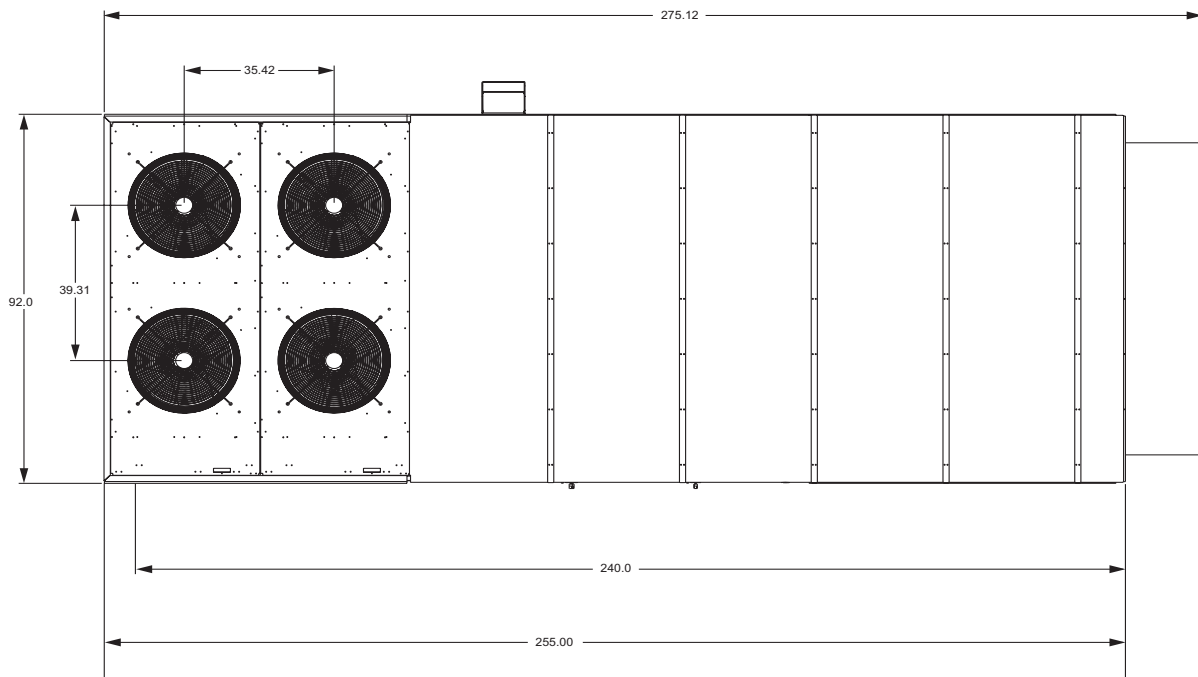

FIGURE 33 - END RETURN, FRONT & REAR SUPPLY

**FIGURE 34 - 25 TON MILLENNIUM OVERHEAD VIEW****FIGURE 35 - 30 AND 40 TON MILLENNIUM OVERHEAD VIEW**

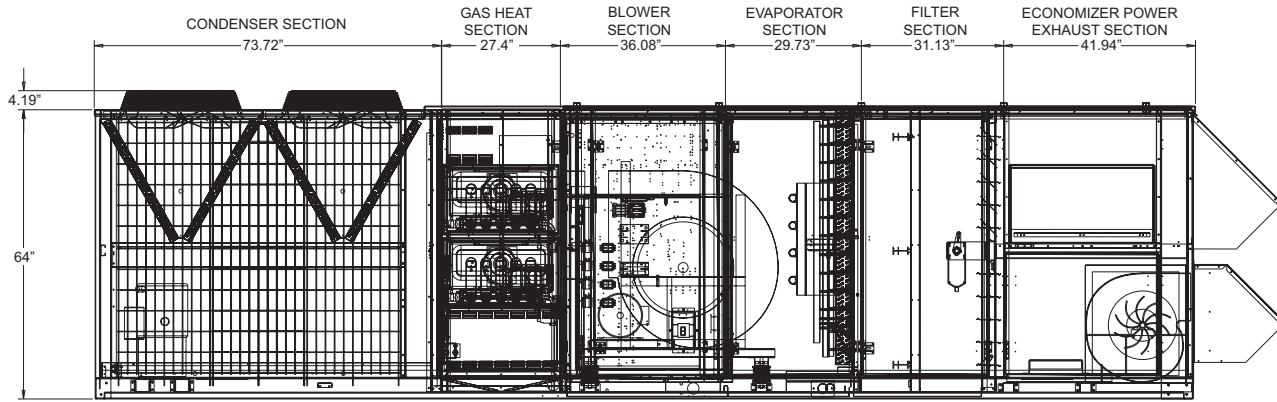

FIGURE 36 - 25 TON MILLENNIUM MAJOR COMPONENT LAYOUT

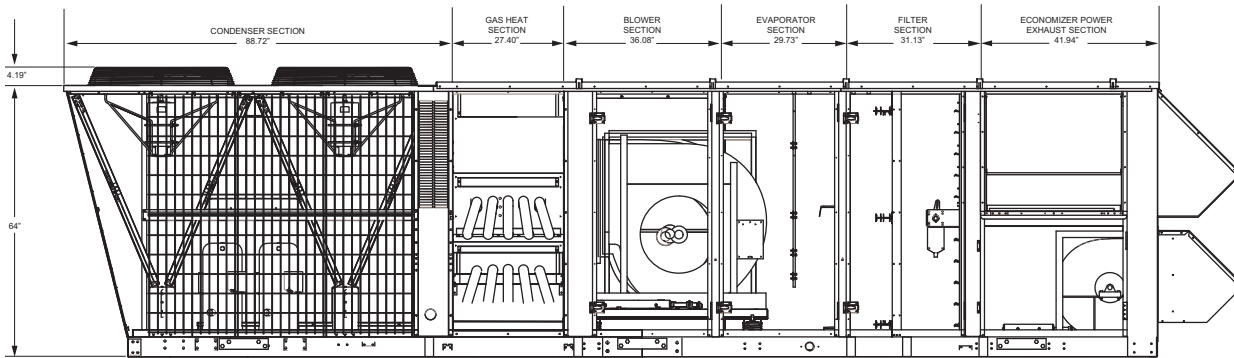
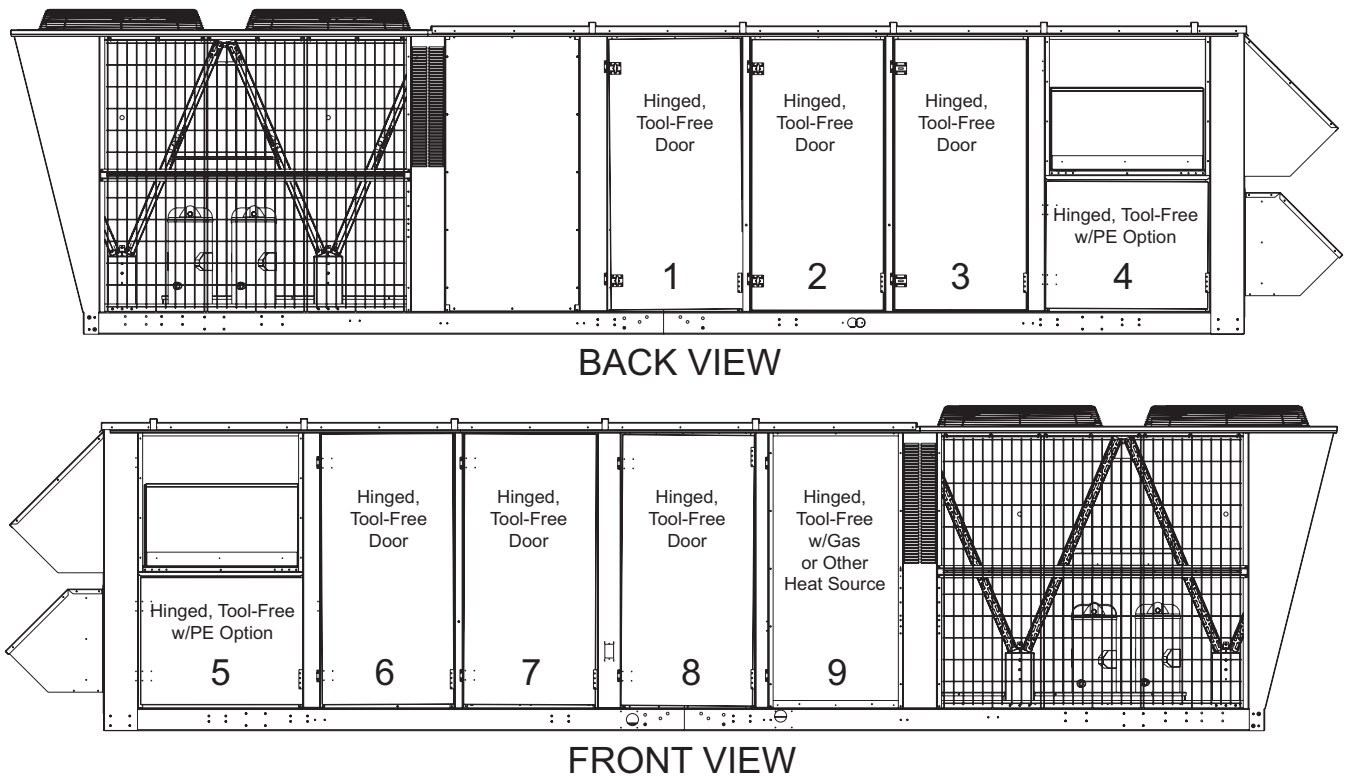

FIGURE 37 - 30 AND 40 TON MILLENNIUM MAJOR COMPONENT LAYOUT



1. STD Cabinet Option includes Hinged, Tool-Free Doors # 1, 3, 6, 8.
2. Premium Cabinet Option includes Hinged, Tool-Free Doors # 1, 2, 3, 6, 7, 8.
3. Doors # 4, 5, 9 are dependent upon unit Heating and Power Exhaust Options.
4. Doors 1, 2, 3, 6, 7, 8 & 9 are 56.31 inches high by 27.33 inches wide.
5. Doors 4 & 5 are 26.5 inches high by 33.63 inches wide.
6. Door configurations are the same on all tonnages (40 ton shown).

**FIGURE 38 - MILLENNIUM CABINET DOOR CONFIGURATION**

REQUIRED CLEARANCES

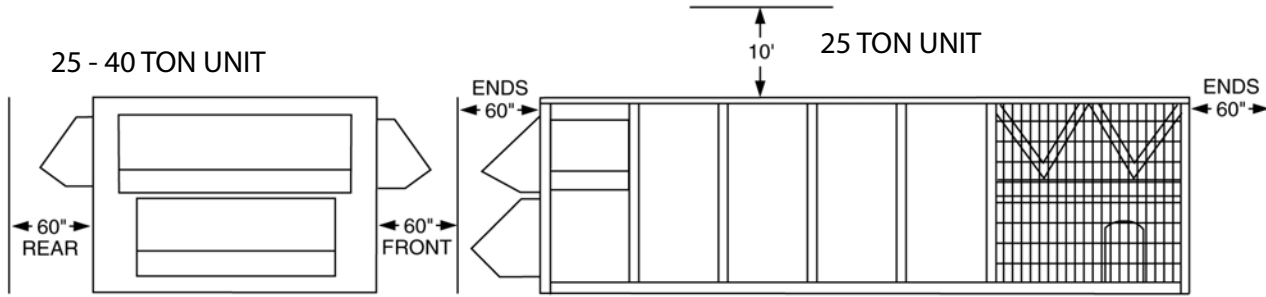

- \* Front is the side with access to the Electrical / Gas Controls.
- \* Right is the side with the Condenser Coils.

LEFT	60"
RIGHT	60"
REAR	60"
FRONT	60"
TOP	10'

**NOTE:** DO NOT use the unit roof to support any type of structure or bracing.

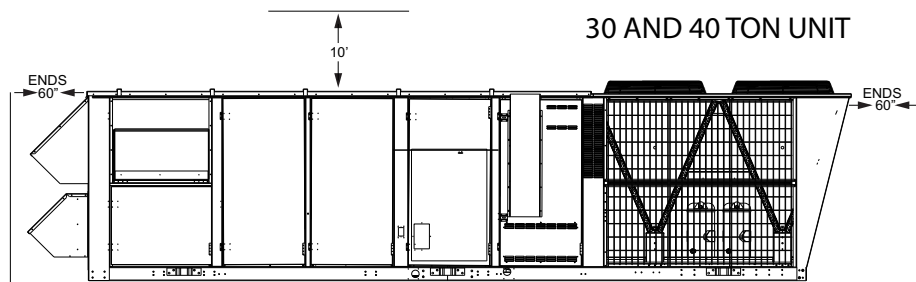

FIGURE 39 - CLEARANCES - HOOD/ECONOMIZER & MOTOR DRIVE - SIDE

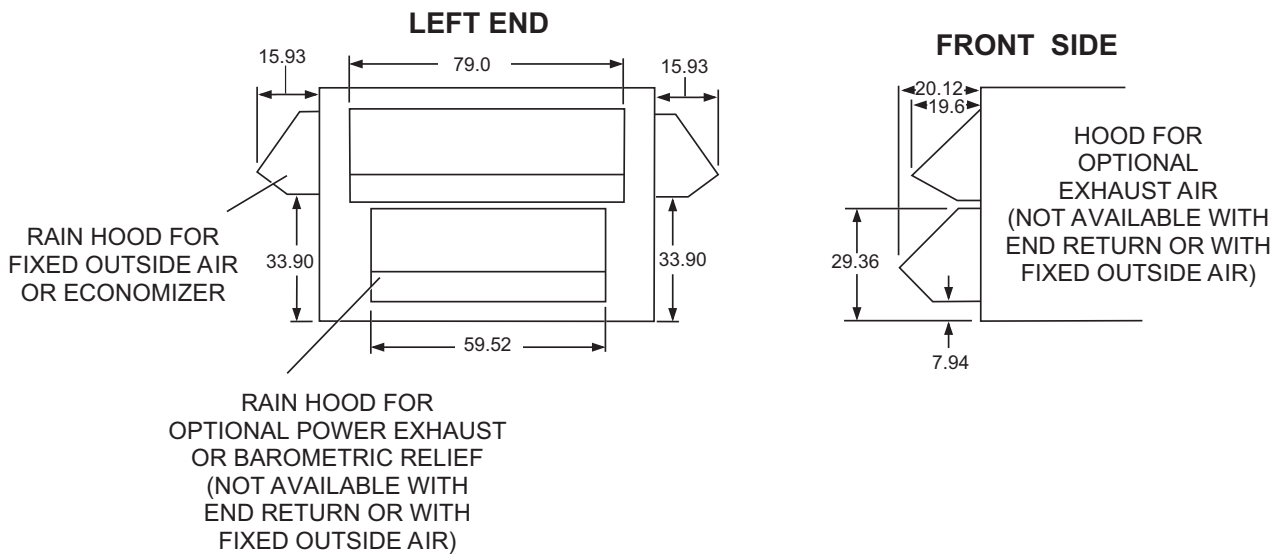

FIGURE 40 - CLEARANCES - HOOD/ECONOMIZER & MOTOR DRIVE - FRONT & END

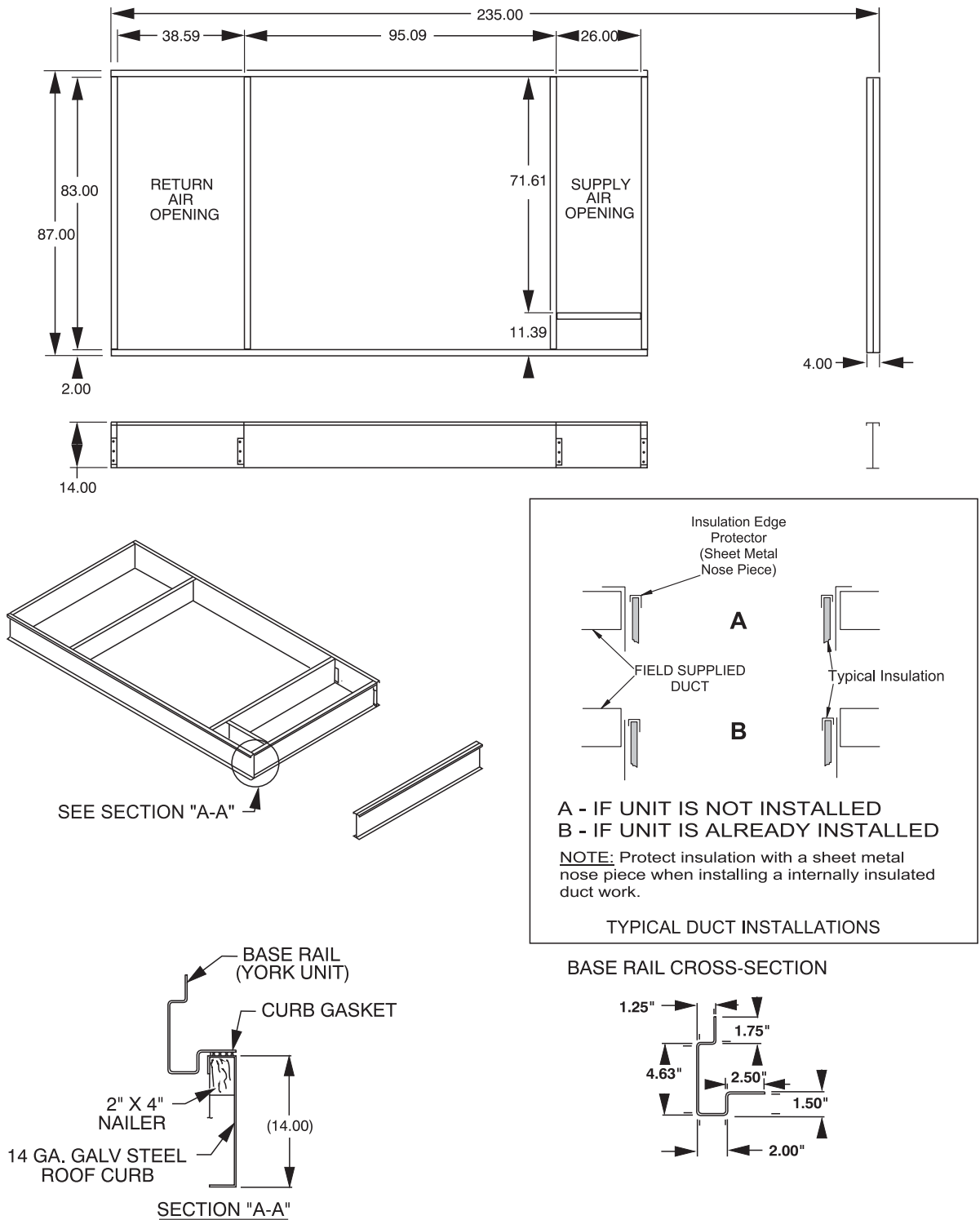

FIGURE 41 - PARTIAL ROOF CURB MODEL 1RC0455P

## GUIDE SPECIFICATIONS - YORK MILLENNIUM 25, 30, & 40 TON UNITS

### GENERAL

Units shall be manufactured by Johnson Controls Ducted Systems in an ISO 9001 certified facility. Introducing the YORK Millennium 25, 30, & 40 ton rooftop line - units designed to provide peak performance and value both today and for years to come. Millennium units are manufactured at an ISO 9001 registered facility, and each rooftop is completely computer-run tested prior to shipment. The Millennium is designed to be flexible enough to meet your needs today and in the future. The true value of York's Millennium is that it can be designed to fit any need, from cooling only, constant volume applications to variable air volume systems with variable frequency drive.

### DESCRIPTION

Supply York Millennium packaged rooftop system in accordance with the capacities in the plans. Units shall be rated by the manufacturer at a minimum 10.5 EER according to AHRI 360. Units shall be shipped in a single package, fully charged with R-410A refrigerant. The manufacturing facility shall be registered under ISO 9001 Quality Standards for Manufacturing. Units shall carry both ETL and CGA safety approval ratings. Tags and decals to aid in the service or indicate caution areas shall be provided. Installation and maintenance manuals shall be supplied with each unit. Units shall be capable of providing mechanical cooling down to 40°F (0°F with low ambient kit). Unit shall be capable of starting and running at 125°F. Unit electric and gas connections shall be either through the curb or the side of the unit.

### CONSTRUCTION

#### Base

The base rail shall be constructed of 12 gauge galvanized steel, extending the full perimeter of the unit. All components shall be supported from the base, and the base shall include integral lifting lugs. The unit base rail shall overhang the roof curb for water runoff and shall have a fabricated recess with a continuous flat surface to seat on the roof curb gasket, providing a positive, weather tight seal between the unit and the curb.

#### Casing

The unit cabinet shall be double wall construction to provide both maximum resistance to bacterial growth in the air stream and superior structural integrity. All sheet metal shall be G90 mill galvanized sheet metal, formed and reinforced to provide a rigid assembly. Sheet metal shall be cleaned in an alkaline and zinc phosphate bath, and the exterior surfaces shall be coated with a 1.5 mil powder paint, capable of withstanding 750 salt spray hours in accordance with ASTM B-117. The

unit shall be insulated with 1-1/2," 1 pound fiberglass insulation between the two sheet metal skins. Insulation shall meet NFPA-90A regulations for smoke and flame spread ratings. The cabinet corner post and the intermediate side supports shall be 16 gauge steel. All access doors shall be 18 gauge on the exterior surfaces, and 20 gauge on the interior. Floor shall be 18 gauge, and 24 gauge. All serviceable sections shall have hinged access doors with latches on both sides of the unit. All access doors shall be constructed of 20 gauge steel on the outside, with 24 gauge on the inside. Each door shall seal against a rubber gasket to prevent air and water leakage. The roof shall be double wall, with 18 gauge on the external surface and 24 gauge on the interior. The roof shall be formed with a 45 degree drip lip overhanging the sidewalls to prevent precipitation drainage from streaming down the side of the unit. Roof sections shall be connected together via integral channels fastened with screws and sealed with rubber gasket. Each fastened seam shall be further protected by a sheet metal channel covering the full length of the gasket surface, making a completely water tight seal.

### SUPPLY AIR SYSTEM

#### SUPPLY AIR FAN

Fans shall be centrifugal type - Class I or Class II or backward inclined airfoil type statically and dynamically balanced in the factory. Fan wheels shall be designed for continuous operation at the maximum rate of fan speed and motor HP. The fan and motor assembly shall be mounted on a common base to allow consistent belt tension with no relative motion between the fan and motor shafts. The entire assembly shall be isolated from the unit base with (optional 1", 2" deflection springs or rubber isolators). The fan discharge shall be connected to the cabinet through a reinforced neoprene flexible connection to eliminate vibration transmission from the fan to the unit casing. Fans shall be double-width, double-inlet with forward curved blades.

#### OPTIONAL

Units equipped with variable frequency drive on supply fan must be controlled either by discrete fan control (IntelliSpeed) driven by compressor staging or by a duct static transducer providing a 2-10 VDC signal to the drive. Supply fan variable frequency drives shall have factory option of being equipped with a manual drive bypass.

### BEARINGS AND DRIVES

Bearings shall be self-aligning pillow-block re-greasable ball bearings with an average life expectancy of 200,000 hours. Grease fittings shall be accessible through access doors. Fan motors shall be NEMA designed, Standard efficiency (option, Hi-efficiency) ball bearing type with electrical characteristics and horsepower as specified. Motors shall be 1750 RPM, open drip proof type. The motor shall be located within the unit on an adjustable, heavy steel base. All fan motor drives



shall be selected for a minimum service factor of 1.2 and have fixed pitched sheaves.

## **AIR FILTERING SYSTEM**

All filter holding frames shall be of heavy duty construction designed for industrial applications. All filters shall be either side accessible or front loading with access doors provided on both sides of the filter section. All filter media shall be Class II listed under UL Standard 900. Filter efficiencies shall be rated in accordance with ASHRAE Standard 52-76 2" Throwaway Filters with fiberglass media multiple shall be standard

### **OPTIONAL**

Two inch pleated, throwaway filters with 30% efficiency. Rigid filters shall be high performance, expanded area, disposable type filters. Rigid filter sections shall be preceded by a 2 throwaway prefilter assembly. Filter efficiency shall be 95% MERV 14 or optional 65% (MERV 8) based on ASHRAE Standard 52-76.

## **AIR INLET SYSTEM**

### **General**

Outside Air inlet openings shall be covered by a factory installed rain hood permanently attached to the cabinet to prevent windblown precipitation from entering the unit. The rain hoods on the front and back of the unit shall be rotated into the cabinet and secured for shipment so that upon installation they need only be rotated upwards and screwed into place. The outside air hood shall contain a removable and cleanable filter with an efficiency rating of 50% based on ASHRAE 52- 76. All damper assemblies shall be of low leak design. Damper blades shall be fabricated from a minimum of 16 gauge galvanized steel. Blade ends and edges shall be covered with vinyl seals. Damper shafts shall be fabricated from solid steel and mounted in the frame with bronze bearings.

### **Economizer (Optional)**

An economizer shall have outdoor air and return air dampers that are interlocked and positioned by fully modulating, solid state damper actuators. The actuators shall be spring loaded so that the outside air damper will close when power to the unit is interrupted. The operation of the economizer shall be fully integrated into the cooling control system. The economizer shall be available for control via a dry bulb sensor (Optional: single or dual enthalpy sensors).

### **RELIEF SYSTEM (Optional)**

All units with relief must have an economizer.

On all units not equipped with an economizer, an option shall be available for a manually adjustable outside air damper that shall be capable of admitting 0-25% outside air.

### **Barometric Relief (Optional)**

Building air exhaust shall be accomplished through barometric relief dampers installed in the return air plenum. The dampers will open relative to the building pressure. The opening pressure shall be adjustable.

### **Exhaust Air Fans (Optional)**

General - forward curved centrifugal fan(s) shall be installed in the return air plenum for positive power exhaust. Fans shall be on a common shaft, driven by a single motor. The fans, motors and drives shall be of the same quality and design as specified for the Supply Air Fan, except the fans shall be Class I. Fans shall be capable of exhausting up to 100% of the nominal CFM of the unit. Non-modulating Exhaust - Units with non-modulating power exhaust shall have a barometric relief damper to prevent outside air from entering in the off cycle. The fans shall cycle on and off with building pressure. Modulating Operation - The fans shall be capable of modulating the amount of air from 0% to 100% of nominal CFM. Modulation shall be through discharge dampers or variable frequency motor speed modulation. Dampers or VFD shall be controlled by static pressure in the conditioned space or return air duct.

## **ENERGY RECOVERY VENTILATION (FIELD INSTALLED OPTION)**

### **General**

The packaged rooftop unit shall have attached at the job site a powered exhaust combined with an air intake through a rotating energy recovery wheel, which captures sensible and latent heat from the exhaust air stream and returns it to the incoming air stream. The energy recovery module will be contained in a separate enclosure designed to attach to the end of the Millennium packaged rooftop unit equipped with Smart Equipment™ control.

The Energy Recovery Ventilation module will be capable of bringing in and exhausting between 8,000 to 13,000 CFM.

Control parameters for the ERV will be preset in the unit control.

## **HEATING SYSTEM**

### **Gas-fired Heating Section (Optional)**

One or more gas-fired heating modules shall be installed to provide the heating requirements per the schedule shown on the plans. The heat exchanger shall be of tubular design. Tubes shall be 2-1/4" OD and constructed of minimum 20 gauge, G160 aluminized steel (1.6 mil aluminum silicone alloy) for corrosion resistance (Optional: 409 Stainless Steel).

Flue baffles shall be made of 430 stainless steel. Each gas-fired heat module shall have an induced draft combustion fan with energy efficient intermittent pilot spark ignition and redundant main gas valves with pressure regulator. Units with standing pilot ignition shall not be acceptable. An induced draft fan shall be provided to maintain a positive flow of air through each tube, to expel the flue gas and to maintain a negative pressure within the heat exchanger relative to the conditioned space. Induced draft fans shall be direct-drive. One (1) high limit controller per heating module, with automatic reset to prevent the heat exchanger from operating at an excessive temperature will be installed. A pressure switch on the combustion section must be provided to prevent ignition until sufficient air flow is established through the heat exchanger. Secondary airflow safety shall be provided by roll-out switch protection. The roll-out switch shall discontinue furnace operation if the flue becomes restricted. Units shall ship with an external flue to be shipped in the unit and mounted on the job site. The flue shall discharge products of combustion above the unit, preventing recycling of corrosive combustion gases back through the heat exchanger. Gas heating sections shall be both ETL and CGA approved to both US and Canadian safety standards.

Optional Modulating Furnace control or Single Stage control available.

### Electric Heating Section

An electric slip-in heater shall be installed within the rooftop unit to provide the heating requirements per the schedule shown on the plans. The electric heater shall be wired in such a manner as to provide two equal steps of capacity (80 and 108 kW) or a single step of capacity (40 kW). The furnace shall be an industrial grade design using an open coil(s) made of the highest grade resistance wire containing 80% nickel and 20% chromium. The resistance coil(s) shall be adequately supported in the air stream using ceramic bushings in the supporting framework. Terminals of the coil(s) shall be stainless steel with high temperature ceramic bushings. The primary high temperature protection shall be an automatic reset type thermal cut out. Secondary protection shall be an automatic reset type thermal cut out. Secondary protection shall be a replaceable thermal link. The operation of the electric heater shall be an integral part of the roof top control system. Power connection to the strip heater shall be through the single power point connection for the entire unit. Electric heat shall be ETL certified to both US and Canadian safety standards.

### Hot Water Heating Coil

The manufacturer shall furnish and factory install a hot water coil in the rooftop units, as described in the following specifications. Water coil capacities and pressure drops shall be certified in accordance with AHRI Standard 410. The hot water coil shall have eight fins per inch, 2 tubes per circuit, and 2" inlet and outlet connection. Primary surface shall be 1/2" OD copper tube, staggered in direction of airflow. Tubes shall be mandrel expanded to form fin bond and provide bur-

nished, work-hardened interior surface. Return bends shall be die formed and silver-brazed to tubes. Headers shall be of heavy seamless copper tubing, silver-brazed to tubes. Connections shall be of red brass, with male pipe threads, silver brazed to headers. Connections also have 1/4" FPT drain plug on each connection. Extended surface shall consist of die-formed, continuous, aluminum fins with formed channels, and surface treatment to minimize moisture carry-over. Fins shall have fully drawn collars to accurately space fins, and to form a protective sheath for the primary surface. A structural galvanized steel casing shall protect the coil. Tube sheets on each end shall have drawn collars to support tubes. An intermediate coil support shall be provided. The coil shall be circuited to provide free draining and venting, through one vent and drain. Completed coil, including headers, connections and return bends shall be tested with 325 pounds compressed air under water. Coils shall be designed for operation at 250 psig design working pressure.

### Steam Heating Coil

The manufacturer shall furnish and factory install a steam heating coil in the rooftop units, as described in the following specifications. Steam coil capacities and pressure drops shall be certified in accordance with AHRI standard 410. The steam coil shall be constructed in the non-freeze style. The steam coil shall have six fins per inch, and 2" inlet, and 1 1/2" outlet connection. Tubes shall be 1" OD seamless copper tubing with a minimum wall thickness of 0.035" and expanded into the fin collars for maximum fin-tube bond. Inner distributing tubes shall be 5/8" OD seamless copper tubing with a minimum wall thickness of 1/4". The copper to copper joints shall be joined with high temperature, silver solder. Corrugated fins with integral spacing collars shall cover the entire tube surface. Headers shall be constructed of seamless copper. The header tube holes shall be extruded providing better tube to header contact for a stronger braze connection. All header connections shall be of red brass or steel, with male pipe threads and silver braze to headers. Casing shall be 16 gauge galvanized steel. Chafing shall be prevented by extruding and flaring the holes in the tube sheet and intermediate tube sheet. The core shall be pitched in the direction of the condensate connection for proper drainage. The completed coil (including headers and connections) shall be tested underwater with 325 lbs. compressed air to ensure a leak free coil.

## REFRIGERATION SYSTEM

Units shall have four independent refrigerant circuits for maximum load-matching capability. Each refrigerant circuit shall be controlled with a balance-port thermal expansion valve for maximum control at low load conditions.

### Evaporator Coils

Evaporator coils shall be direct expansion type with intertwined circuiting to assure complete coil face activity during part load operation. Coil fins shall be enhanced aluminum

type. Coil types shall be 3/8" OD copper, internally enhanced and mechanically expanded to bond with the fins. Coil casing shall be fabricated from heavy gauge galvanized steel. All coils shall be pressure tested at a minimum of 450 PSIG. A galvanized powder painted steel drain pan shall be provided under the entire length and width of the evaporator coil, including all return bends. The main drain pan shall be sloped a total of 1/4" per foot towards the drainage point. Main drain pan shall be easily cleanable in the field. The condensate drain opening shall be flush with the bottom of the drain pan to allow complete drainage. OPTIONAL: Drain pans shall be constructed of stainless steel. OPTIONAL: Evaporator coils shall be protected by the TechniCoat 10-1 four coat process. Coils shall be dipped in a phenolic coating, which provides substantial resistance to corrosion of aluminum and copper. OPTIONAL: Copper-tube/Copper-finned evaporator coil assemblies.

### Compressors

Units shall have four industrial duty hermetic scroll compressors, independently piped and charged. Compressors shall have an enlarged liquid carrying capacity to withstand rugged operating conditions. Compressor frame shall be cast iron, with cast iron fixed and orbiting scrolls. Each compressor shall feature a solid state protection module, designed to protect the compressor from over temperature and over-current conditions. Each compressor shall include the following safety and convenience devices: replaceable suction screen, discharge line check valve, and oil sight glass. Compressors shall be vibration isolated from the unit, and installed in an easily accessible area of the unit.

### Condenser Coils

Condenser coils shall have 3/8" seamless copper tubes, arranged in staggered rows, mechanically expanded into aluminum fins. Coils shall be protected from hail damage with a V configuration, with individual flat coils rotated 30 from the vertical plane for each condensing circuit. Condensing coils shall have an integral subcooler for more efficient, stable operation. OPTIONAL: Condenser coils shall be protected by the TechniCoat 10-1 four coat process. Coils shall be dipped in a phenolic coating, which provides substantial resistance to corrosion of aluminum and copper. OPTIONAL: Copper-tube/Copper-finned condenser coil assemblies.

### Condenser Fans and Motors

Condenser fans shall be direct drive, propeller type, discharging vertically. Condenser fan motors shall be 3 phase, totally enclosed air over (TEAO) type, with built in thermal overload protection.

### Refrigerant Piping

All interconnecting piping between refrigeration components shall be copper tubing with brazed joints. Each refrigerant circuit shall be equipped with liquid line filter drier, and moisture indicating sight glass. Each circuit shall also have both high

and low pressure switches installed on either side of the compressor and include schrader depressors for replacement of the pressure switches without removing charge. All small diameter distributor tubing to the evaporator coil shall be protected by polyurethane sleeves over the length of the tubing to prevent the tubes from copper-to-copper contact during shipment or operation.

### Hot Gas Bypass (Optional on CV; standard on VAV)

Unit shall have hot gas bypass factory installed on the lead compressor.

## CONTROLS

### GENERAL DESCRIPTION

Equipment with Smart Equipment™ as standard shall be factory run-tested through the control, after the test is complete; there will be no wires to re-connect. All control wiring points shall be tested and verified through communication.

The control shall be UL or CSA recognized. The control shall be manufactured in a manufacturing facility that is certified to ISO 9001.

### COMPRESSOR CONTROL

The control shall have a five-minute Anti-Short Cycle Delay to prevent excessive compressor cycling. The control shall have a three-minute minimum run time to insure that oil gets returned to the compressor each time it starts. The minimum runtime shall be programmable up to 10 minutes.

The control shall monitor the High Pressure switch, the Low Pressure switch, and the Compressor Overloads separately for each refrigeration circuit. The control shall have a 30 second Low Pressure Switch bypass when it starts any compressor.

A hard compressor lockout shall occur if the control detects the same switch trip three times in a two-hour window, which starts when the first trip occurs. On the first and second trips, the control will turn the compressor off and wait five-minutes after the switch re-closes, before restarting the compressor.

The control shall be capable of operating all compressors and the economizer when there is a call for multiple of stages of cooling.

The control shall have a means of locking out mechanical compression below a programmable low ambient trip point. This must be done without adding extra components to the unit.

The control shall have a means of locking out the mechanical compression when the economizer is operating in free cooling mode without additional components

The control shall have a means of starting the compressor before the indoor Fan comes on when operating with a Thermostat in the AUTO FAN mode.

## FAN CONTROL

The control shall have fully adjustable Fan ON and Fan OFF delays for both Heating and Cooling settable at the control or via communication.

The control's default Fan OFF delay for Cooling shall be 30 seconds to take advantage of the remaining capacity in the coil after the compressor has been turned off.

The control shall lock on the Fan if the high temperature limit trips three times in one hour of operation.

The control will have a software programmable Fan Mode Switch for Auto operation or Continuous operation.

When the Fan is in the Continuous mode, it will run continuously during the occupied schedule and in the Auto mode when in an unoccupied schedule.

The control shall be capable of operating the fan without a G or fan signal from the thermostat.

## EQUIPMENT CONTROL FEATURES

**Units will come with the new state of the art Smart Equipment™ control system.** The new unit control incorporates the best of the already proven controls and creates a more robust, intelligent control. The goal of this control is to utilize cutting edge technology making the equipment easier to install, operate, and service. All units are Factory commissioned, configured, and run tested.

**Versatile** - The Smart Equipment™ control can be configured to use with a standard thermostat (easy to connect screw terminals), A zone sensor, or can be setup to communicate with multiple BAS communication protocols to integrate with building automation systems.

**Reduce field installed complexity** - Each unit will come equipped with factory installed supply air, return air, and outdoor air temperature sensors providing key temperature readings thus reduce field installed complexity.

**On-board USB Port** - The new control comes with a long list of features including data logging, current and previous system faults and software update capabilities using the on board USB port and common flash drive. Energy use monitoring capabilities allow custom tailoring to allow a system to work more efficiently at all times and occupancy levels. Self test and start-up reports also available from the board VIA the USB port.

**Embedded LCD Display** - The board has a easy to read, built-in LCD display and easy to use navigation joystick and buttons allowing the user to quickly navigate the menus dis-

playing unit status, options, current function, supply, return and outdoor temperatures, fault codes and other information.

**Safety Monitoring** - The control monitors the outdoor, supply, and return air temperatures and the high and low pressure switch status on the independent refrigerant circuits. On units with heating the gas valve and high temperature limit switches are monitored on gas and electric heating units. The control also monitors the voltage supplied to the unit and will protect the unit if low voltage due to a brown out, or other electrical issue occurs.

**Low Ambient** - An integrated low-ambient control allows units to operate in the cooling mode down to 0°F outdoor ambient without additional components or intervention. Optionally, the control board can be programmed to lockout the compressors when the outdoor air temperature is low or when free cooling is available.

**Anti-Short Cycle Protection** - To aid compressor life, an anti-short cycle delay is incorporated into the standard control. Compressor reliability is further ensured by programmable minimum run times. For testing, the anti-short cycle delay can be temporarily overridden with the push of a button.

**Fan Delays** - Fan on and fan off delays are fully programmable. Furthermore, the heating and cooling fan delay times are independent of one another. All units are programmed with default values based upon their configuration of cooling and/or heating capacity.

**Nuisance Trip Protection and Three Strikes** - To prevent nuisance calls, the control board uses a three times, you're out philosophy. The high, low-pressure switch, anti-freeze protection, low voltage or heating high limit must trip three times within two hours before the unit control board will lock out the associated compressor. The same safety must trip three times before a hard lockout will occur.

The control will operate and monitor up to 3 stages of heat independently.

The control shall monitor the Gas Heat operation in the heating mode. It shall monitor the gas valve when there is a call for heating. The control shall alarm when there is a call for heat and no gas valve voltage after 5 minutes.

There will only be one control board for this series of units, for both CV and VAV operation.

## COMFORT CONTROL FEATURES

The control will be installed and tested at the factory where the equipment is assembled.

The control will use a Wall Sensor that has a means of overriding the unoccupied mode for a programmable amount of time.

The Unoccupied Override time will be programmed in minutes up to 4 hours.

The control will use a Wall Sensor that has a warmer/cooler dial so the occupants can offset the programmed setpoint by a programmed amount between 1 and 5 degrees.

The control will have a Supply Air Sensor as standard.

The control will have a Return Air Sensor as standard.

The control will have an Outside Air Sensor as standard.

The control will use the Return Air Sensor in place of the Space Sensor if the Space Sensor fails for any reason, the control will have a 365 day Real Time Clock.

The Real Time Clock will be able to do automatic Daylight Savings Time adjustment.

The control will have an Occupancy Schedule that allows two different Occupied schedules per day for each of the seven days of the week individually.

The control will have 20 Holiday Schedules, each capable of 99 days.

The control's Holiday Schedules will have a start time associated with each schedule.

The control will control the Economizer directly.

The control will be capable of operating the Economizer using Dry Bulb, Outside Enthalpy, or Differential Enthalpy.

When the control is using Enthalpy to control the Economizer, it will also have an Outside Air Temperature enable Setpoint.

The control will use two set points for Supply Air Temperature for the Economizer operation. One will be for a small space cooling demand and one for a large space cooling demand.

The control will have the ability to do Demand Ventilation using one CO<sub>2</sub> sensor.

The control will have a programmable maximum Outside Air Damper Position for IAQ operation.

The control will have the ability to temper the ventilation air during times when heating or cooling is not required.

The control will have the ability to offset the operating setpoint based on high Humidity in the Space.

The control will have programmable limits when offsetting the Operating Setpoint to control Humidity.

The control must be able to lockout Cooling below a programmable Outside Air Temperature Setpoint.

The control will be able to lockout Heating above a programmable Outside Air Temperature Setpoint.

The control will have a Space Temperature Alarm.

The control will have a Supply Air Temperature Alarm for Heating and Cooling. The Alarm temperature will be programmable

The Control will be able to do a Pre-Occupancy Purge at a Programmable Time.

The control will have a hardware Smoke-Purge input.

The control will have the capability of reading a Fan proving switch.

The control will have an intelligent recovery function that will bring the space to the Occupied Setpoint just before or at the beginning of the first Occupied schedule each day. The control will learn and apply the minimum run time required to heat or cool the space to setpoint for the first Occupied period of a day.

The control will have Software controllable Mode Switches (Heat, Cool, and Fan).

The control will meter and track Unoccupied Override Time for billing purposes.

## OPTIONAL CONTROL

### Verasys

Verasys provides a simple user experience with configurable self-recognizing controllers without the need for any additional tools. Verasys creates enhanced integration of HVACR equipment, zoning, and controls. Contractors are able to offer a complete bundled solution of equipment and controls to serve the light commercial market.

### FDD (Fault Detection and Diagnostics) - Refrigerant side

A factory installed control system option on the commercial equipment that constantly monitors refrigerant circuit pressures, refrigerant circuit temperatures, as well as the environmental temperatures and humidity via multiple sensor inputs.

- 
- Provides a building owner, technician or contractor with the operational characteristics of the RTUs entire refrigerant circuit to ensure the unit is functioning at its specified performance level.
  - Provides alarms if the unit is not functioning optimally.
  - Remotely accessible via the Mobile Access Portal (MAP) gateway as well as scrolled on the UCB LCD screen.

## AVAILABLE ACCESSORIES

The following accessories shall be available:

### Partial perimeter roof curbs

14" high roof curb with wood nailer. The partial perimeter roof curb surrounds the portion of the unit which has airflow, and includes a support at the compressor end of the unit.

### Burglar Bars

This accessory mounts in the supply and return opening of the partial perimeter curb to prevent entry into the building through the ductwork.

### Field Installed Barometric Relief

This accessory is a set of barometric relief dampers and hood used for the millennium barometric relief option that is fully

assembled for mounting to return ductwork. This accessory is intended for use on horizontal return applications.

### Programmable thermostat, with or without remote sensor (required for constant volume units)

Provides 2 Heat/4 Cool control and 7 day programming.

### Remote Wall Mounted Temperature Sensors

Attractive wall mounted temperature sensors are available to precisely control multiple or individual zone temperature. Sensors are available without adjustment, with override and override with programmable setpoint adjustment.

### Propane conversion kits

Contains the necessary orifices and gas valve parts to convert from natural gas to propane. Propane cannot be used on modulating gas heat units.

### High altitude conversion kits

These kits are required for natural gas applications between 2,000 and 6,000 feet.

### Energy Recovery Ventilators

8,000 and 13,000 CFM models available. Great applications involving 30% or more of required outdoor air where energy use and comfort must be optimized.